

**FIGURE 1-1A. CAB
Operator Station
S/N 760355 & Above**

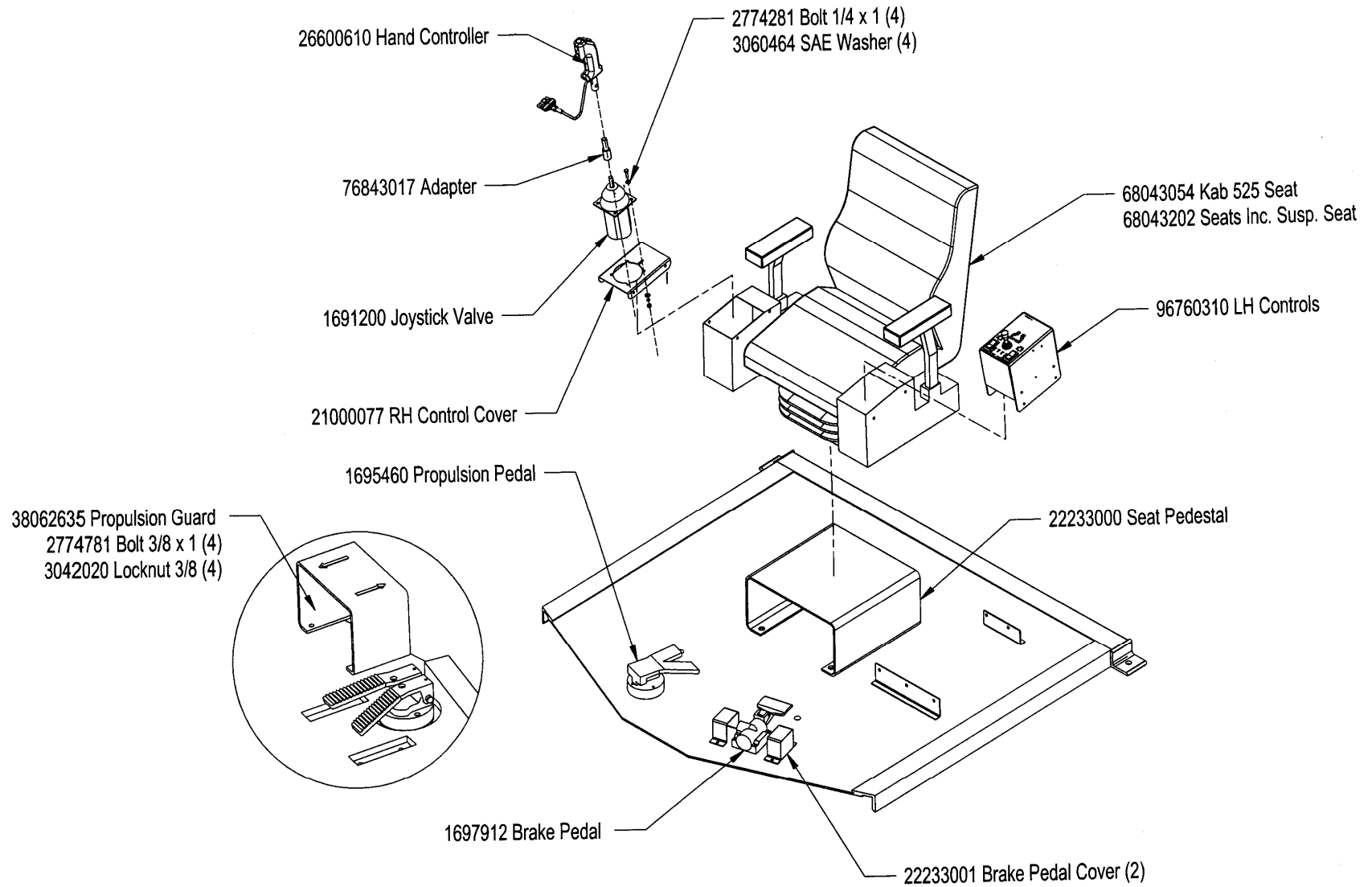

FIGURE 1-2. CAB Cab Accessories

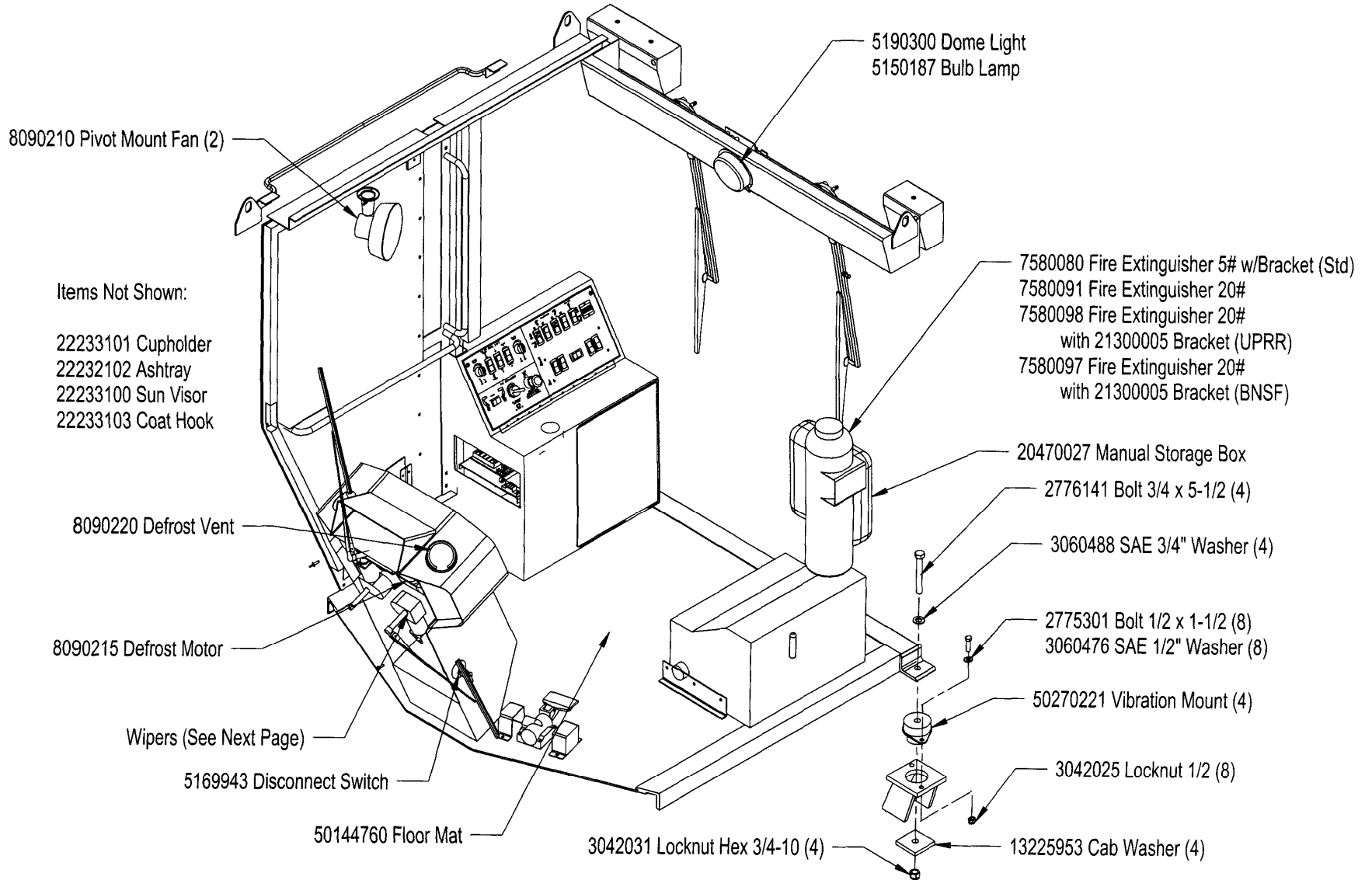

FIGURE 1-4. OPERATOR STATION
Cab Doors and Windows
S/N 760163 and Above

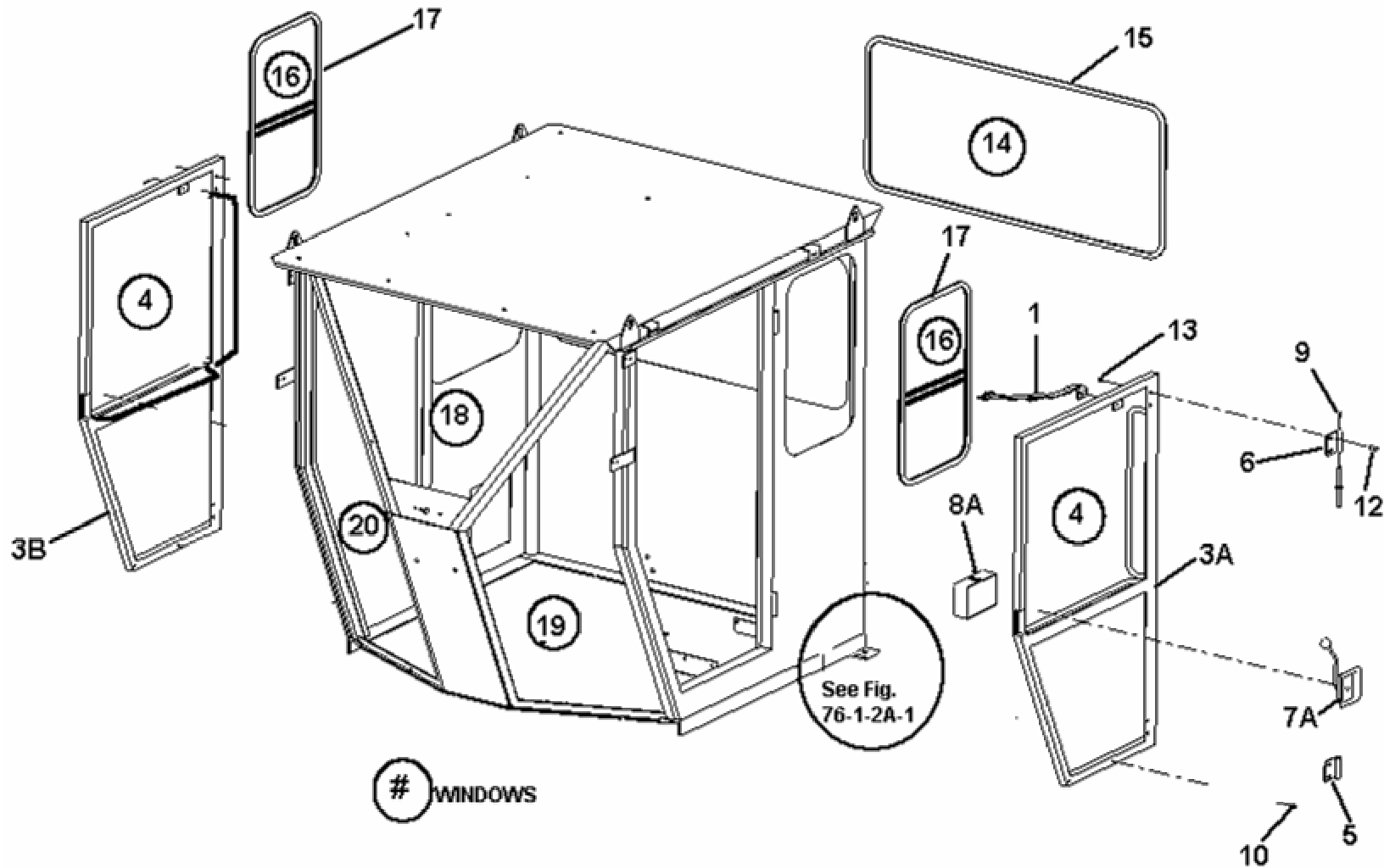



FIGURE 1-4. OPERATOR STATION Cab Doors and Windows S/N 760163 and Above

ITEM NO.	NO.	DESCRIPTION	MACHINE	PART	UNITS PER
1A	8009 130	. HOLDER, Door (Left Door)	1		
1A	8009 131	. HOLDER, Door (Right Door).....	1		
3A	2223 1050	. DOOR, Cab (Left)	1		
3B	2223 1060	. DOOR, Cab (Right).....	1		
4	2223 0011	. WINDOW, Cab Door.....	1		
5	2223 1001	. HINGE, Door Lower Left/Upper Right.....	1		
6	2223 1002	. HINGE, Door Upper Left/Lower Right.....	1		
7A	2223 1003	. HANDLE, Paddle (Left).....	1		
7B	2223 1009	. HANDLE, Paddle (Right)	1		
8A	2223 1006	. COVER, Door Latch (Left)	1		
8B	2223 1011	. COVER, Door Latch (Right).....	1		
9	3801 052	. FITTING, Grease	4		
10	3152 200	. RIVET, Plastic.....	1		
11A	2223 1004	. LATCH, Door (Left)	1		
11B	2223 1010	. LATCH, Door (Right).....	1		
12	2774 781	. CAPSCREW, Hex Head 3/8 x 1	1		
13	3042 019	. LOCKNUT, Hex 3/8-16	1		
14	2223 0003	. WINDOW, Rear Cab.....	1		
15	2223 0010	. GASKET, Rear CabWindow	1		
16	2223 0012	. WINDOW, Side (Adjustable).....	2		
17	2223 0018	. GASKET, Side Window	1		
18	2223 0007	. WINDOW, Front Center Window	1		
19	2223 0008	. WINDOW, Left Hand Front	1		
20	2223 0006	. WINDOW, Right Hand Front.....	1		
26	3060 031	. WASHER, Wrought 3/8.....	1		
27	3064 470	. LOCKWASHER, 3/8	1		
28	2774 776	. CAPSCREW, Hex Head 3/8 x 7/8	1		
31*	2223 1005	. STRIKER, Door Latch.....	1		
32*	2223 1007	. BRACKET, Padlock (Door Side).....	2		
33*	2223 1008	. BRACKET, Padlock (Cab Side).....	2		

**FIGURE 1-4-1. OPERATOR STATION
Cab Doors and Windows Security (Option)
S/N 760163 and Above**



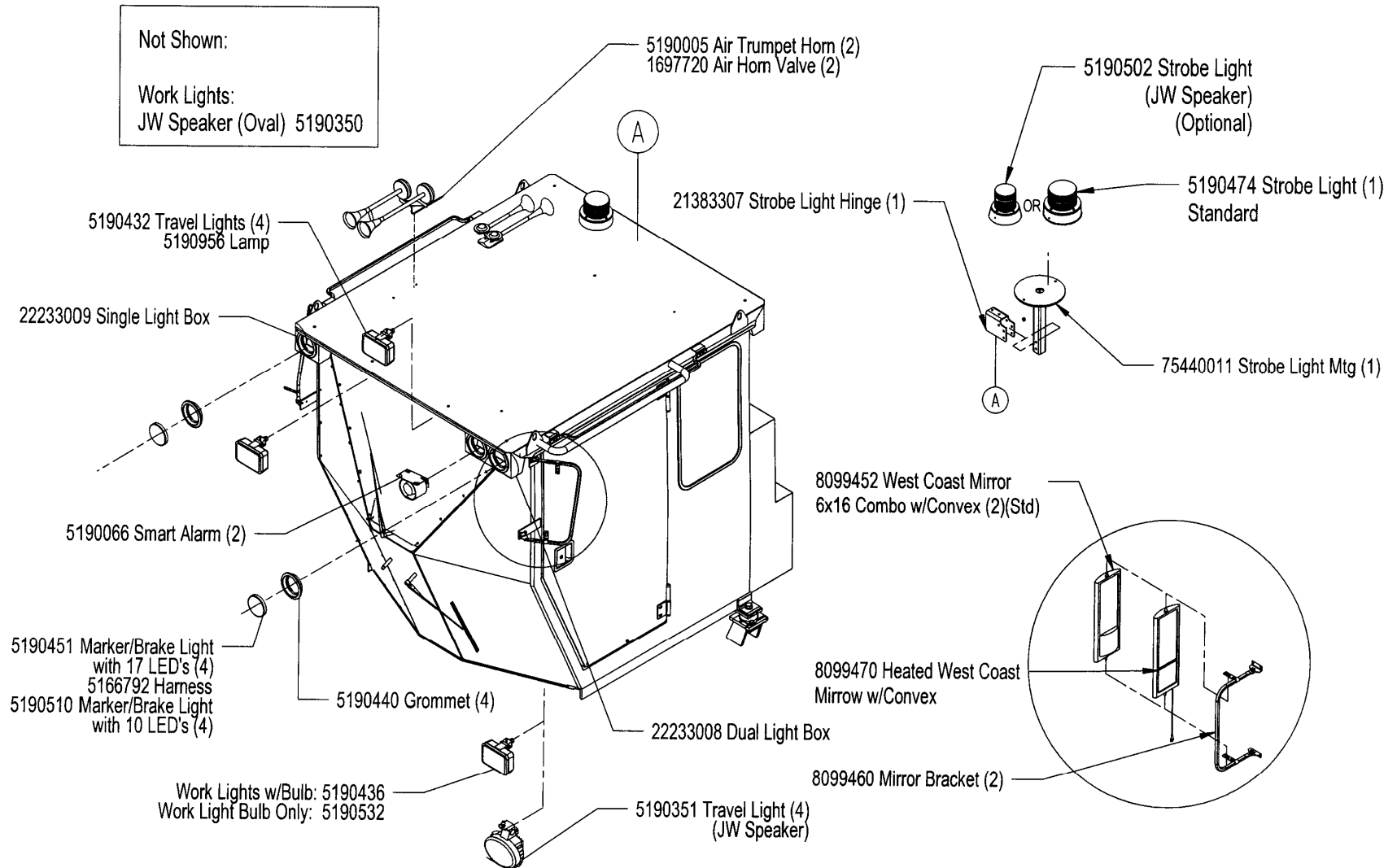

FIGURE 1-4-1. OPERATOR STATION Cab Doors and Windows Security (Option) S/N 760163 and Above

ITEM NO.	NO.	DESCRIPTION	MACHINE
1		LOWER FRONT WINDOW.....	2
	6703 1161	RH SCREEN.....	1
	2100 0165	RH HINGE BRACKET	1
	6703 1160	LH SCREEN	1
	2100 0164	LH HINGE BRACKET	1
	1322 0793	HINGE BAR	2
	2100 0163	LOCK BRACKET	2
2		UPPER FRONT WINDOW	2
	6703 1163	RH SCREEN.....	1
	2100 0160	RH HINGE BRACKET	1
	6703 1162	LH SCREEN	1
	2100 0159	LH HINGE BRACKET	1
	1322 0793	CENTER SCREEN HINGE BRACKET.....	1
	2100 0158	LOCK BRACKET	2
	1317 2357	LOCK BAR.....	2
3		DOORS.....	2
	6703 1169	RH SCREEN.....	1
	2100 0162	RH HINGE BRACKET	1
	6703 1168	LH SCREEN	1
	2100 0161	LH HINGE BRACKET	1
	1322 0703	HINGE BAR	2
	1317 2357	LOCK BAR.....	2
4		SIDE WINDOWS	2
	6703 1170	SCREEN (Either Side).....	2
	1224 5230	ANGLE, SCREEN LOCK.....	2
	1317 1690	RETAINER BAR	2
	1317 1692	LOCK BAR.....	2
	1322 0596	HINGE BAR	4

ITEM NO.	NO.	PART DESCRIPTION	UNITS PER MACHINE
5		REAR WINDOW.....	2
	6703 1165	RH SCREEN	1
	2100 0160	RH HINGE BRACKET	1
	6703 1164	LH SCREEN	1
	2100 0159	LH HINGE BRACKET.....	1
	2100 0158	CENTER BRACKET.....	1
	1322 0812	LOCK BAR	2
6*	2223 3015	PANEL, Electrical Connections	1

FIGURE 1-5A. CAB Lights and Horns



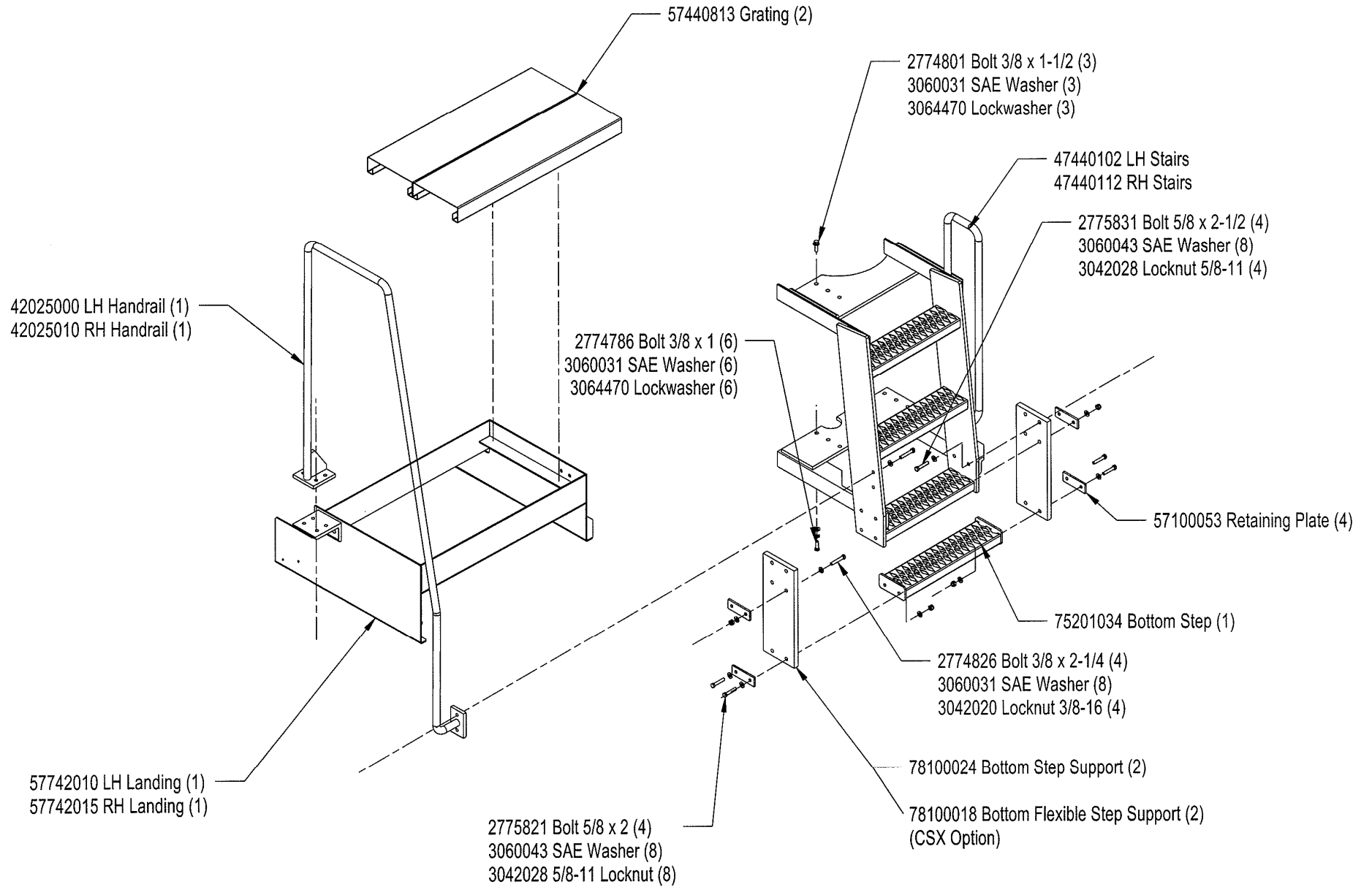
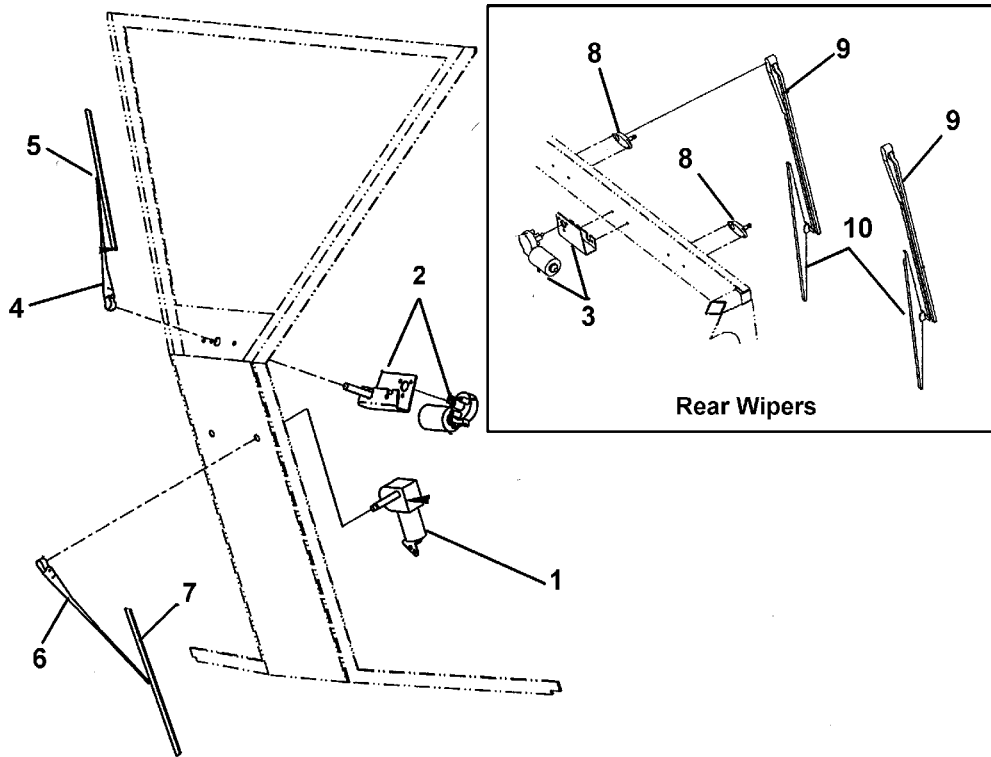

FIGURE 1-8. OPERATOR STATION Cab Wipers S/N 760163 and Above



ITEM NO.	NO.	DESCRIPTION	MACHINE
1	5021 1621	. MOTOR, Lower Wiper	2
2	5021 1625	. MOTOR, Wiper (Front/Upper)	1
3	5021 1625	. MOTOR Rear Window Wiper	1
4	1105 0004	. RADIAL WIPER ARM, Upper 18"	1
5	1776 0020	. . BLADE 20"	1
6	1105 0005	. RADIAL WIPER ARM, Lower 16"	2
7	1776 0030	. . BLADE 16"	1
8	1105 0050	. PANTOGRAPH ADAPTER KIT	2
9	1105 0002	. WIPER, Rear 18"	2
10	1776 0025	. . BLADE 14"	2
11	9676 0069	. HARNESS, Wiper	1

WIDE GAUGE AXLE

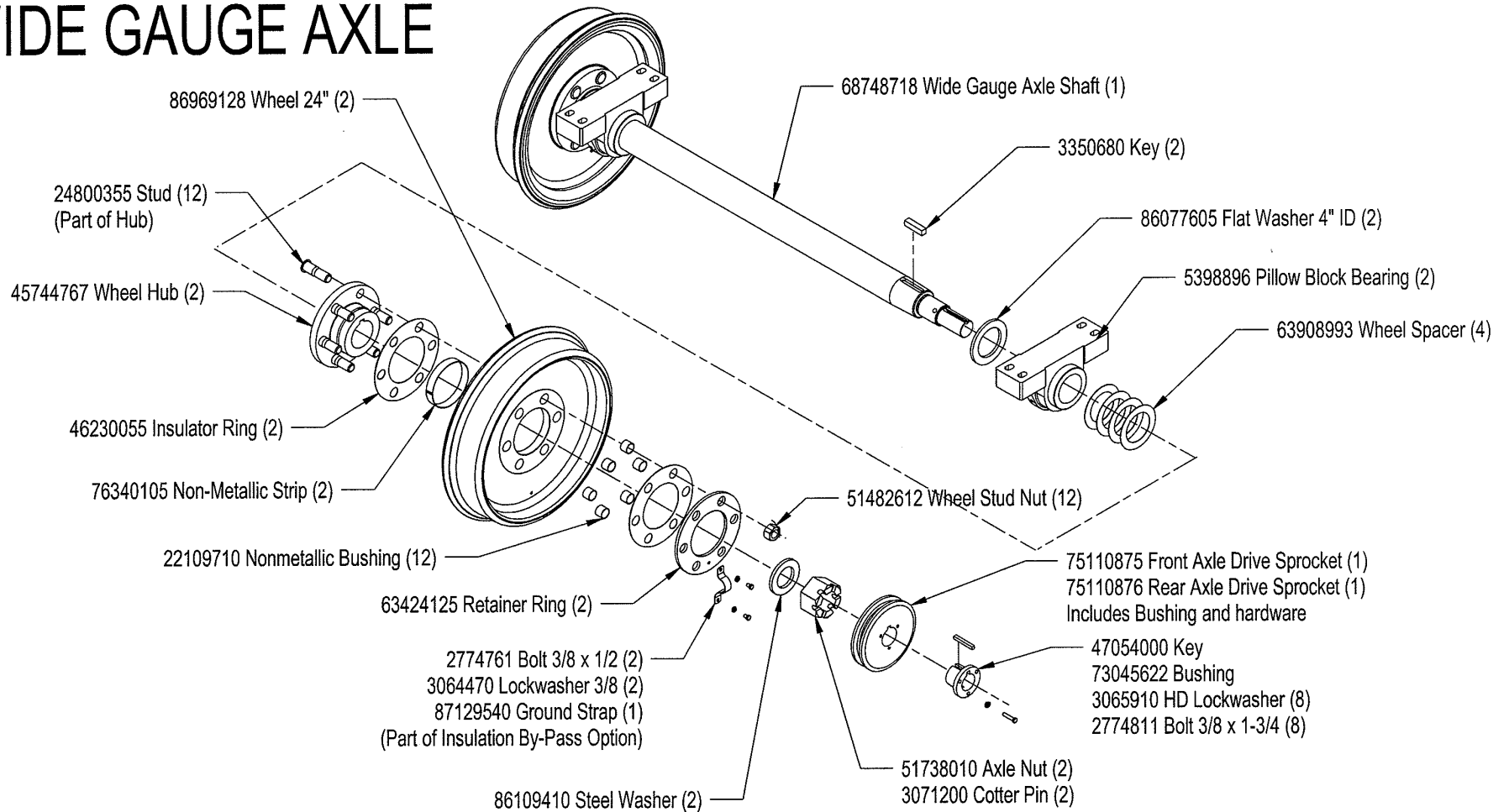

FIGURE 2-2. AXLES Insulation By-Pass Via Cab (Option)

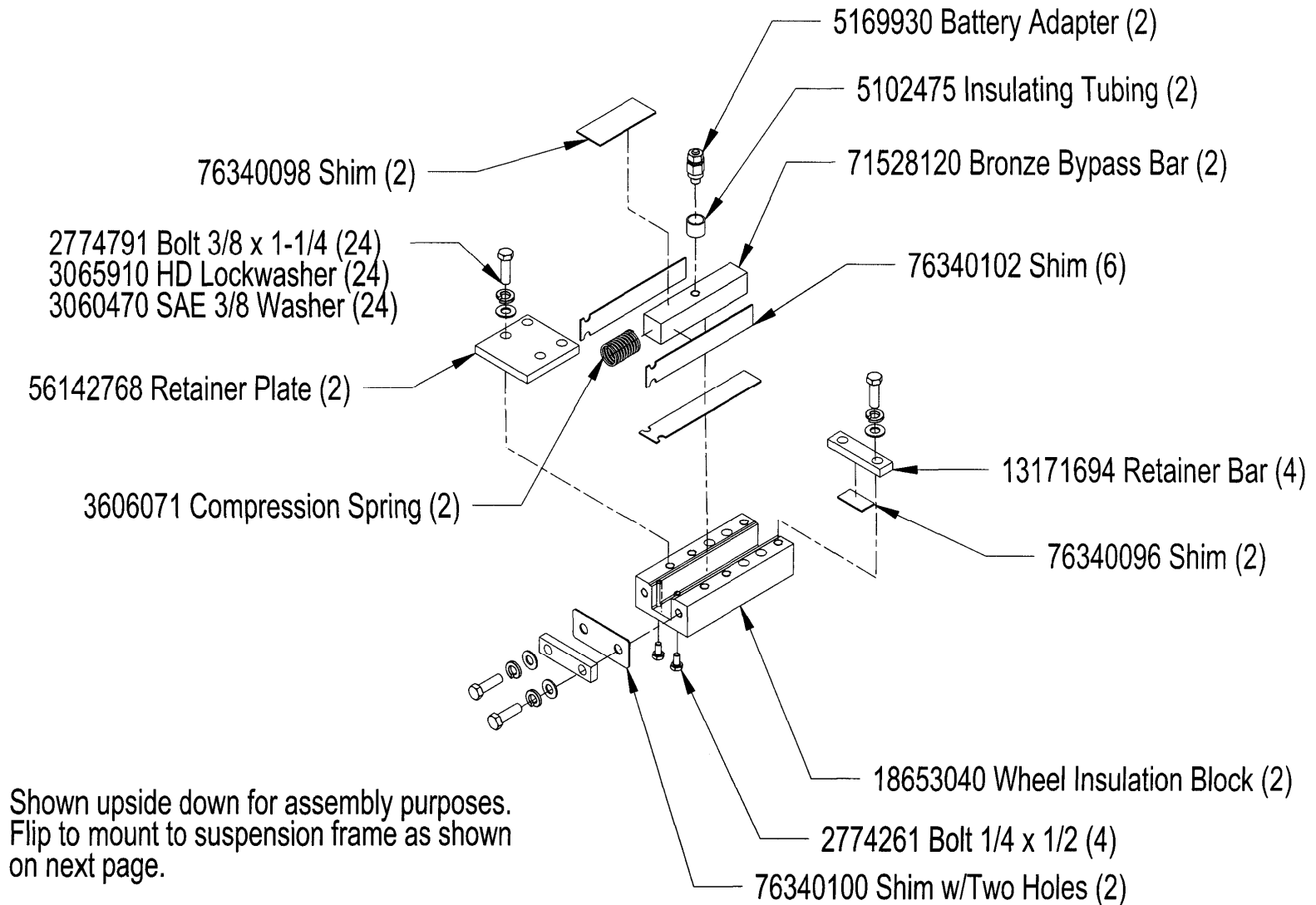
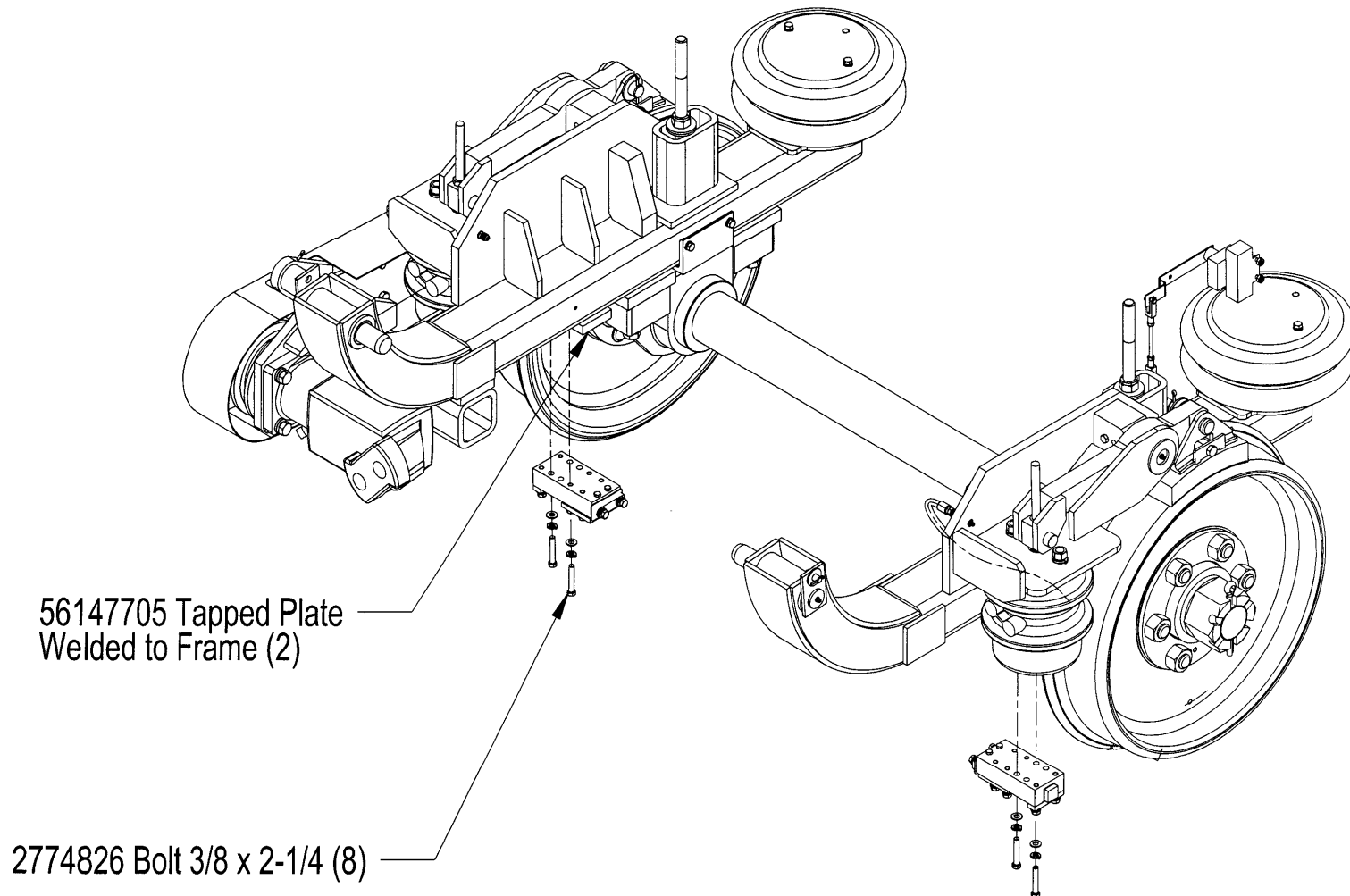

FIGURE 2-2. AXLES Insulation By-Pass Via Cab (Option)



See Electrical Section for Items
added to Cab Panels for this Option.

FIGURE 4-1. AIR SYSTEM BRAKES

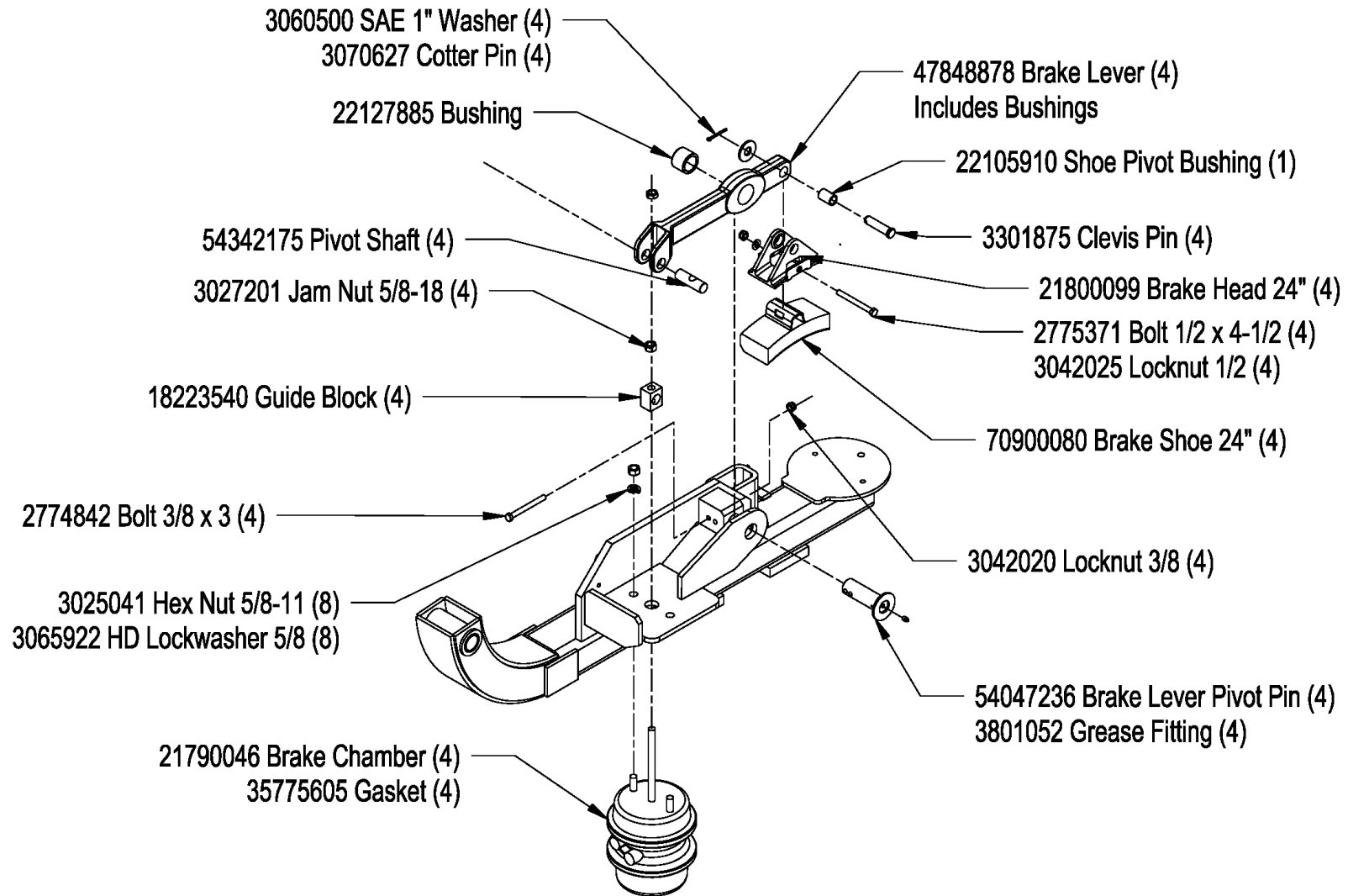

FIGURE 4-2. AIR SYSTEM Suspension S/N 760500 & Above

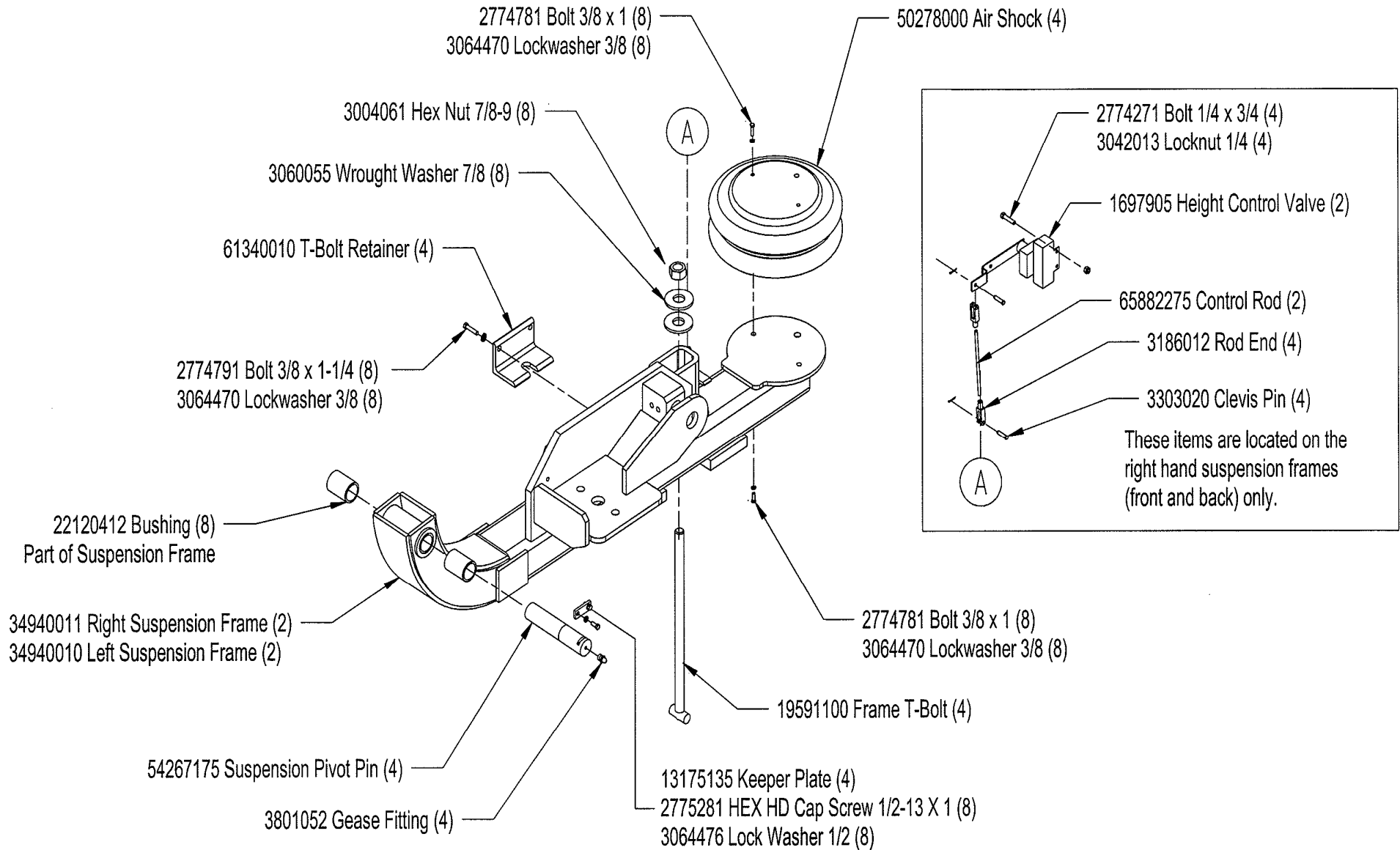

FIGURE 5-1. PROPULSION

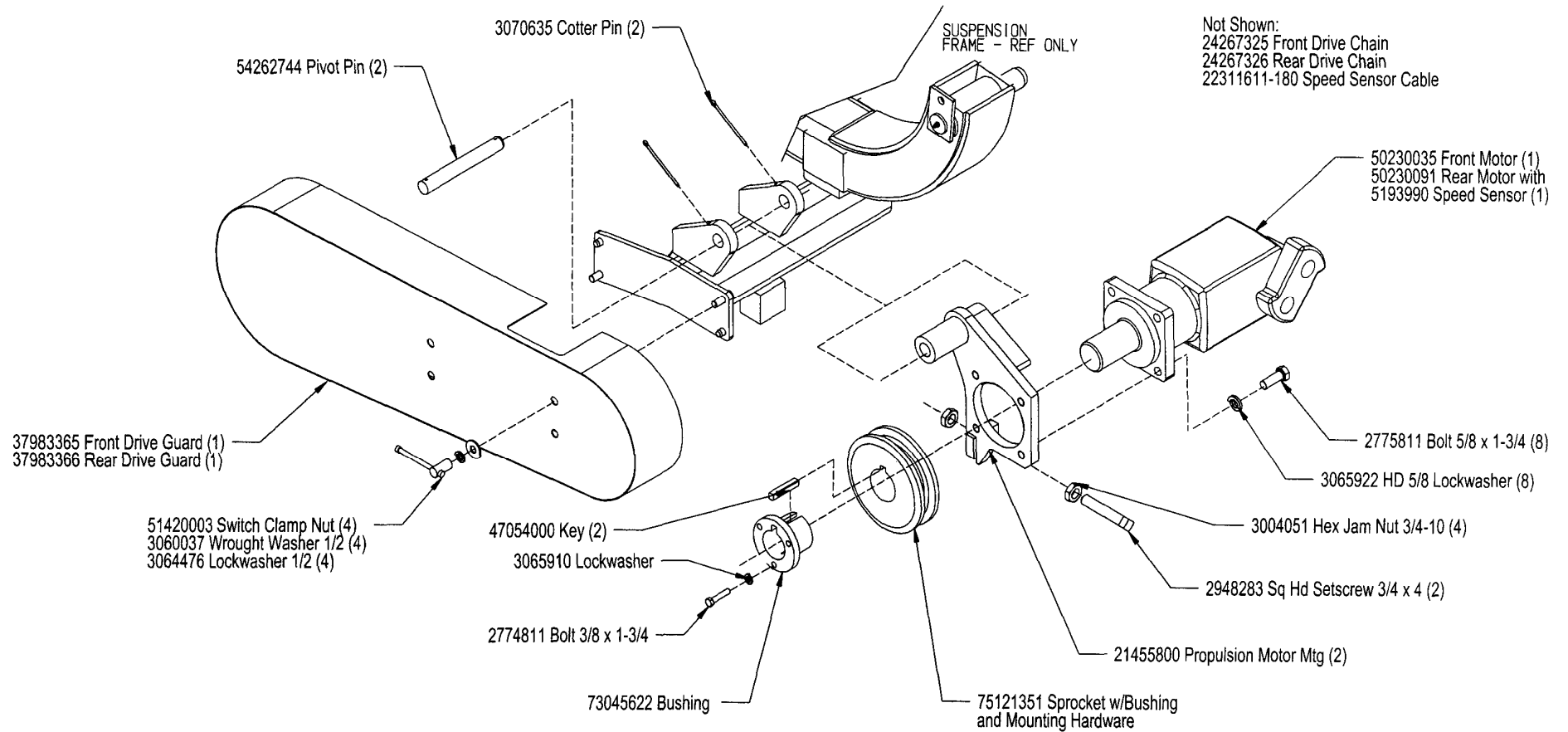
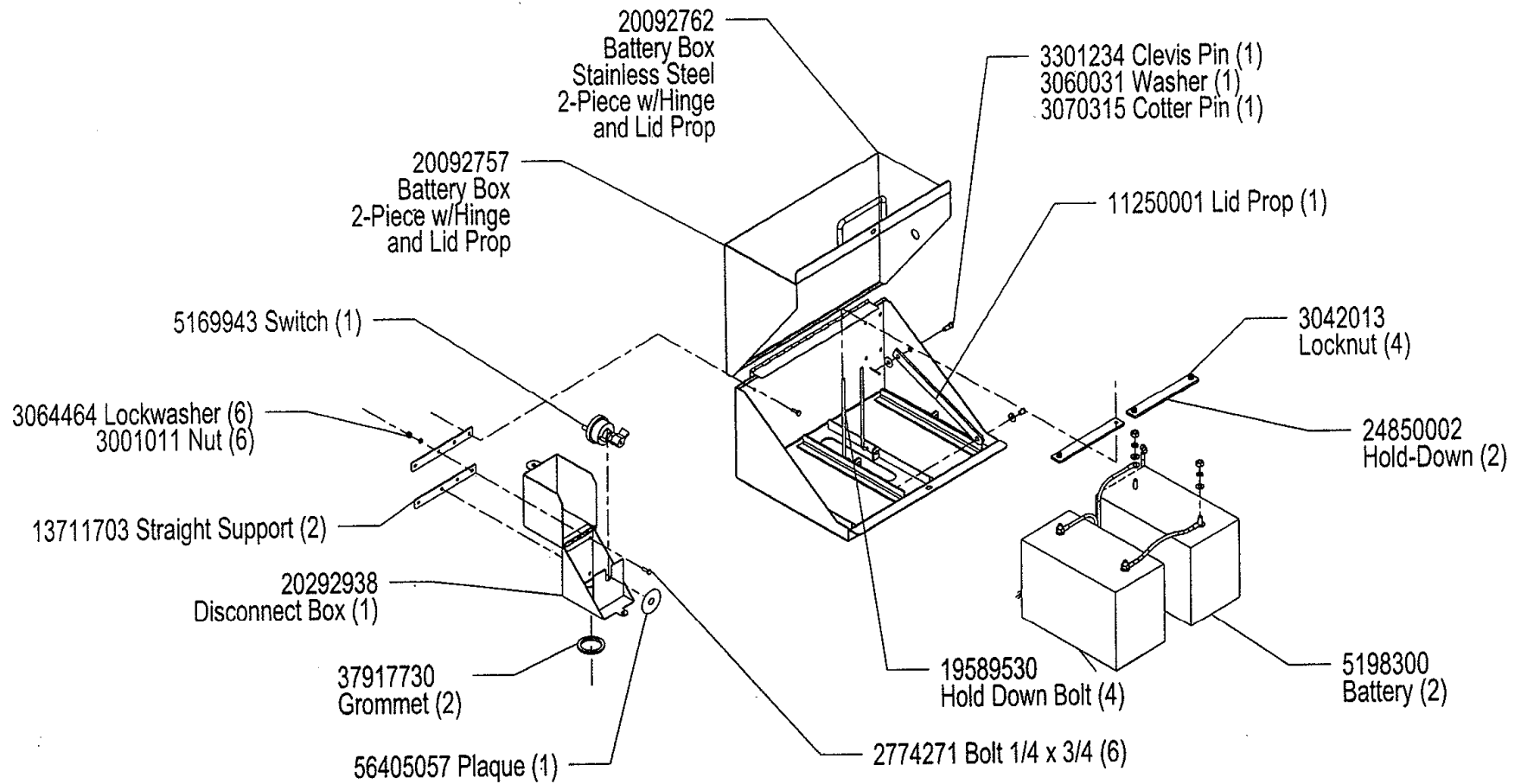
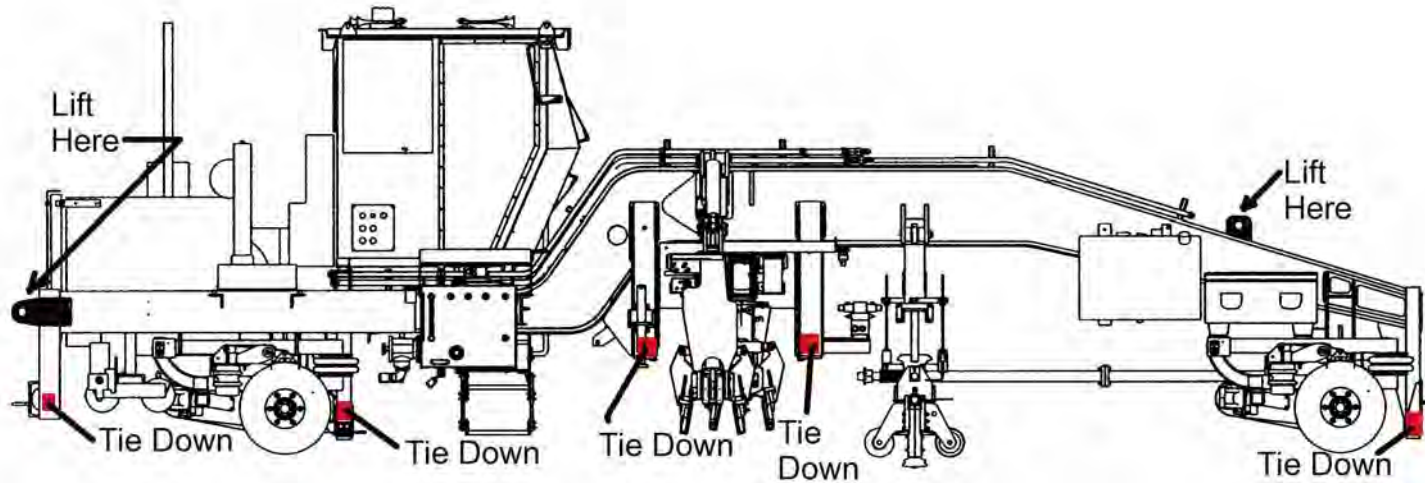





FIGURE 6-1. FRAME ACCESSORIES

Battery N31 24V



**FIGURE 6-2. FRAME ACCESSORIES
LIFTING DEVICES
S/N 760163 and Above**



Weight Restrictions on Slings (Style of Use)			
	Choker	Vertical	Basket
			
Nordco P/N			
8020 115	24,000	30,000	60,000
8020 120	12,000	15,000	30,000

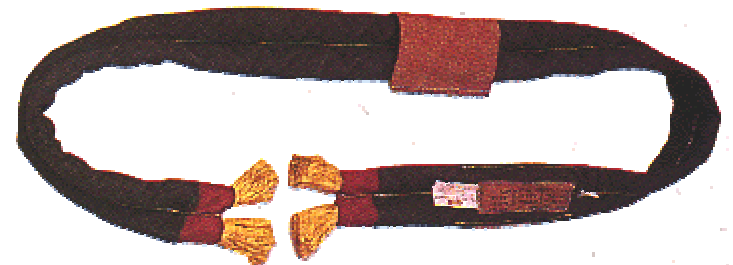



FIGURE 6-2. FRAME ACCESSORIES LIFTING DEVICES S/N 760163 and Above

ITEM NO.	NO.	DESCRIPTION	MACHINE
1	8027 350	SHACKLES.....	1
2	8020 115	SLING, Front Lifting	1
3	8020 120	SLING, Rear Lifting.....	2

PART UNITS PER

Two rear lifting straps **MUST ALWAYS** be used when lifting this machine.
Never attempt to raise machine using only one strap in the rear.



Crushing Hazard.
Do not attempt to lift machine By Tie Downs!
Do not attempt to lift machine using only one strap at rear!
Use provided Lifting points.

FIGURE 6-3. FRAME ACCESSORIES Tool Box

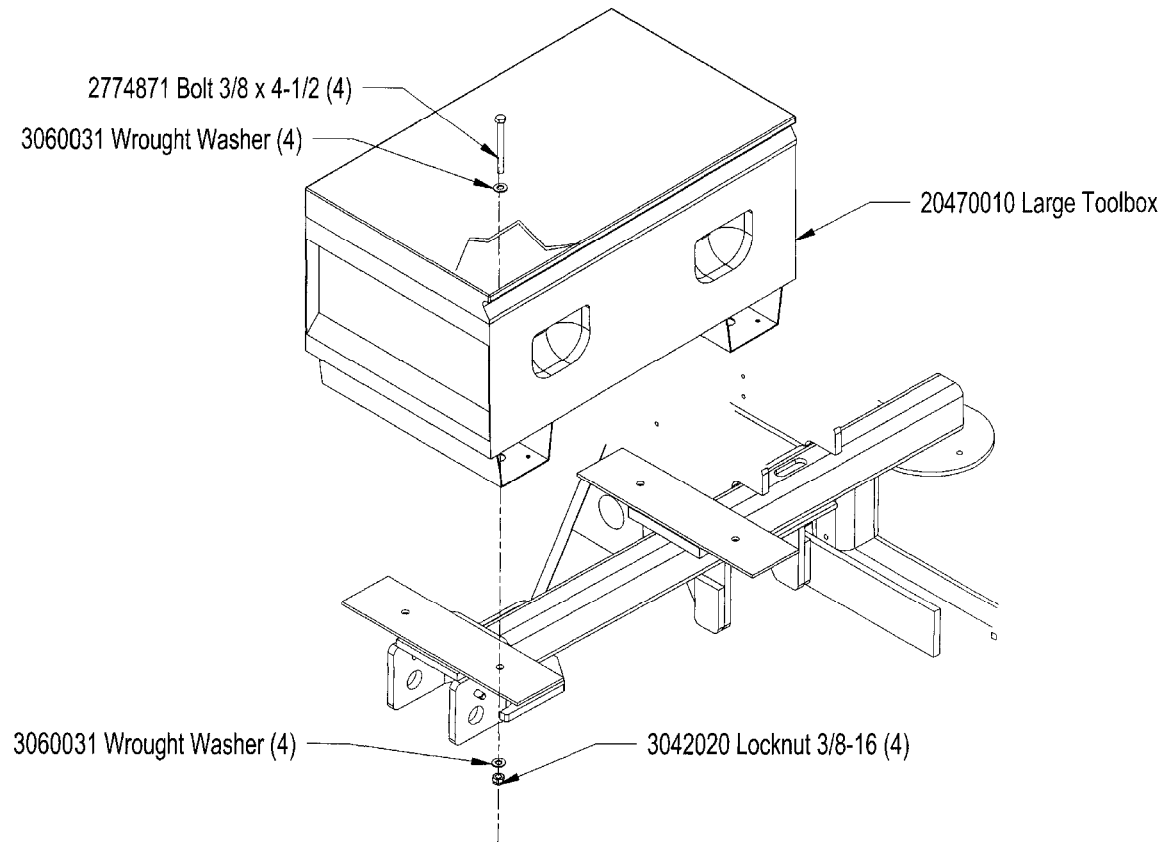

FIGURE 6-4. FRAME ACCESSORIES Derail Assemblies

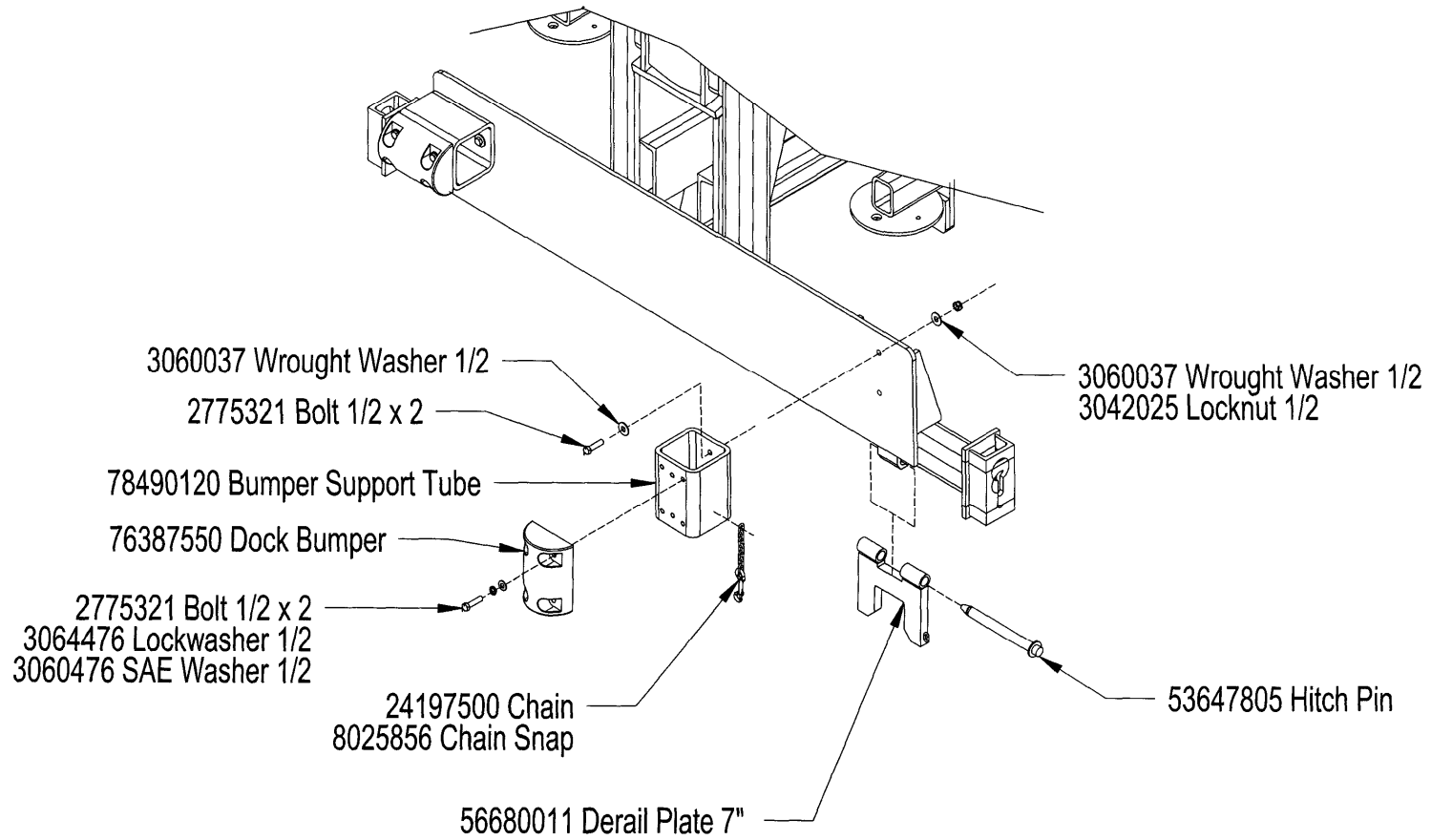
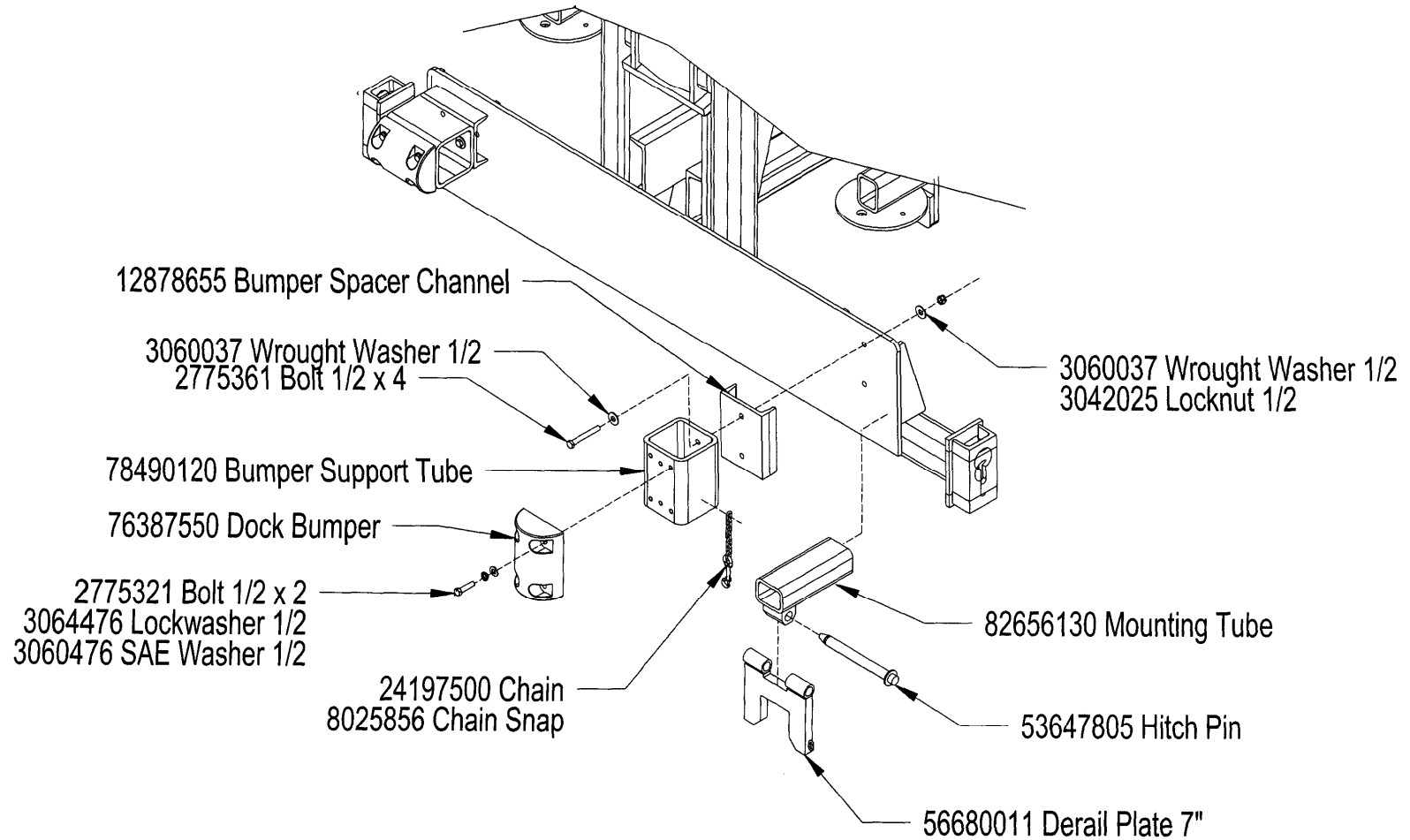
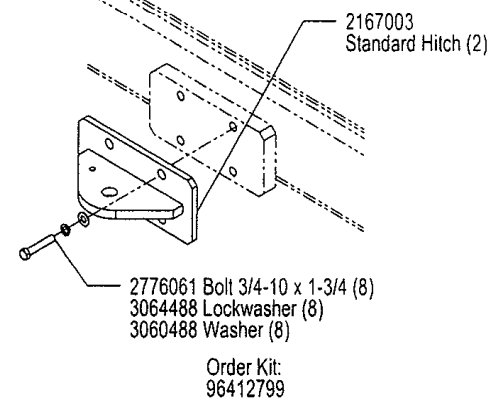
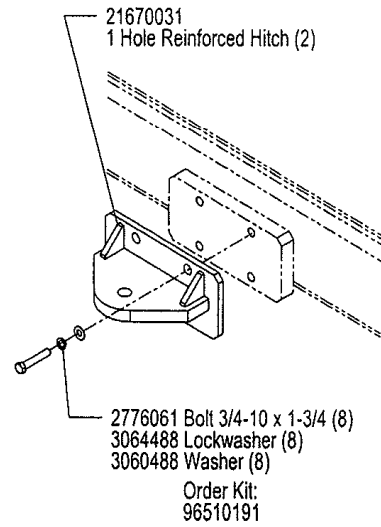
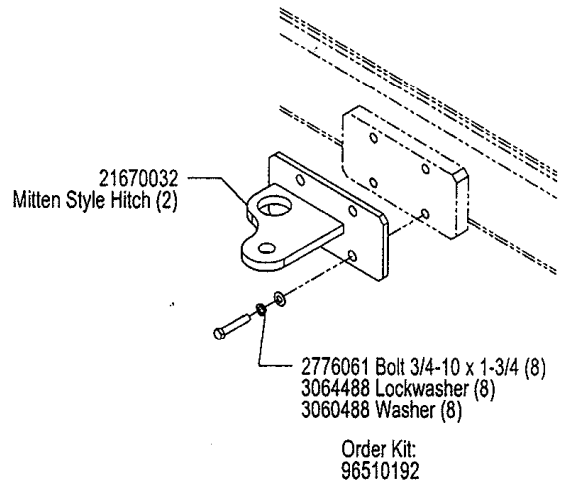

FIGURE 6-4. FRAME ACCESSORIES Derail Assemblies



Derail Extension Option

FIGURE 6-5. FRAME ACCESSORIES Hitches



Not Shown: 14760017 Tow Bar (Option)

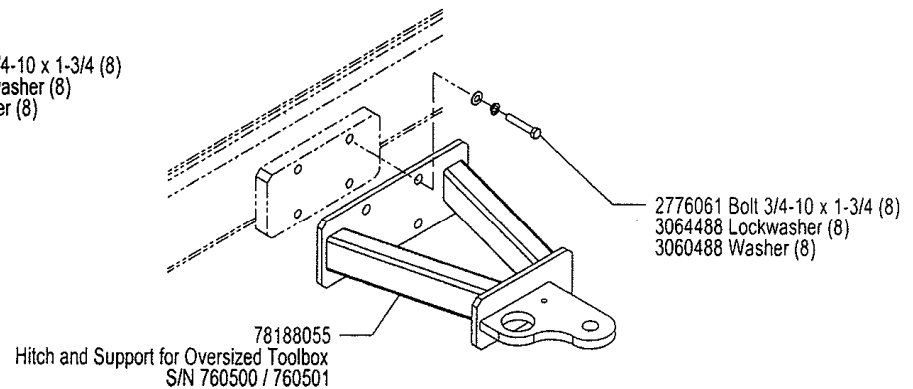
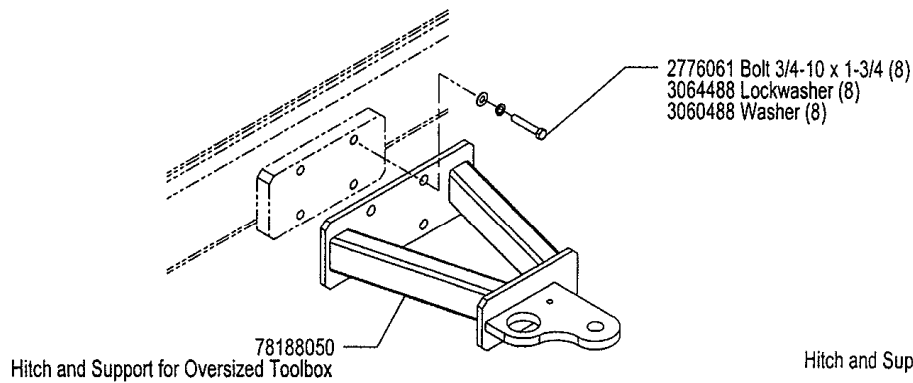

FIGURE 6-6A. FRAME ACCESSORIES

Perimeter Lighting

S/N 760398 and Above

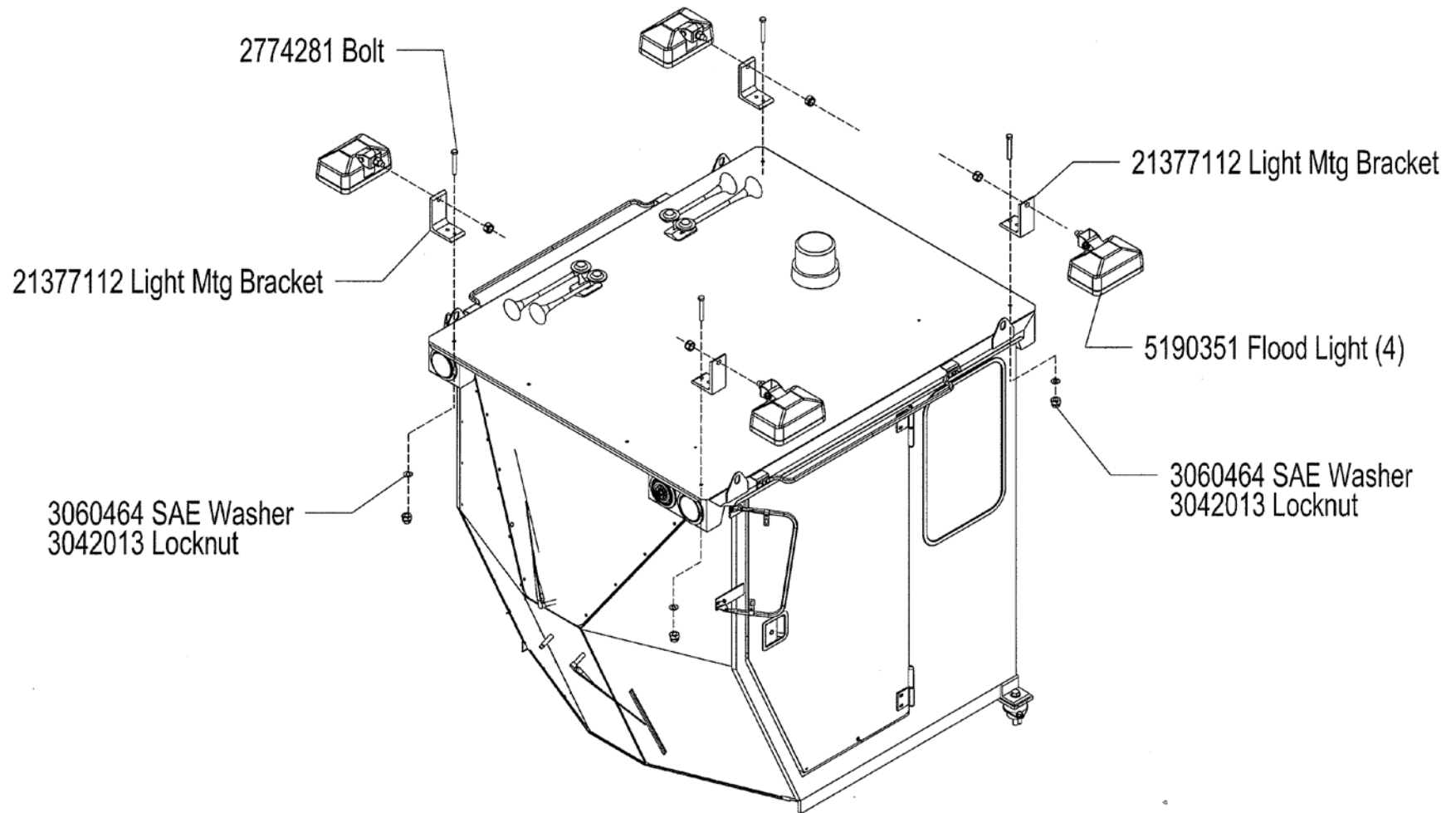

FIGURE 6-6A. FRAME ACCESSORIES Perimeter Lighting S/N 760398 and Above

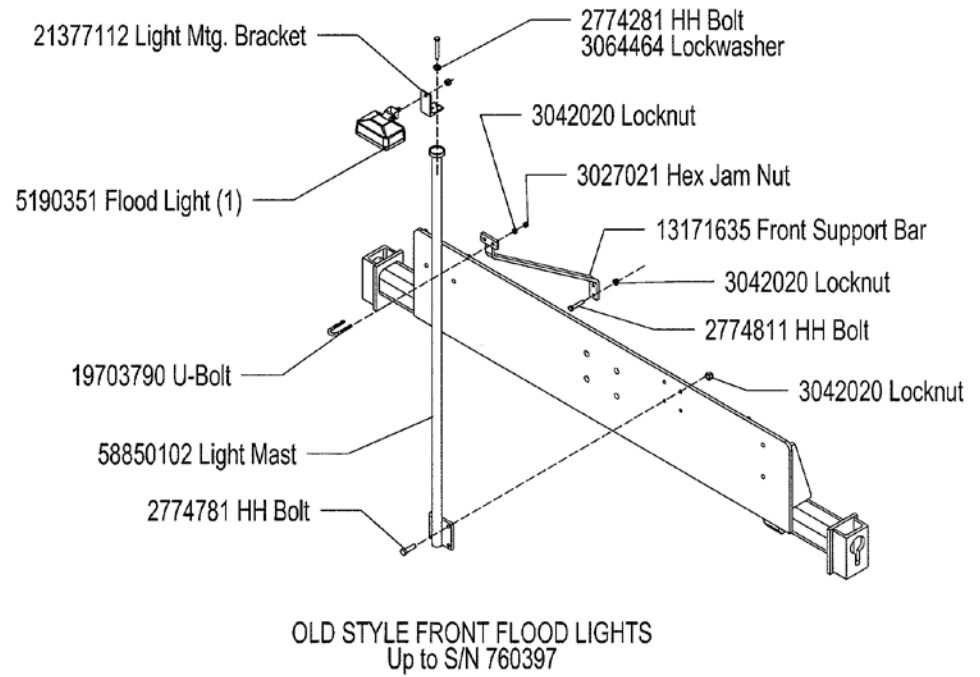
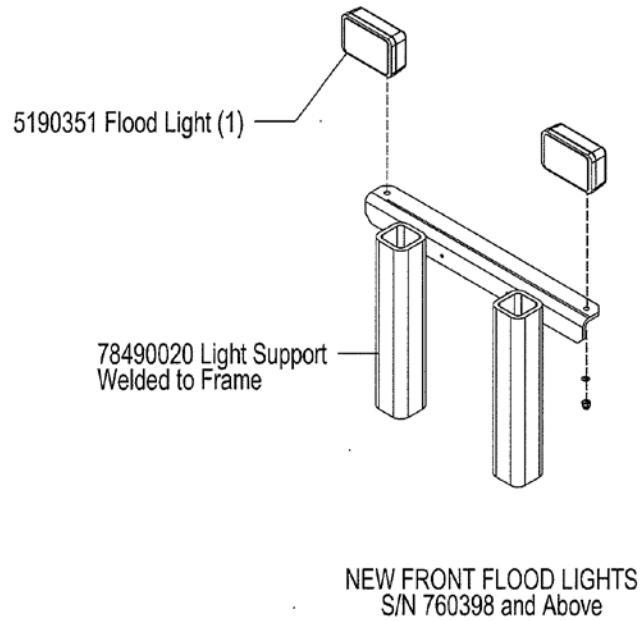
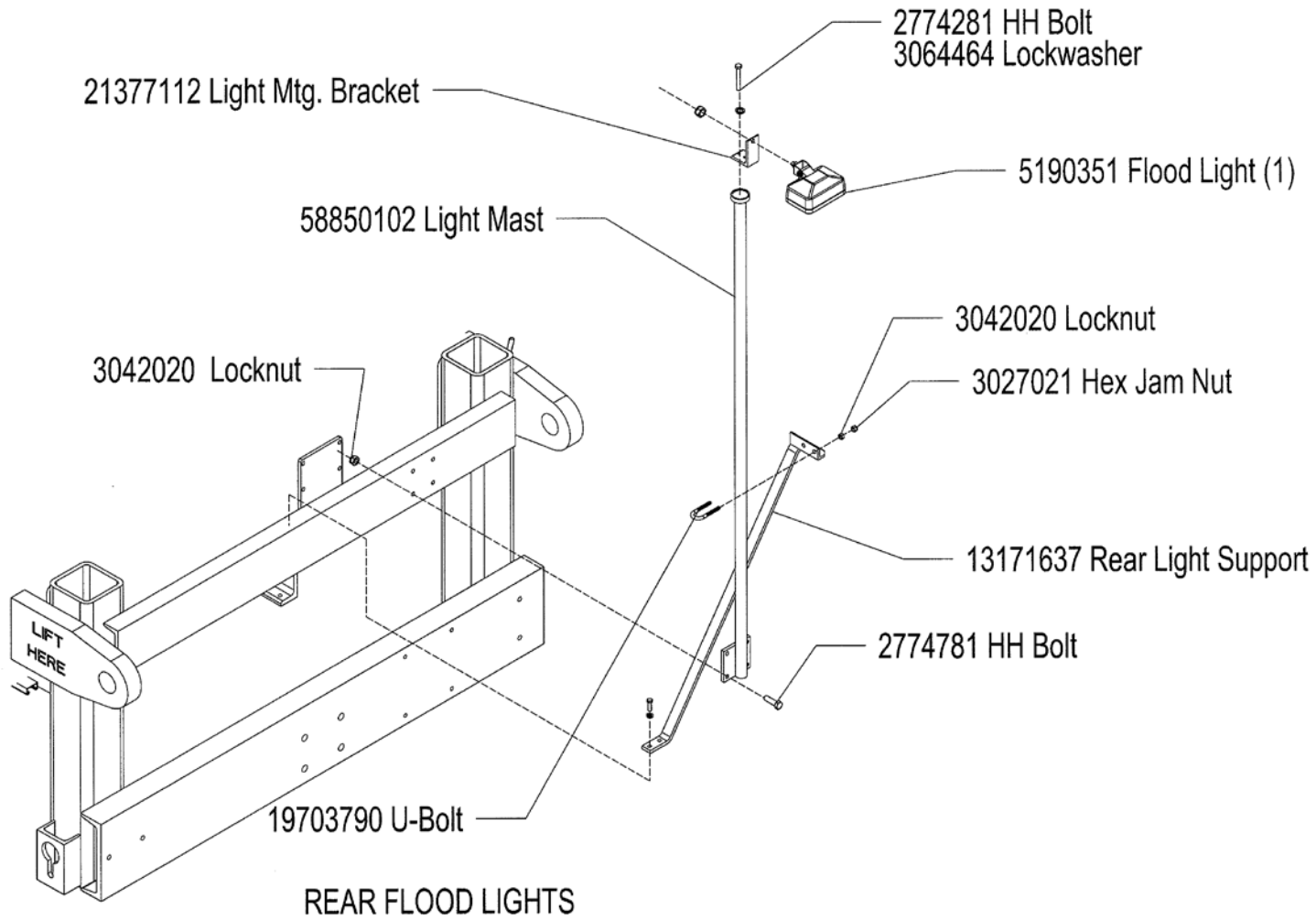

FIGURE 6-6A. FRAME ACCESSORIES

Perimeter Lighting

S/N 760398 and Above



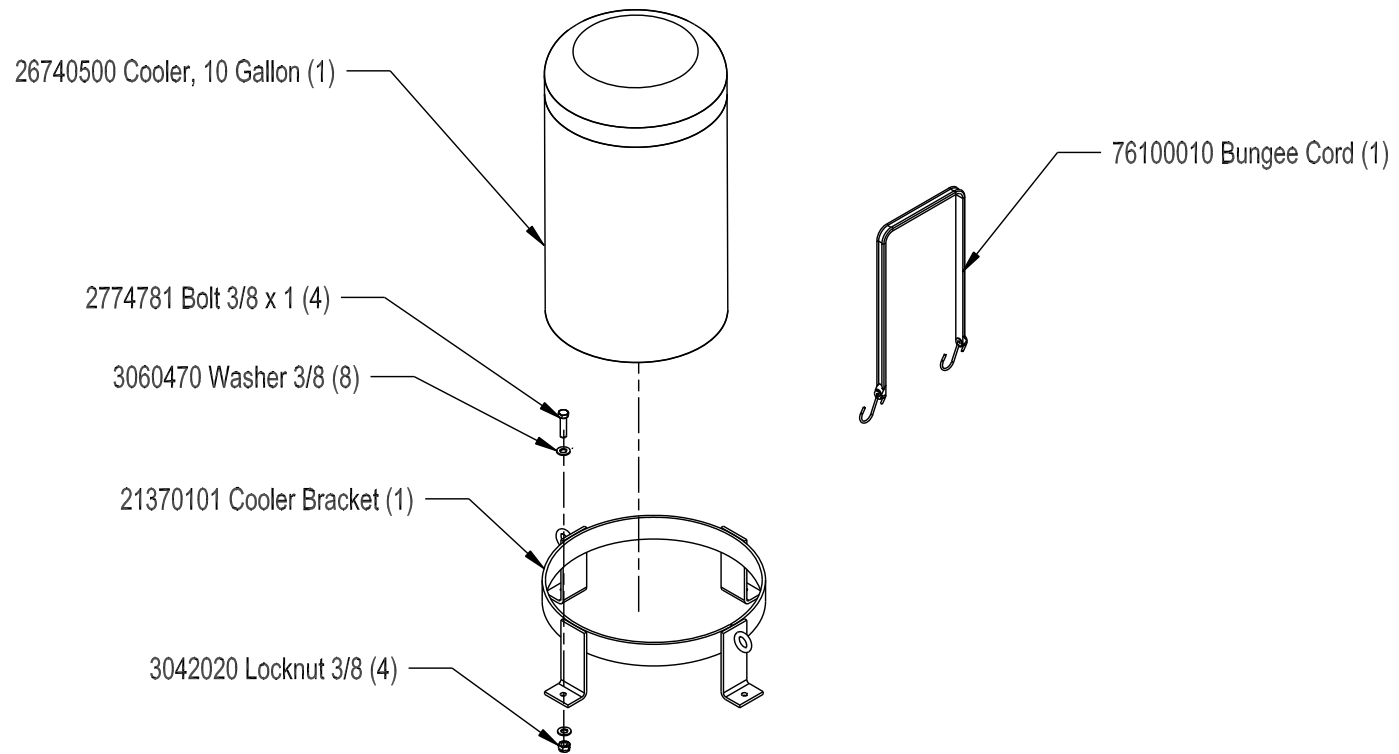

FIGURE 6-9 Air Powered Lubrication Option

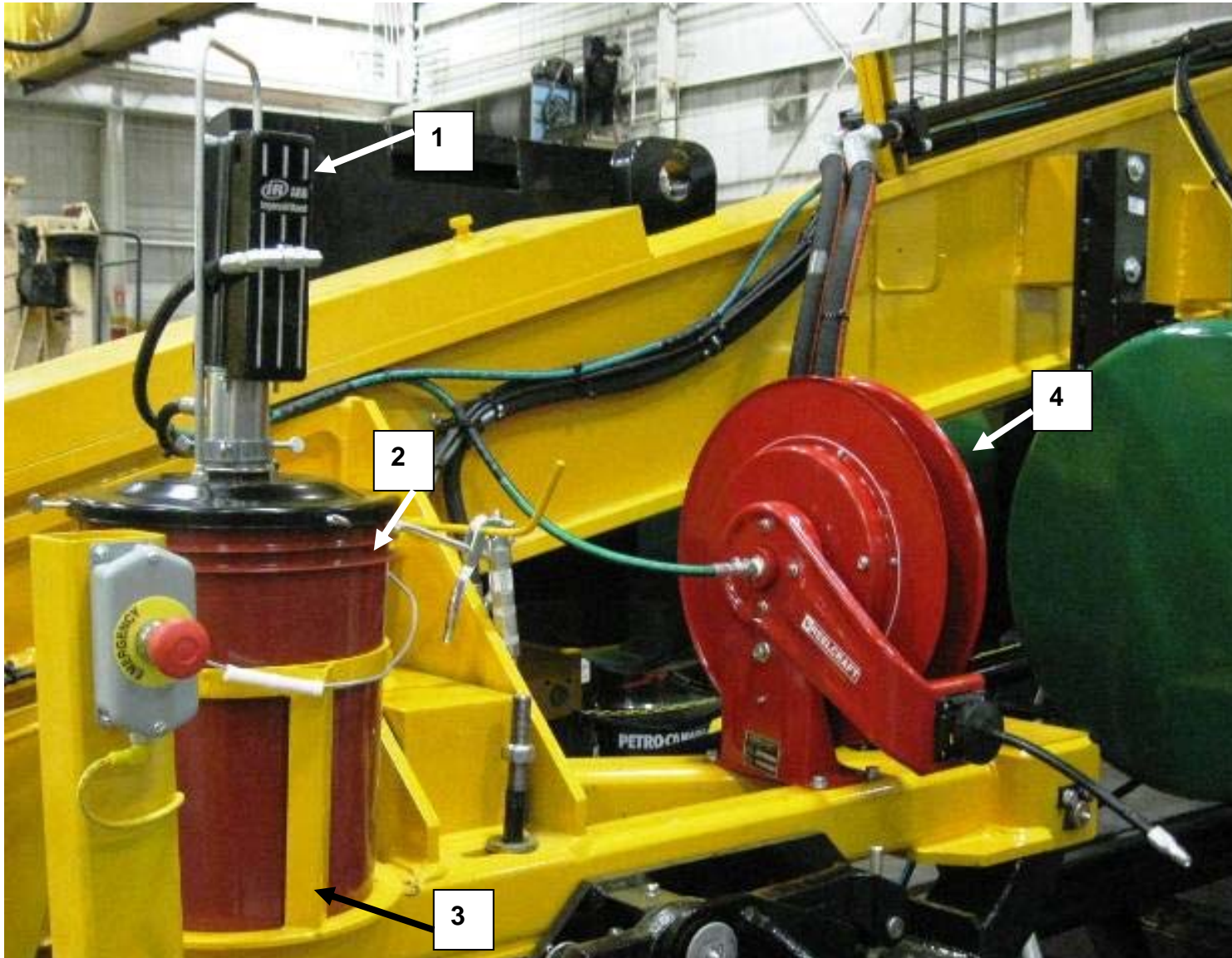
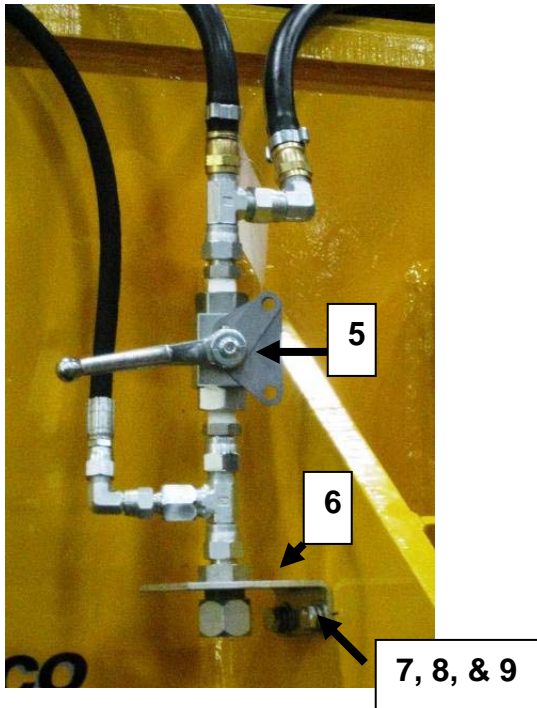

FIGURE 6-9 Air Powered Lubrication Option



ITEM NO.	PART NO.	DESCRIPTION	UNITS PER ASSEMBLY
1	3803100	. Lubricator, Air Powered.....	1
2	4806183	. Grease, Mobilux EP#2	1
3	21000188	. Bracket, Holder Pail Greaser.....	1
4	3804001	. Reel, High Pressure Grease Hose	1
5	1605826	. Valve, Ball High Pressure	1
6	13710013	. Bracket, Remote Drain	1
7	2774771	. CPSCR HX 3/8-16 X 3/4	2
8	3064470	. Washer, Lock 3/8	2
9	3060470	. Washer, SAE 3/8.....	2
10*	24192996	. Chain, 2 OP X 42 Links	1
11*	19700715	. U-Bolt, 3/4'	2
12*	3064464	. Washer, Lock 1/4"	4
13*	3001011	. Nut Hex, 1/4 X 20	4
14*	10286150	. Disconnect, Male 1/4 NPTF	1
15*	10281073	. Disconnect, Female 1/4 NPTF	1

FIGURE 7CU-1 CUMMINS ENGINE QSB5.9

NOTICE

When calling Cummins NPower for support on this Engine, Reference the engine number listed below. Make certain you Have the S/N of the engine available at time of service call.

31750192

Rated Horsepower: 185hp@2500 rpm
Operating RPM: 2400 rpm high idle
1100 rpm low idle

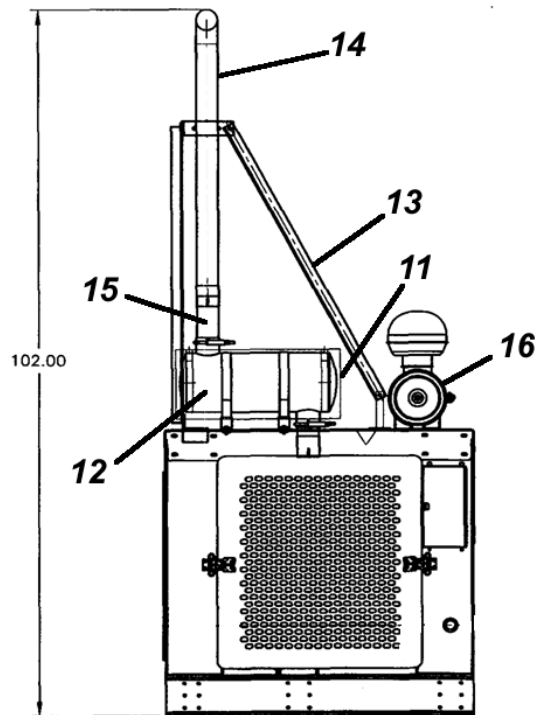

ITEM NO.	PART NO.	DESCRIPTION	UNITS PER ASSEMBLY
1	31750192	Cummins QSB5.9 Engine	1
2	5128944	80 Amp Circuit Breaker	1
3☉	EE 9127	70 Amp Alternator (Delco 22SI).....	1
4	Contact Nordco	Starter Relay	1
5	74130043	Throttle Solenoid.....	1
6	Contact Nordco	Timer Module.....	1
7	5193962	Water Temp Sender (VDO).....	1
8	5193951	Oil Pressure Sender (VDO)	1
10☉	LC 9020	Engine Oil Cooler.....	1
11	38042632	Muffler Heat Shield	1
12☉	1000521	Muffler	1
13	98412437	Exhaust Pipe Brace	1
14	82655410	Tailpipe	1
15	82655411	Exhaust Pipe 3 x 9".....	1
16	Contact Nordco	Air Cleaner.....	1
19☉	KO0-01-014	Dual Pump Drive (Durst)	1
20☉	CP 9340	Air Compressor (Wabco 15.2 cfm).....	1

CONSUMABLES/WEAR ITEMS:

30	6090565	Fuel/Water Separator (FS19732)	1
31	6090843	Fuel Filter (FF5421)	1
32	3894606	Oil Filter (LF3970).....	1
33	17560030	Serpentine Belt (3289809).....	1
34☉	3894670	Air Filter, Primary (P777639)	1
35☉	3894671	Air Filter, Safety (P778214)	1

☉ This number is a Cummins or Cummins NPower Part Number

FIGURE 7CU-1 CUMMINS ENGINE QSB5.9

NOTICE

The following drawing and part numbers are
Those of Cummins NPower.

When calling Cummins NPower for support on this Engine,
Reference the engine number listed below. Make certain you
Have the S/N of the engine available at time of service call.

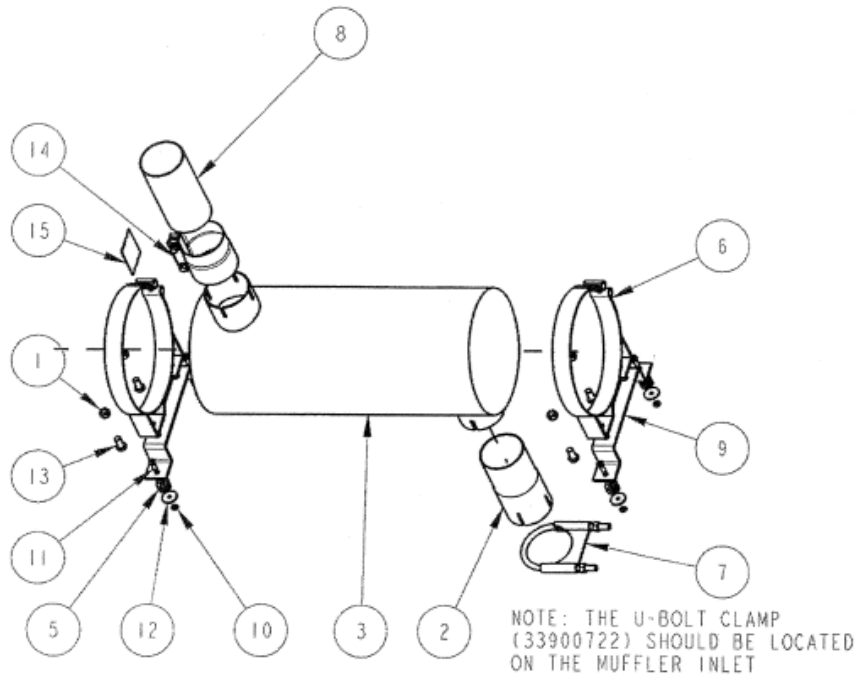

ITEM NO.	PART NO.	DESCRIPTION	UNITS PER ASSEMBLY
1	31750192	Cummins QSB5.9 Engine	1
2	5128944	80 Amp Circuit Breaker	1
3C	EE 9127	70 Amp Alternator (Delco 22SI).....	1
4	Contact Nordco	Starter Relay	1
5	74130043	Throttle Solenoid.....	1
6	Contact Nordco	Timer Module.....	1
7	5193962	Water Temp Sender (VDO).....	1
8	5193951	Oil Pressure Sender (VDO)	1
10C	LC 9020	Engine Oil Cooler.....	1
11	38042632	Muffler Heat Shield	1
12C	1000521	Muffler	1
13	98412437	Exhaust Pipe Brace	1
14	82655410	Tailpipe	1
15	82655411	Exhaust Pipe 3 x 9".....	1
16	Contact Nordco	Air Cleaner.....	1



NOTICE

Due to the different configurations available for engines, drawings will not be provided. The following list details this engine only. When calling Nordco for support on this Engine, make certain you have the S/N of the engine available at time of service call.

Rated Horsepower: 185hp@2500 rpm
 Operating RPM: 2400 rpm no load
 1100 rpm low idle

ITEM NO.	PART NO.	DESCRIPTION	UNITS PER ASSEMBLY
1	31750293	Cummins QSB6.7 Tier 3l	1
--	5128788	80 Amp Circuit Breaker.....	1
--C	EE0924700	Alternator.....	1
--		Radiator.....	1
2	100000162	Air Cleaner Assembly (See Wear Items) ..	1
3		Exhaust Stack Elbow	1
4C	15340	Exhaust Pipe	1
5C	10000641	Horizontal Muffler	1
6C	11000395	Stone Guard.....	1
7		Door Latch Assembly.....	1
--	47520610	Draw Latch	4
--	47520612	Secondary Keeper Latch.....	4
--	13225680	Keeper Latch.....	4
8C	13438	Exhaust Brace.....	1
9C	D12305	Drive Assembly (Durst)	1
10C	1000490	Door Handle	4
11C	CP0957400	A/C Compressor Assembly.....	1

**FIGURE 7CU-2. CUMMINS ENGINE
 Cummins QSB6.7 Tier 3
 with A/C Compressor**

CONSUMABLES/WEAR ITEMS:

ITEM NO.	PART NO.	DESCRIPTION	UNITS PER ASSEMBLY
25C	FF5421	Fuel Filter (Primary)	1
26C	FS19732	Pre-Filter Fuel/Water Separator	1
27	3894606	Oil Filter (LF3970).....	1
28C	3289941	Fan Belt	1
29C	AF1828	Primary Air Filter (Napa 2493)	1
30C	AF1894M	Safety Air Filter (Napa 2494)	1

C This Indicates Cummins or Cummins NPower Part Numbers.

NOISE DEFLECTOR INSTALLATION INSTRUCTIONS

1. PRIOR TO ASSEMBLY IT WILL BE NECESSARY TO LAYOUT AND DRILL SIX (6) .438 DIAMETER HOLES IN THE UPPER CHANNEL OF THE TRIPP MAIN FRAME AT THE LOCATIONS SHOWN IN VIEW AT RIGHT.
2. AN ALTERNATE METHOD IS TO CLAMP THE NOISE DEFLECTOR TO THE FRAME MEMBER ALIGNING ON THE ENGINE RADIATOR AND USING THE HOLES IN THE DEFLECTOR AS A GUIDE DRILL THE .438 DIAMETER HOLES THROUGH THE WEB AND UPPER FLANGE OF THE FRAME CHANNEL.
3. ATTACH THE GUARD TO THE FRAME WITH THE HARDWARE SHOWN BELOW AND FOUND IN THE KIT, BOLTING THROUGH THE WEB AND FLANGE OF THE CHANNEL.

NOTE:
NORDCO DOES NOT RECOMMEND WELDING THIS SHIELD TO THE MACHINE FRAME

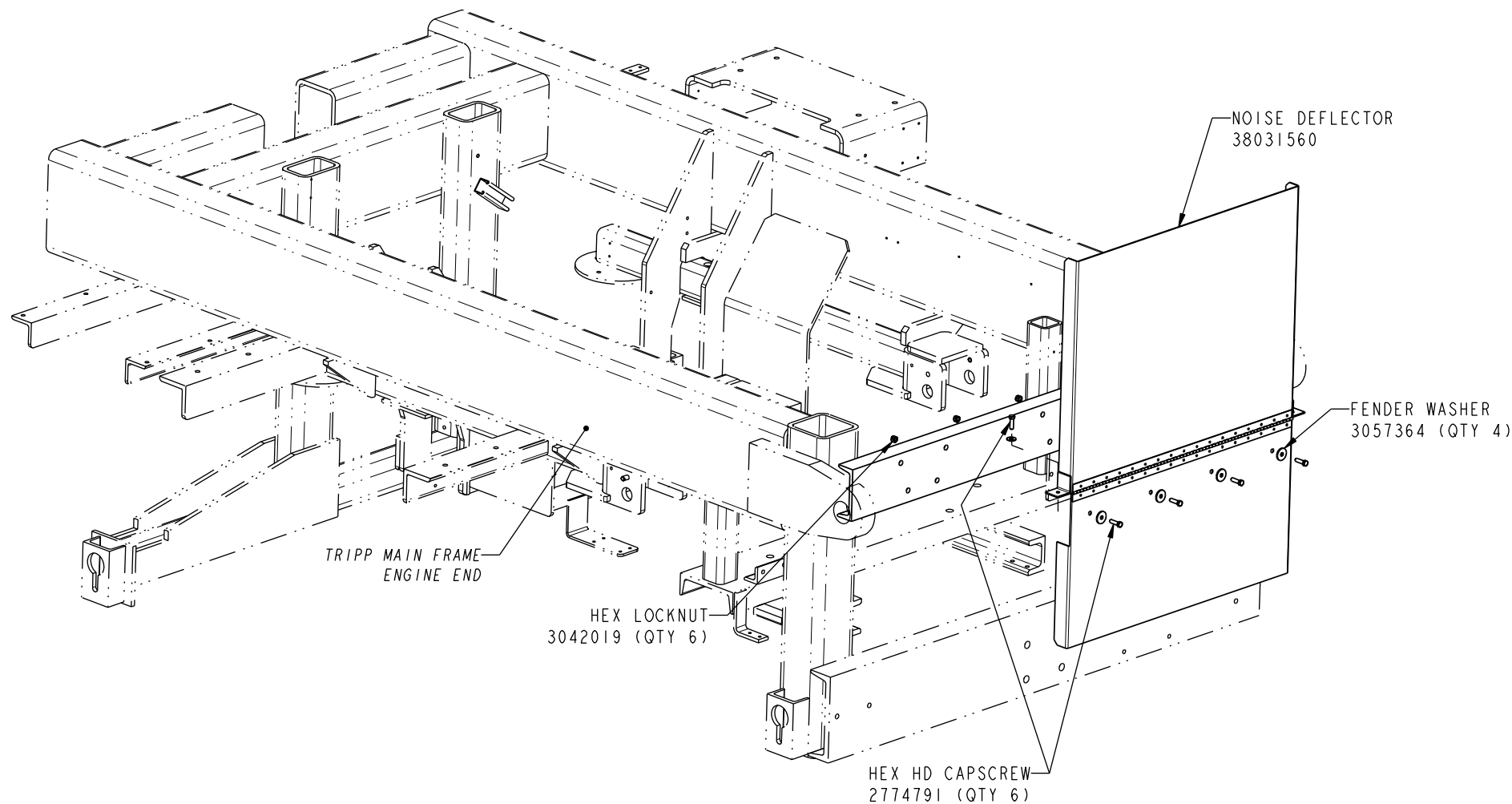
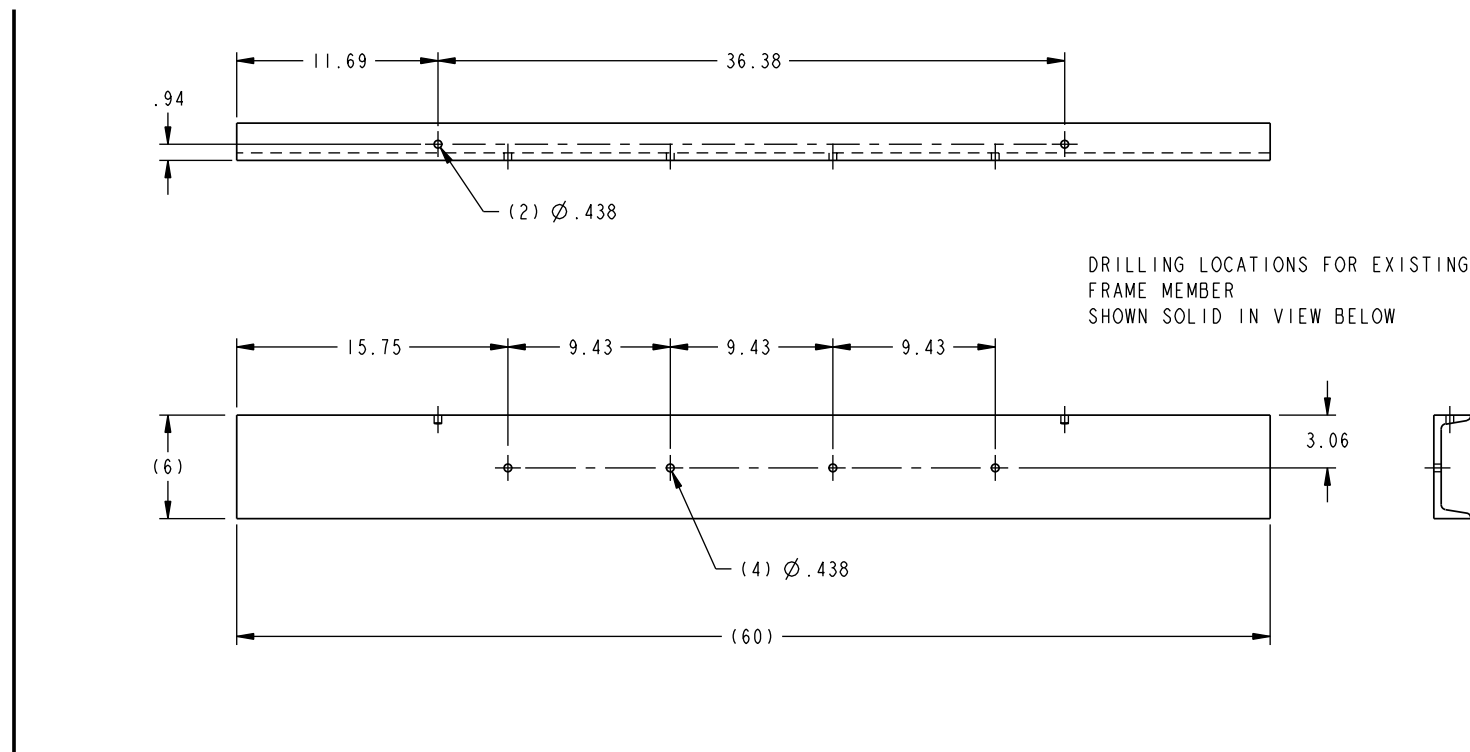

CUSTOMARY: ALL DIMENSIONS IN INCHES					
IMPLIED TOLERANCES		PRODUCT: TRIPP			
DESCRIPTION: NOISE DEFLECTOR INSTALL		DRAWING CODE NUMBER			
FRACTION	± 1/8	SIZE	SCALE	ASSEMBLY: 98760065	REV.
.X	± .06	D	1/8	97765048DWG	-
.XX	± .03				
.XXX	± .010				
MACHINE FINISH UNLESS OTHERWISE STATED		SHEET 1 OF 1			

PRODUCTION RELEASE	LCP	600098
DATE: 08/11/09	CHECKED BY:	DATE:
DATE:	APPROVED BY:	DATE:
E.C.O. #		

FIGURE 8-1. HYDRAULIC TANK 85 Gallon

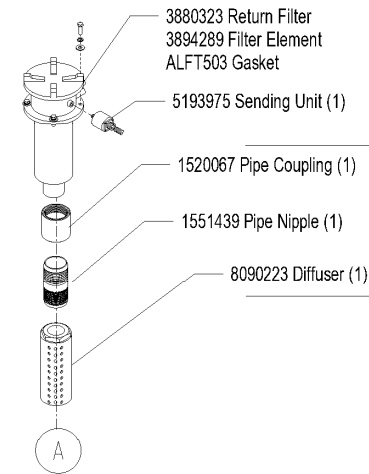
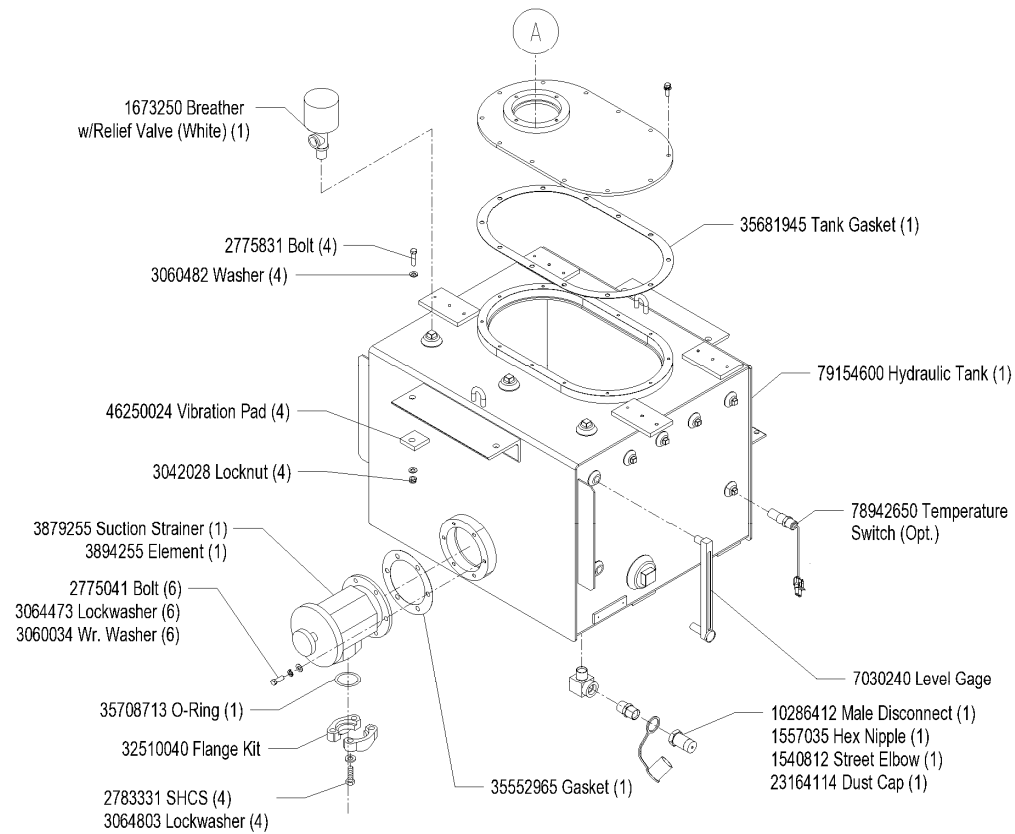

Std S/N 760367 & Above
Optional Below S/N 760367

Not Shown:
56400119 Minimum Oil
Level Decal (1)

FIGURE 9-1. OIL COOLER

S/N 760163 and Above

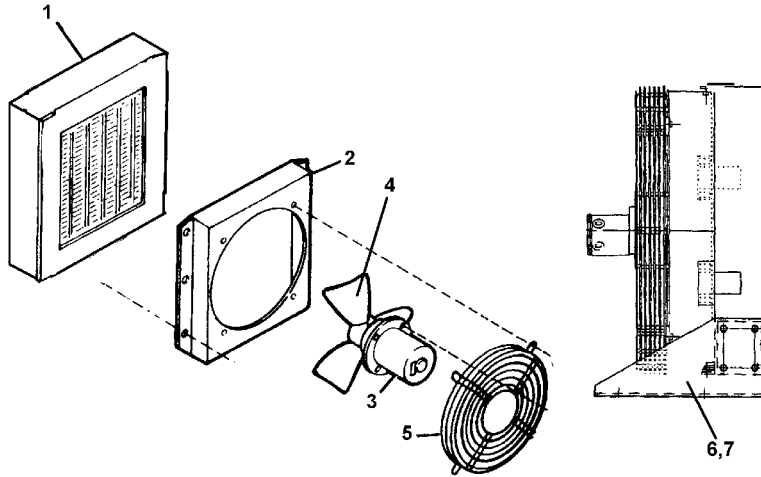

ITEM NO.	PART NO.	DESCRIPTION	UNITS PER MACHINE
--	2674 0204	.OIL COOLER ASSEMBLY	1
1	6057 0042	.. COOLER, Oil.....	1
2	3804 0007	.. SHROUD, Fan	1
3	5021 1528	.. MOTOR, Hydraulic.....	1
4	1028 5201	.. FAN	1
5	3804 0008	.. GUARD, Finger	1
6	2100 0154	.. BRACKET, Left Mounting	1
7	2100 0155	.. BRACKET, Right Mounting	1
8*	9676 0172	OIL COOLER GUARD ASSEMBLY...	1
--	3803 7625	. GUARD, Cooler.....	1

FIGURE 10. FUEL TANK 120 Gallon

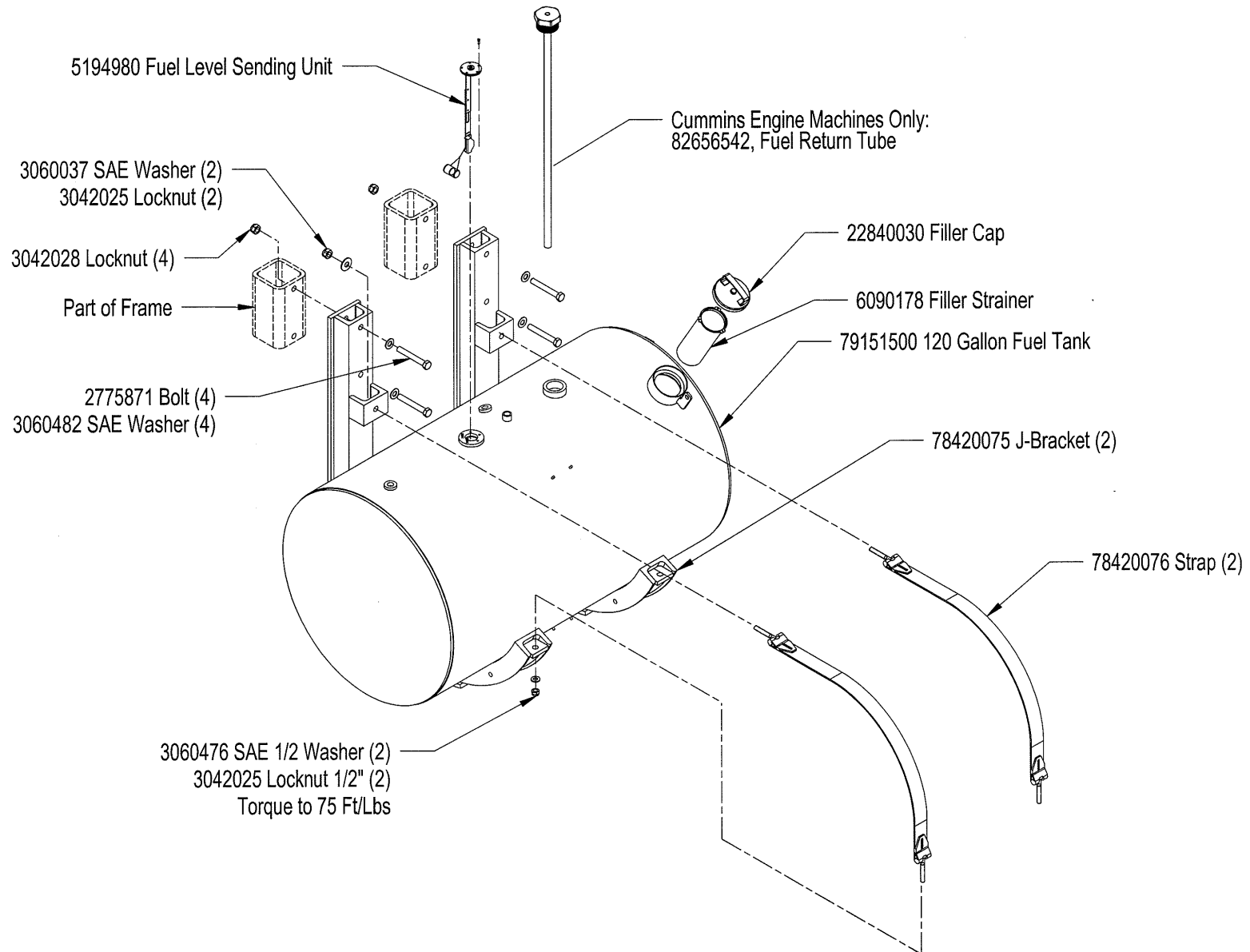

FIGURE 13B-1A. TIE EXCHANGER MAIN FRAME S/N 760355 and Above

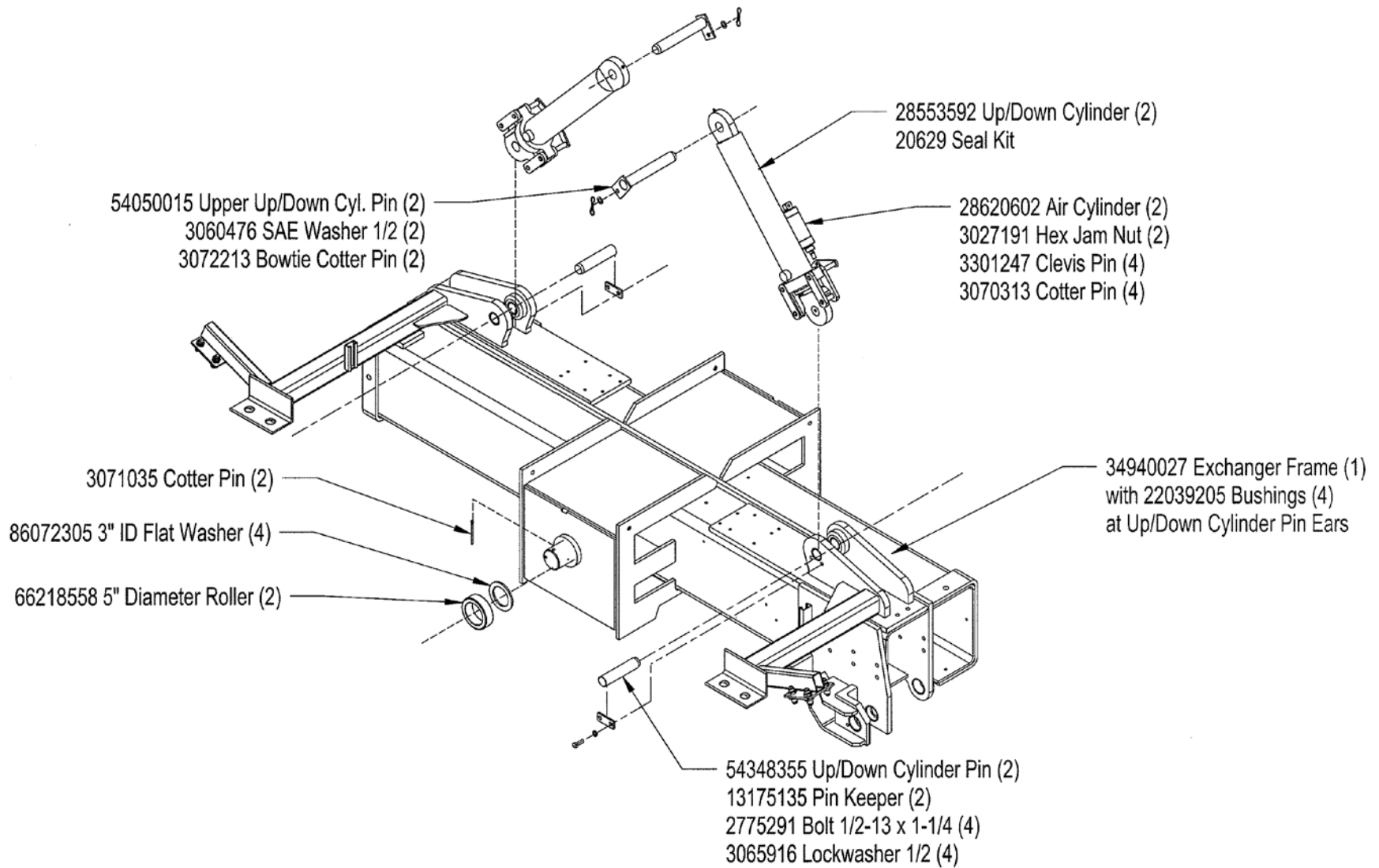

FIGURE 13B-1A. TIE EXCHANGER MAIN FRAME

S/N 760355 and Above

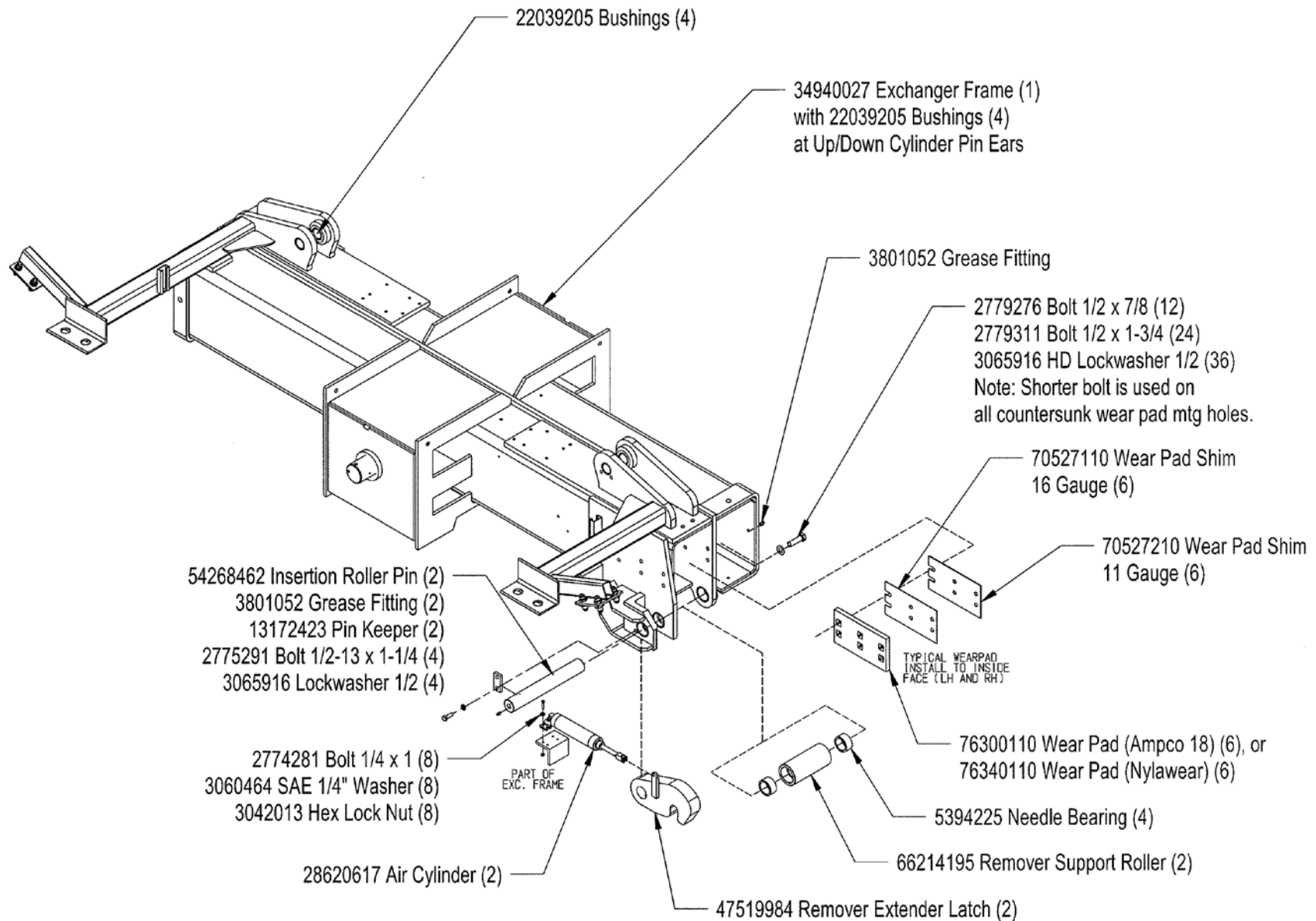

FIGURE 13B-1A. TIE EXCHANGER MAIN FRAME S/N 760355 and Above

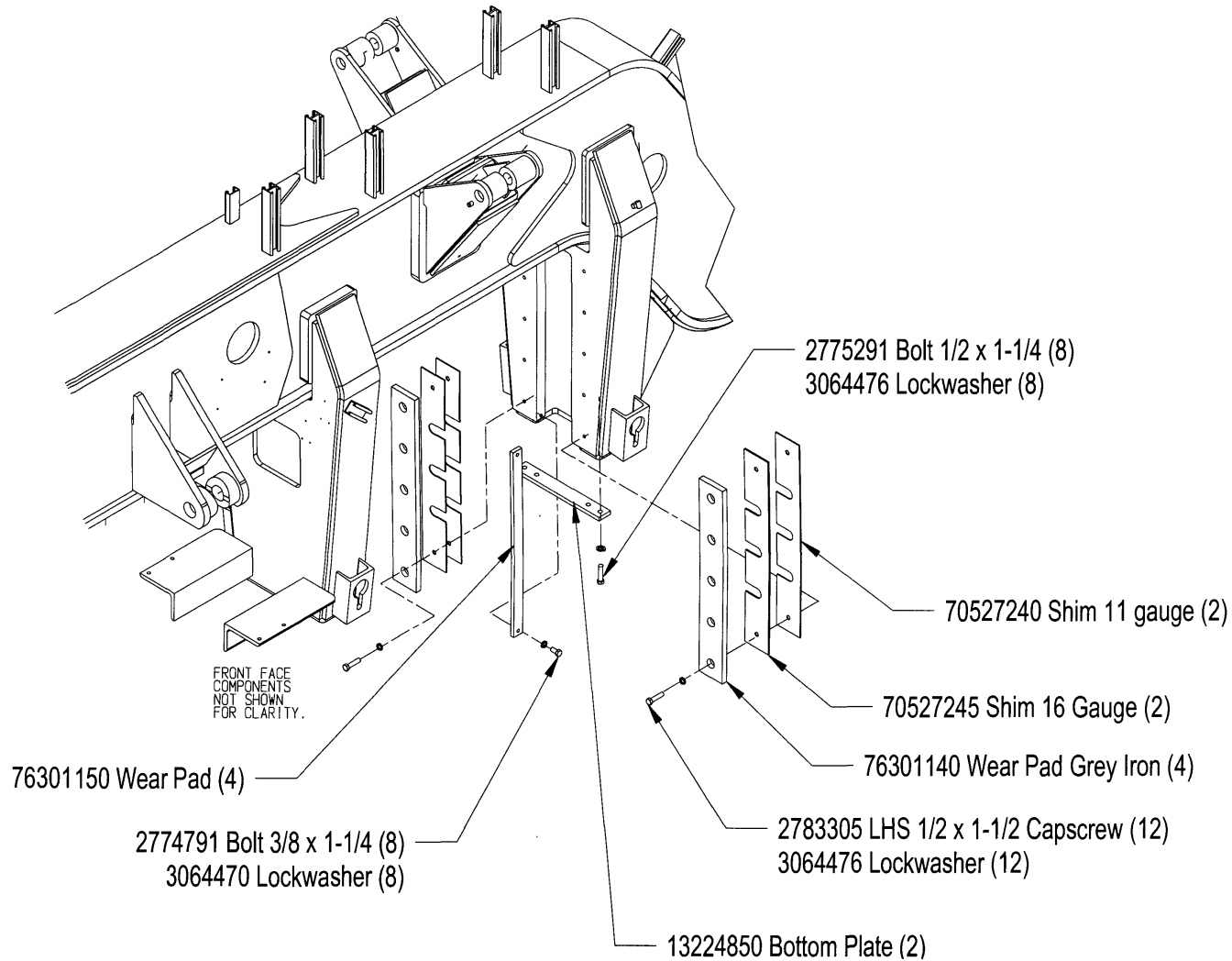

FIGURE 13B-1-1A. TIE EXCHANGER EXTENSION BOOMS

S/N's 760343, 760344, and 760348 and Above

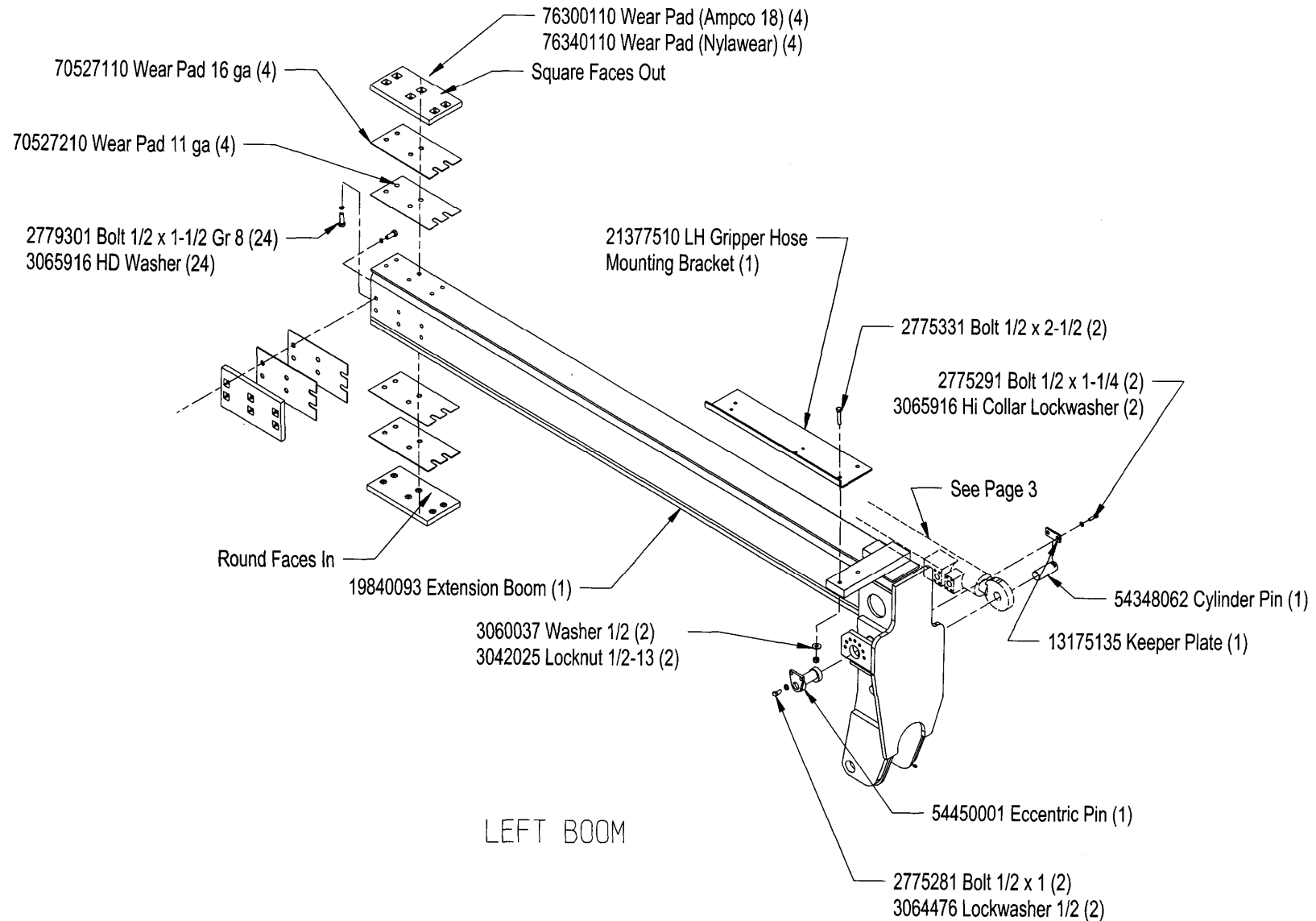
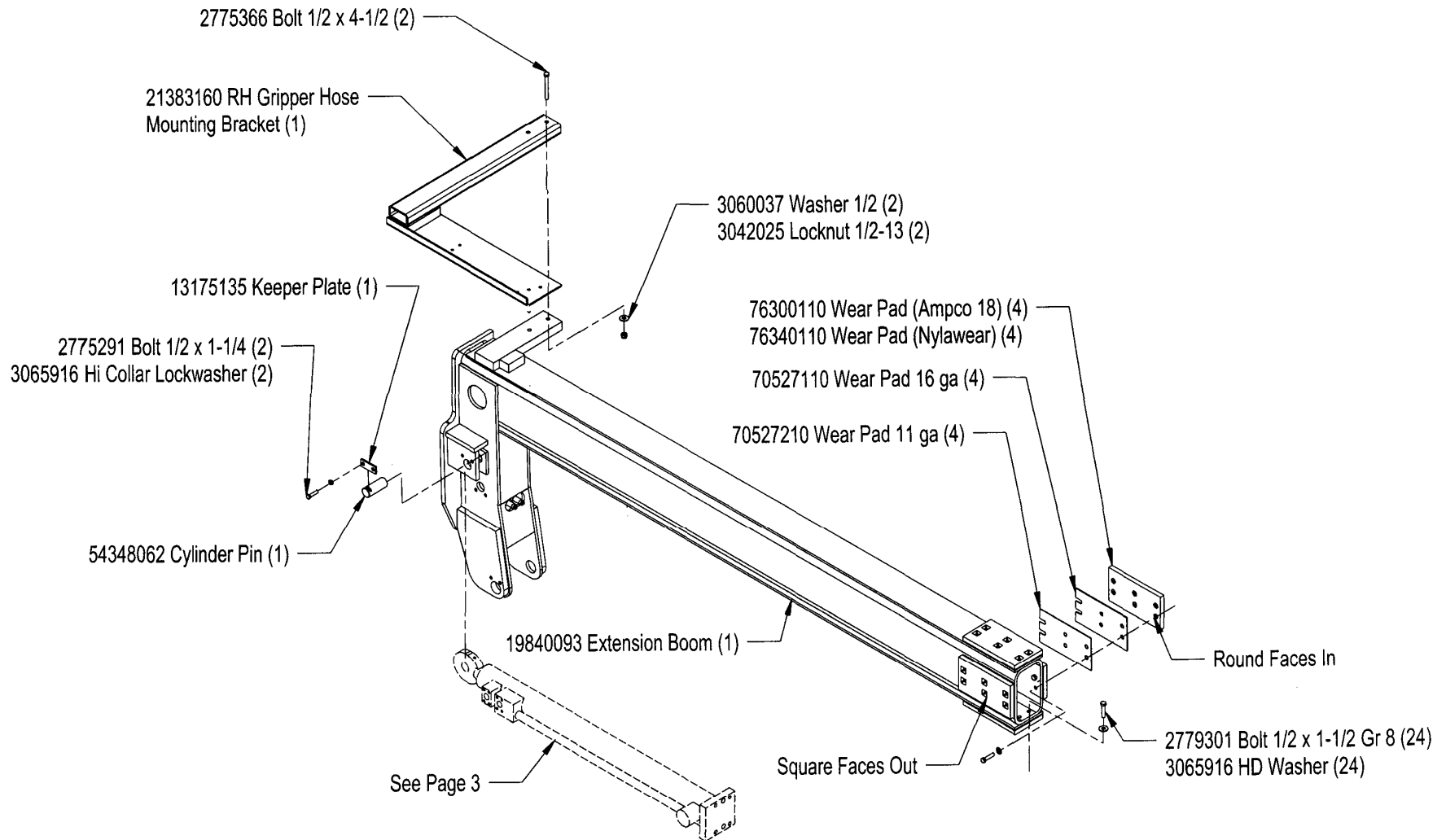

FIGURE 13B-1-1A. TIE EXCHANGER EXTENSION BOOMS

S/N's 760343, 760344, and 760348 and Above



RIGHT BOOM

FIGURE 13B-1-1A. TIE EXCHANGER EXTENSION BOOMS

S/N's 760343, 760344, and 760348 and Above

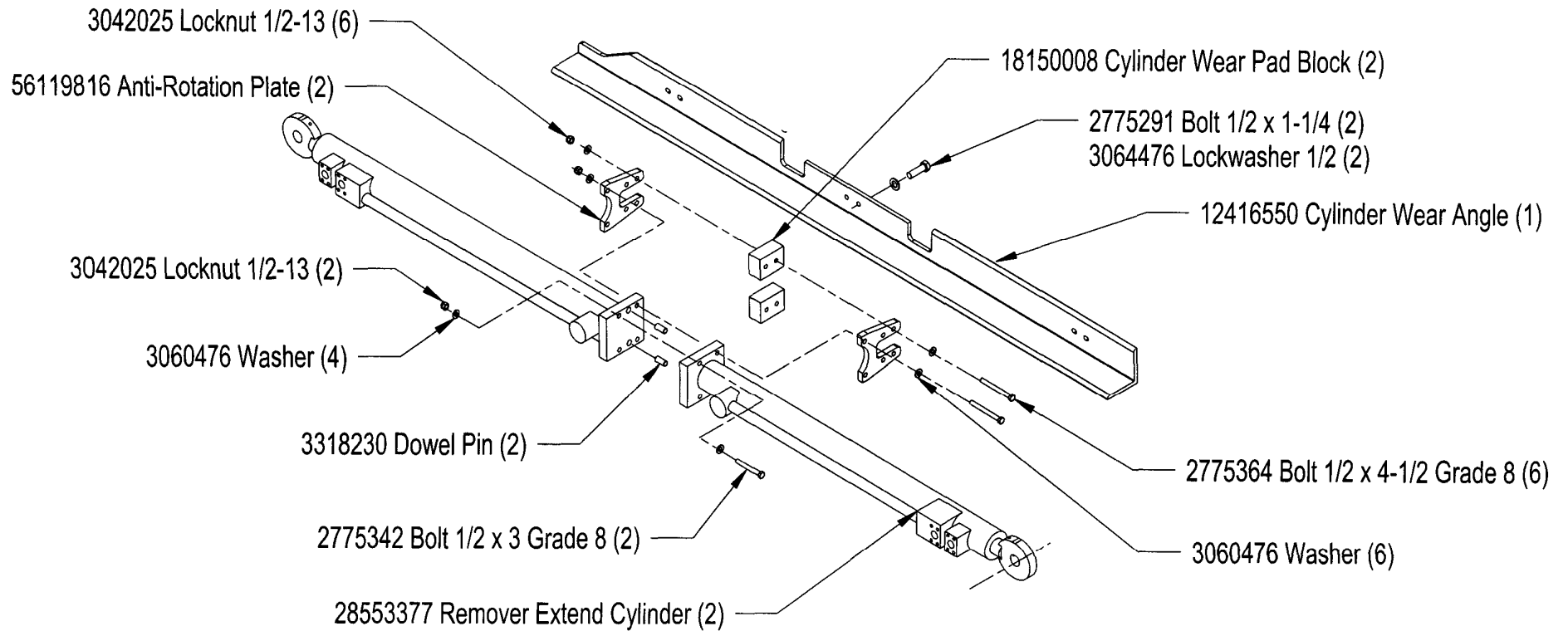

FIGURE 13B-1-1A. TIE EXCHANGER EXTENSION BOOMS

S/N's 760343, 760344, and 760348 and Above

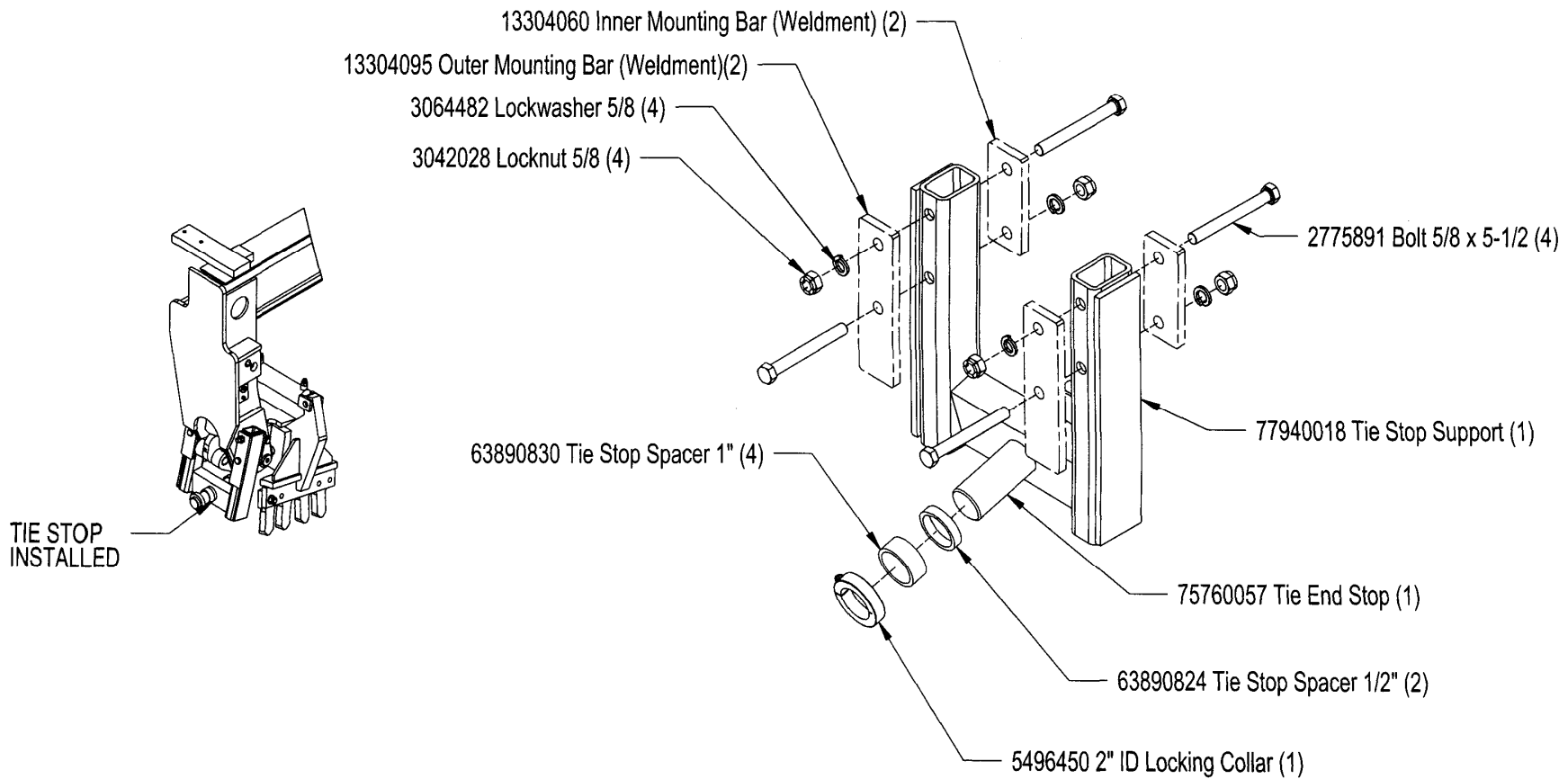
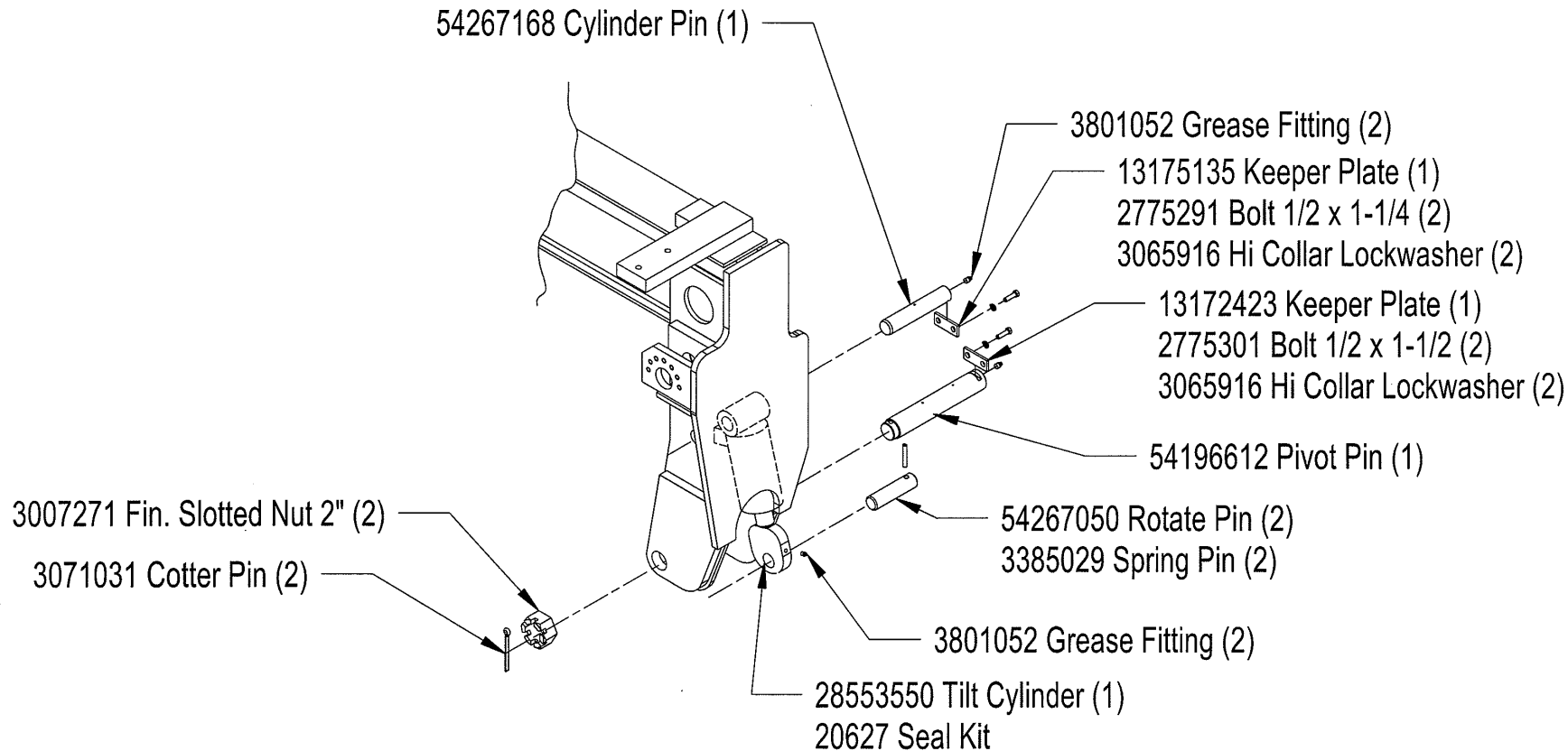

FIGURE 13B-2-1B. TIE EXCHANGER
63" WIDE GAUGE GRIPPERS
 S/N's 760419 and 760420 ONLY



Gripper Mounting

FIGURE 13B-2-1B. TIE EXCHANGER
63" WIDE GAUGE GRIPPERS
 S/N's 760419 and 760420 ONLY

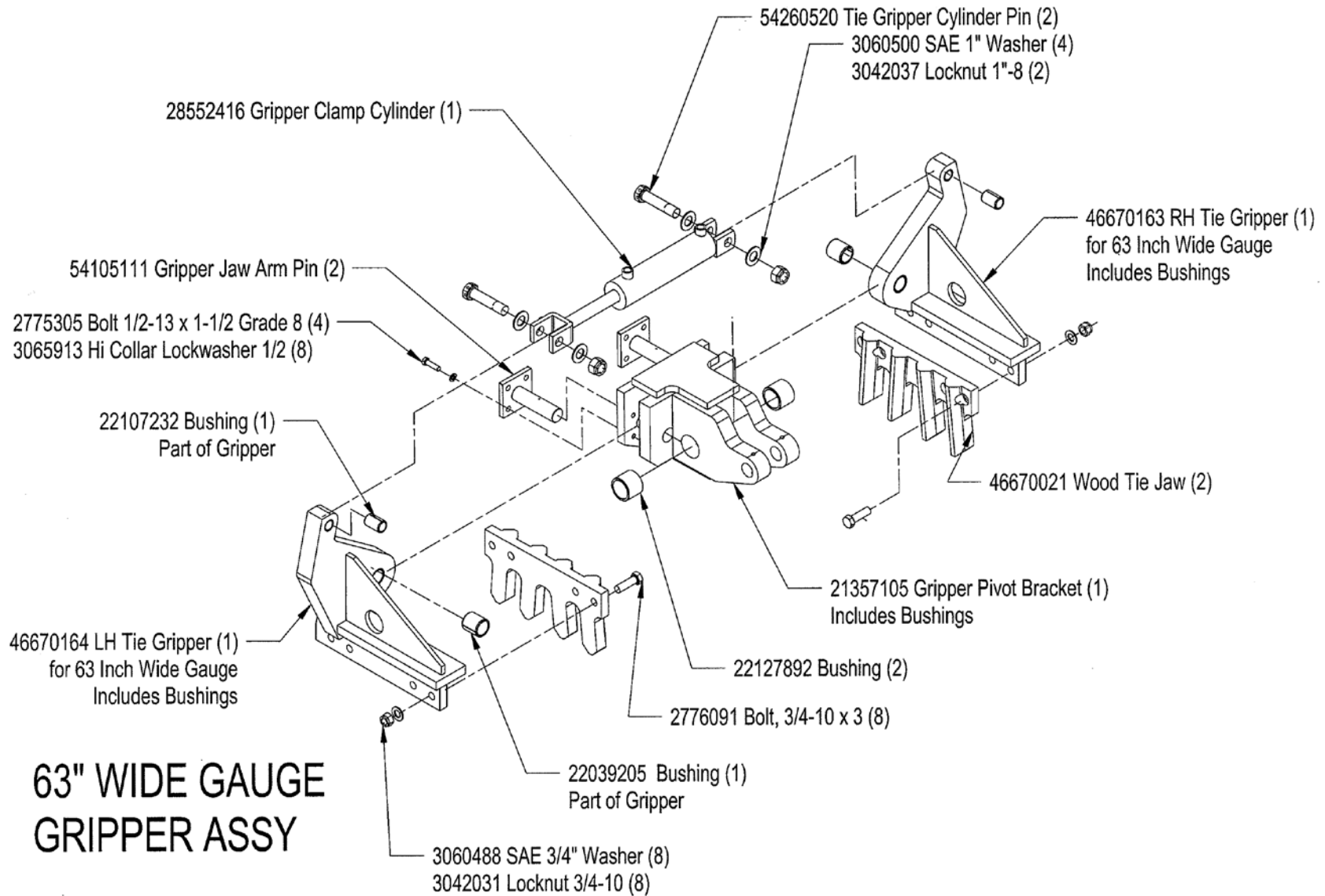
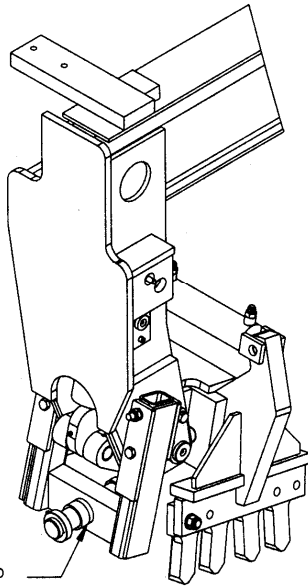
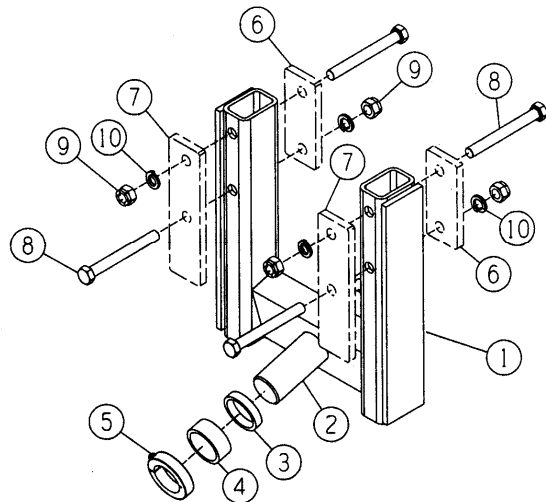

FIGURE 13A-1-2. TIE EXCHANGER
 Tie Insertion Stop (Optional)
 S/N 760163 and Above



TIE STOP
 INSTALLED



ITEM NO.	PART NO.	DESCRIPTION	UNITS PER ASSEMBLY
--	98760036	Tie Insertion Stop Kit	1
1	77940018	Tie Stop Support	2
2	75760057	Tie End Stop	2
3	63890824	Tie End Stop Spacer (1/2" Thick).....	4
4	63890830	Tie End Stop Spacer (1" Thick).....	8
5	5496450	2" ID Locking Collar	2
6	13304060	Inner Mounting Bar (Weldment).....	4
7	13304095	Outer Mounting Bar (Weldment).....	4
8	2775891	HH Capscrew 5/8 x 5-1/2.....	8
9	3042028	Hex Locknut, 5/8-11	8
10	3064482	Lockwasher, 5/8.....	8

**FIGURE 14A-1-1. RAIL CLAMPS
STABILIZER ONLY
S/N 760163 and Above**

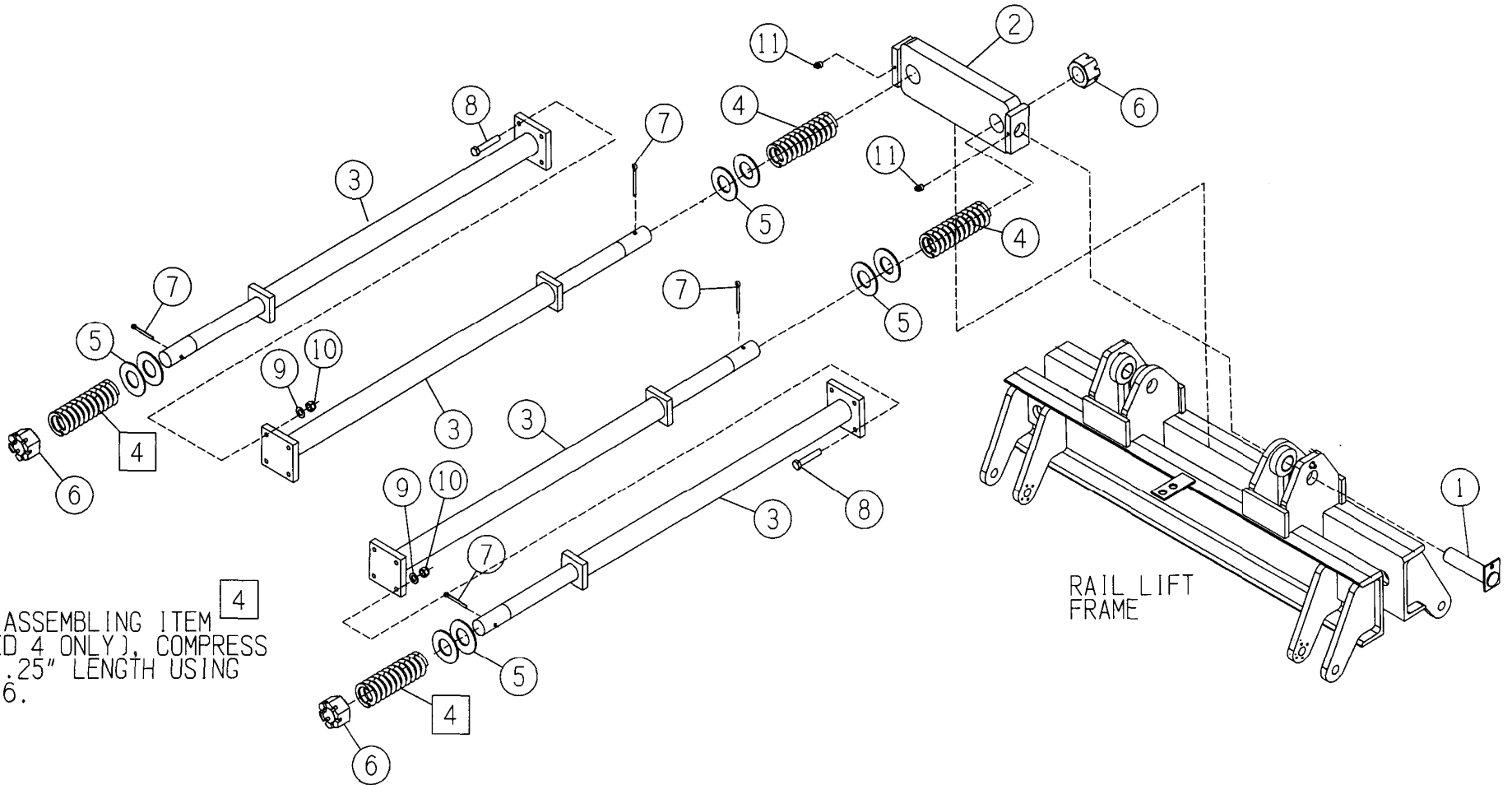

WHEN ASSEMBLING ITEM 4 (BOXED 4 ONLY), COMPRESS TO 11.25" LENGTH USING ITEM 6.

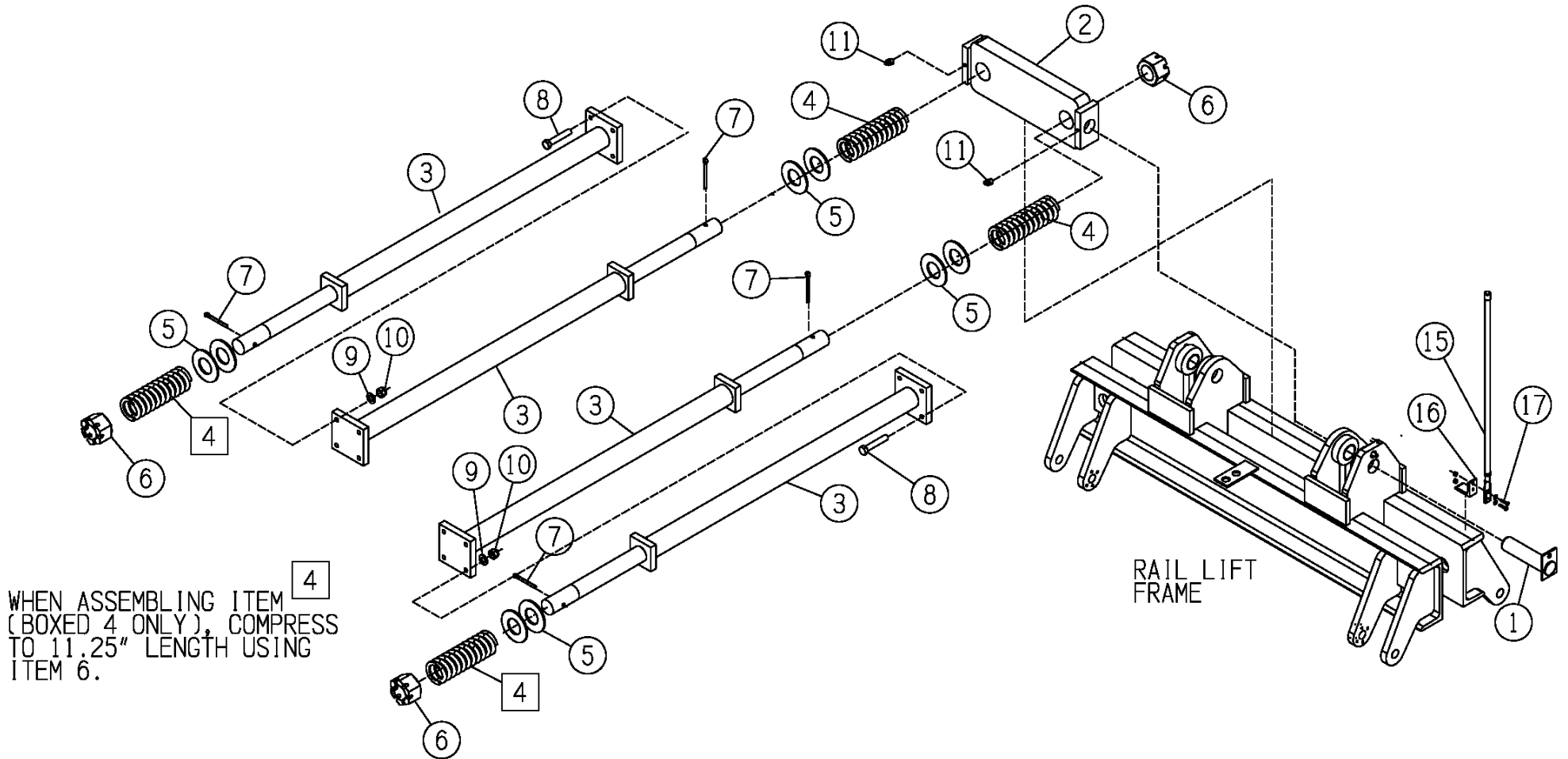

**FIGURE 14A-1-1. RAIL CLAMPS
STABILIZER ONLY
S/N 760163 and Above**

ITEM NO.	PART NO.	DESCRIPTION	UNITS PER MACHINE
1	54050080	Clamp Frame Lift Cylinder Pin	2
2	78490037	Stabilizer Support.....	1
3	78490038	Rail Lift Stabilizer Support.....	4
4	3622853	Compression Spring.....	4
5	3060095	Wrought Washer 2-1/4	8
6	51737800	Hex Nut 2-1/2 – 12	4
7	3071035	Cotter Pin 3/8 x 4	4
8	2775341	HH Capscrew, 1/2 x 3	8
9	3060476	SAE Washer 1/2.....	8
10	3042025	Hex Locknut 1/2-13	8
11	3801052	Grease Fitting.....	2

Refer to 14-1-2 for Stabilizer with Spotting Option.

FIGURE 14A-1-2. RAIL CLAMPS
STABILIZER With SPOTTING OPTION
S/N 760163 and Above



**FIGURE 14A-1-2. RAIL CLAMPS
STABILIZER With SPOTTING OPTION
S/N 760163 and Above**

ITEM NO.	PART NO.	DESCRIPTION	UNITS PER MACHINE
1	54050080	Clamp Frame Lift Cylinder Pin	2
2	78490037	Stabilizer Support	1
3	78490038	Rail Lift Stabilizer Support	2
4	3622853	Compression Spring	4
5	3060095	Wrought Washer 2-1/4	4
6	51737800	Hex Nut 2-1/2 – 12	2
7	3071035	Cotter Pin 3/8 x 4	4
8	2775341	HH Capscrew, 1/2 x 3	8
9	3060476	SAE Washer 1/2	8
10	3042025	Hex Locknut 1/2-13	8
11	3801052	Grease Fitting	2
12	28553551	Rail Lift Spotting Cylinder	2
13	5127383	Proximty Switch	2
14*	22311601-096	Prox Switch Cable	2
--	98760136	Rail Lift Frame Guide Kit	Option
15	12369740	Guide Mounting Angle	2
16	39120036	Rail Lift Frame Guide	2
17	2774291	Bolt 1/4-20 x 1-1/4	4
--	3060464	SAE Washer 1/4	4
--	3042013	Locknut 1/4	4

**FIGURE 14A-2-2. NON-INSULATED RAIL CLAMPS
GUIDE ROLLERS
Standard S/N 760163 and Above
BNSF S/N 760163-760337**

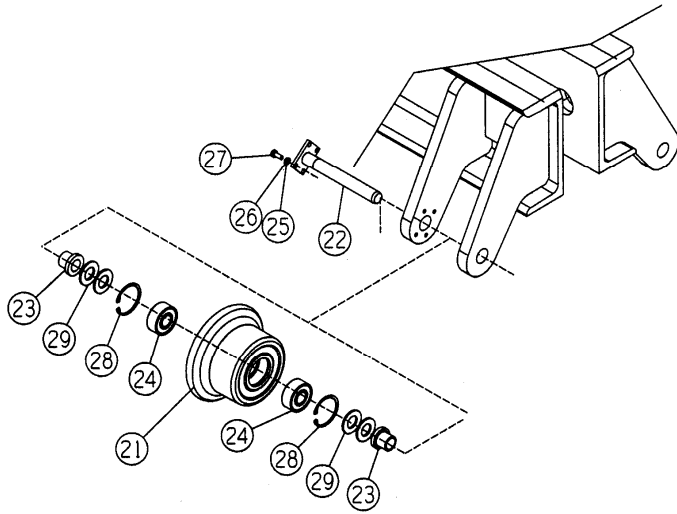

NON-INSULATED

ITEM NO.	PART NO.	DESCRIPTION	UNITS PER MACHINE
----------	----------	-------------	-------------------

Non-Insulated Guide Rollers

21	86963355	Wheel	4
22	54261725	Wheel Axle (Non-Insulated)	4
23	22103265	Axle Bushing (Non-Insulated).....	8
24	5371725	Roller Bearing.....	8
25	3060467	SAE Washer 5/16.....	16
26	3064467	Lockwasher 5/16	16
27	2774521	HH Capscrew 5/16 x 3/4	16
28	5405244	Retaining Ring.....	4
29	3060500	SAE Washer 1".....	8

Kits Available:

⊕	98760029	Rail Clamp Wheel Kit (Non-Ins.) Includes items 22-29
---	----------	---

FIGURE 14B-3A. RAIL CLAMPS
63 INCH WIDE GAUGE RAIL CLAMP ASSEMBLY
S/N 760419-760420 ONLY

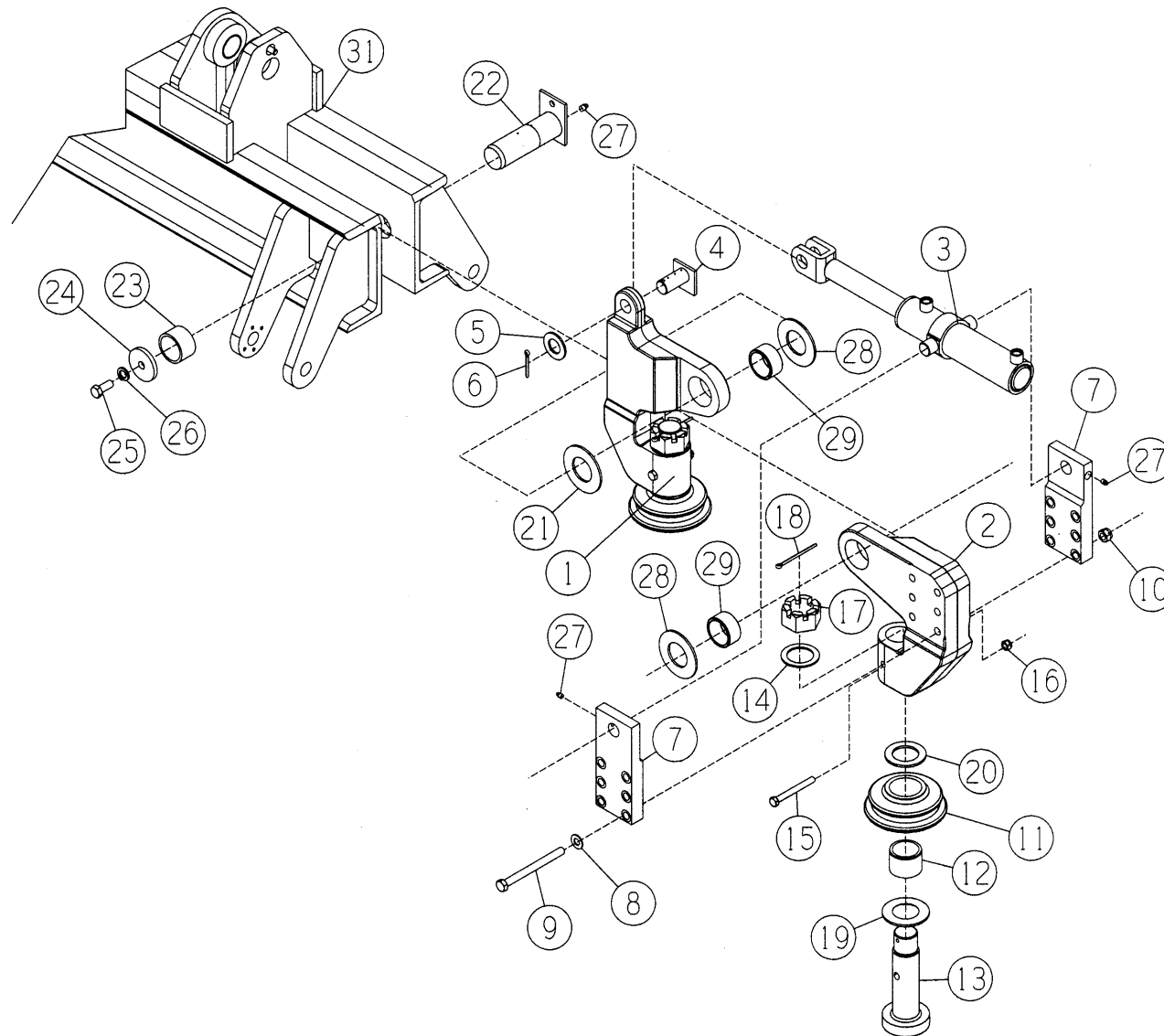

FIGURE 14B-3A. RAIL CLAMPS 63 INCH WIDE GAUGE RAIL CLAMP ASSEMBLY S/N 760419-760420 ONLY

ITEM NO.	PART NO.	DESCRIPTION	UNITS PER MACHINE
1	47736170	Clamp Lever.....	2
2	47736175	Clamp Lever (Trunion End).....	2
3	28552383	Clamp Cylinder.....	2
--	21201	Seal Kit.....	1
4	54105075	Clamp Cylinder Pivot Pin	2
5	3060512	SAE Washer 1-1/4	2
6	3070855	Cotter Pin	2
7	21385520	Rail Clamp Mounting Bracket	4
8	3060482	SAE Washer, 5/8	24
9	2775915	HH Capscrew, 5/8-11 x 7 (Grade 8)	12
10	3042028	Hex Locknut, 5/8-11	12
11□	66218544	Clamp Roller	4
12□	22130485	Clamp Roller Bushing	2
13□■	19552002	Rail Lift Roller Pin.....	4
14□■	86067980	Roller Pin Washer	4
15	2775371	HH Capscrew, 1/2 x 4-1/2.....	4
16	3042025	Hex Locknut, 1/2-13.....	4
17□■	3007271	Finished Slotted Nut 2-12 UNC.....	4
18□■	3070871	Cotter Pin, 1/4 x 4	4
19□■	86108778	Clamp Roller Washer.....	4
20□■	86108760	Clamp Roller Washer.....	4
21□■	86108785	Clamp Lever Spacer	2
22●	54050096	Rail Clamp Pin	2
23●	63892090	Spacing Ring.....	2
24●	86041342	Pin Retainer	2
25●	2775801	HH Capscrew, 5/8 x 1-1/2.....	2
26●	3064482	Lockwasher, 5/8.....	2
27●	3801052	Grease Fitting.....	6
28□■	86108781	Clamp Lever Frame Spacer.....	4
29A□■	22130472	Lever Pivot Bushing (Non-Insulated)	4
29B	22130475	Lever Pivot Bushing (Insulated)	4
31	33707602	63-Inch Gauge Rail Lift Frame (Ref. Only)	1

Kits Available:

ITEM NO.	PART NO.	DESCRIPTION	UNITS PER MACHINE
□	98760031	Kit, Rail Clamp Lever Bushing.....	2 Kits
■	98760032	Kit, Rail Clamp Lever Bushing.....	2 Kits
●	98760024	Kit, Pivot Pin Field Replacement.....	2 Kits

**FIGURE 14B-4C. RAIL CLAMPS
LIFT CYLINDER
S/N 760419 and 760420 ONLY**

