



Product Support Bulletin 2017-001

245 W. Forest Hill Avenue
Oak Creek, WI 53154

Contact: Technical Support, Phone: 800-445-9258 or Email: TechSupport@Nordco.com

Maintenance of Way ~ Work Equipment Bulletin

DATE: May 25, 2017

SUBJECT: HSTX Fuel Tank Mounting Ears on Main Frame

RATING:

<input type="checkbox"/> DIRECTIVE (Action is required)	<input checked="" type="checkbox"/> ALERT (Potential Problem)
<input type="checkbox"/> INFORMATION (Action is optional)	<input type="checkbox"/> PRODUCT IMPROVEMENT (Enhance Product)

MACHINE MODEL(S): Hydraulic Switch Tamper – HSTX series

SERIAL NUMBER(S): 220100 through 220201

SUMMARY: In some instances the mounting brackets/ears welded to the horizontal flat bars extending off the machine frame for mounting of the fuel tank, may not have sufficient weld at the required location.

OPERATIONAL IMPACT: Due to the lack of weld the fuel tank and tank straps may become separated from the frame.

ACTION: It is required to inspect the welding on the bracket/ear for the correct specification. If weld is not correct, it will be necessary to weld the frame brackets to the correct OEM specifications. The upper and lower brackets/ears will require a full 1/4" weld on the back side where it attaches to the horizontal flat bars extending off the machine frame. This may require removing the fuel tank to gain sufficient access for inspection and repair. Any old or incorrect welds will need to be ground off and the area prepared properly for the new weld. The diagrams below will provide the correct specifications. *The installation bolt specifications are noted below as well.

WARRANTY: None

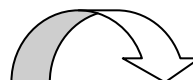

NORDCO Product Support Bulletin 2017-001

Diagram #1

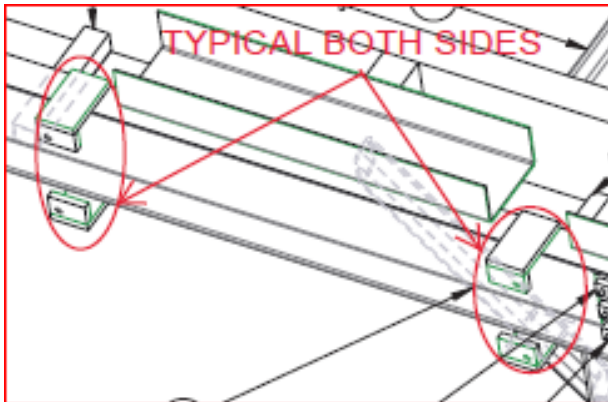
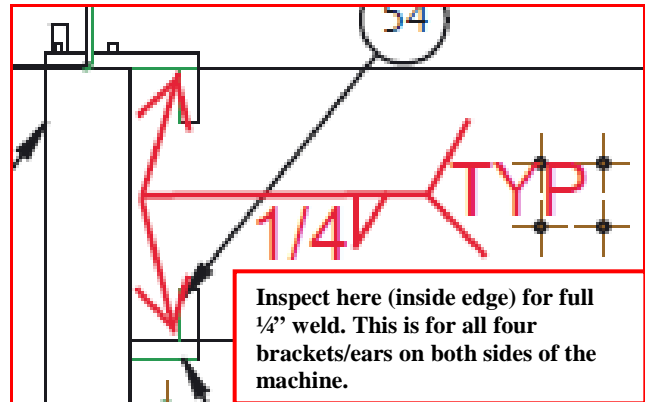

Diagram #2



*The required mounting bolts are a Grade 5 Hex Head (1/2" x 1-1/2") p/n 2775301. They should be installed with Threadlocker 242 (Blue) and torqued to 60-65ft-lbs, along with a (1/2") heavy duty lock washer p/n 3060477 and a (1/2") hardened flat washer.