



# M7 Model A Ballast Regulator Snow FIGHTER



## Operation and Maintenance Manual

For S/N 800500 and Above  
Reorder Part: 49458002  
Last Revision: C  
FEBRUARY 2011

Read and fully understand the precautions contained in this manual before operating or servicing this machine. Refer to Section 1 for important safety information.

Component Troubleshooting can now be found on the blue pages behind each tab.



This manual is a guide for the operation and routine maintenance of a NORDCO Railroad Maintenance Machine. It covers product technical information, basic operating and maintenance procedures, and safety information and is provided for use by the qualified personnel who will supervise, operate or service the equipment described herein.

Measurements in this manual are given in both metric and customary U.S. unit equivalents.

Personnel responsible for the operation and maintenance of this equipment should thoroughly study the manual before commencing operation or maintenance procedures.



This manual should be considered a permanent part of your machine and should remain with the machine at all times.

Additional copies of this manual are available either as a part (Operation Manual only) or a whole (operation and parts manual), at a nominal cost, through our Part Sales Department. Additional service information, parts, and application information is available through these Nordco product support resources:

NORDCO Sales:

**Milwaukee, Wisconsin**  
(414) 766-2180  
[sales@nordco.com](mailto:sales@nordco.com)

NORDCO Parts:



**Milwaukee, Wisconsin**  
1-800-647-1724  
[parts@nordco.com](mailto:parts@nordco.com)

NORDCO Service:

1-800-445-9258  
[service@nordco.com](mailto:service@nordco.com)

We ask that if you have any comments or suggestions about this manual, let us hear from you. We are here to be of service to you, our customers. Direct your comments and inquiries to:



Technical Documentation Department  
NORDCO Inc.  
245 W. Forest Hill Avenue  
Oak Creek, WI 53154

## HAZARDOUS MATERIAL DATA

In an effort to provide information necessary for your employee safety training program and to meet the requirements of OSHA Hazard Communication Standard 1910.1200, we have OSHA Form 20 Safety Data Sheets available that cover the material contained in this machine.

If you are interested in receiving this information, please refer to the Name, model, and Serial Number of your machine when calling or writing, and direct your inquiries to:



Vice-President of Operations  
NORDCO Inc.  
245 W. Forest Hill Avenue  
Oak Creek, WI 53154

Fax: (414) 766-2299  
Phone: (414) 766-2249

**SAFETY**

Please read and comply with all of the safety precautions in this manual BEFORE operating this machine.

**GENERAL**

**DO NOT** use this machine for machine operations other than for which it was intended.

NORDCO is not responsible for any modifications made without authorization or written approval. Replace all NORDCO and OEM parts with genuine NORDCO or OEM parts. Use of non-OEM parts could compromise the safety of your machine.

FRA regulations require that a copy of this Operation Manual be kept on the machine at all times. Additional copies of the Operation Manual only can be ordered from Nordco Parts Sales at 1-800-647-1724.

**FOLLOW SAFETY INSTRUCTIONS**

Carefully read all safety messages in this manual. Learn how to operate the machine and how to use controls properly. Do not let anyone operate this machine without instruction. Failure to understand the contents of this manual could result in serious personal injury or death.

**SAFETY ALERT SYMBOLS!**

These are the safety-alert symbols.  
These symbols means pay attention! Your safety is at risk!



**DANGER** is used to indicate a definite hazardous situation which, if not avoided, **WILL** result in severe bodily harm or even death.



**WARNING** indicates a potentially hazardous situation which, if not avoided, **COULD** result in severe bodily harm or even death.



**CAUTION** indicates a potentially hazardous situation which, if not avoided, **MAY** result in minor or moderate injury.



**Formerly CAUTION** without the safety “!” means that failure to follow the alert may result in machine damage.



**SAFETY** means that the following points are instructions for safely operating the machine or the specific component of the machine.

### GENERAL SAFETY TIPS

Only trained and authorized personnel should be allowed to operate this machine. In addition, all personnel at the worksite (gang) should be aware of the safety concerns and their individual responsibilities **prior to working this machine.**

### SAFETY

1. Handle fuel safely. It is highly flammable and prolonged breathing of fumes may cause bodily harm.
2. Prepare for emergencies. Keep a first aid kit and fire extinguisher handy.
3. Protect against flying pieces of metal and debris by wearing safety glasses or goggles.
4. Wear good-fitting pants and shirt, no baggy or loose clothing.
5. Protect your head and eyes from flying debris by wearing a hard hat and safety goggles/glasses.
6. Wear leather gloves to protect your hands from vibration or flying metal particles.
7. Use safety-toed work boots.

### SAFETY PRIOR TO WORKING

All personnel at the worksite (gang) should be aware of the safety concerns and their individual responsibilities **prior to working this machine:**

### SAFETY

- Review the operating instructions if you are unsure of anything.
- Use the “pre-operational checklist” to check the machine for obvious faults. Repair or replace as necessary **PRIOR** to operating the machine.
- Before climbing onto the machine, make certain the area around and

under the machine is clear of obstructions and personnel.

- Use care when climbing onto the machine. Always use the steps and handrails provided. (If an area does not have tread grips, walkways, or other methods to access the area, then **DO NOT** attempt to access that area.)
- Make seat and control adjustments **PRIOR** to starting the machine. **ALWAYS** wear a seatbelt.
- Know the weather forecast and plan your work speeds accordingly.
- There are guards on this machine. These are to be removed **ONLY** when service or maintenance is being performed on that area of the machine. Make certain they have been re-installed **PRIOR** to starting the machine.
- Check and service the fire extinguisher (if so provided) at regular intervals. Make certain all personnel are trained in its use. Note - Non-use of fire extinguisher still requires that it be recharged at the interval stated on its last inspection notice.
- Keep the stairs, cab entry platform and cab interior free and clear of ice, tools and personal items. Use the accessories provided on the machine (tool box, cup holder, coat hook, etc.) to properly store your gear.
- Never climb onto the machine while it is in motion.
- There are lockups on this machine that are used for both work and travel. These should be kept clear and free of debris, grease, etc. See **Lockup** section for instructions on their use.
- Inspect safety decals and replace when they become unreadable or are damaged. (See “Safety Decals” at the end of this Safety section).

**SAFETY WHILE STARTING THE MACHINE**

NORDCO recommends the use of a **Command** position. This means that the machine is **never** running unless someone is **at or near** the main control panel or remote control boxes. To prevent injury to personnel or damage to the machine, it is highly recommended to:

**SAFETY**

1. Only start and operate the machine from the front operator's seat.
2. Use the "STARTUP Checklist" to check the machine controls and gauges to make certain all systems are operating correctly.

**SAFETY WHILE OPERATING/TRAVELING****SAFETY**

1. Never allow more riders than seats and seatbelts allow. This machine was designed to be operated by one or two persons with optional third rider.
2. The machine is to be operated from the Operator's seat only. Do NOT stand and operate this machine.
3. Press the EMERGENCY STOP pushbutton on the center control console in emergencies and potentially dangerous situations.
4. If personnel or bystanders are near the machine during operation, give a warning signal using the horn. If they fail to respond to this warning, stop operation immediately.
5. Slow down the work cycle and use slower travel speeds in congested or populated areas.
6. Halt work if visibility is poor. Strong rains, fog, and extremely dusty conditions can affect visibility in your work area. Wait for the weather to improve before continuing work.

**SAFETY WHILE PARKED**

When leaving a machine engine running, make certain that the parking brake/electrical interlock button has been activated.

NEVER stop and park this machine on an incline unless the machine wheels have been chocked.

**SAFETY DURING MAINTENANCE**

The following guidelines are suggested when performing maintenance:

**SAFETY**

1. Always chock the wheels
2. Alert others in the area that service or maintenance is being performed on this machine.
3. Become familiar with, and use, **your company's lockout/tagout** procedures when performing maintenance on this machine. See **LOCKOUT/TAGOUT REQUIREMENTS** later in this Safety Section for a chart on energy sources located on this machine.
4. Do not start the engine if repairs or work is being performed alone. You should always have at least two people working together if the engine must be run during service. One person needs to remain in the **command** position (at the controls), ready to stop the machine and shut off engine if the need arises.
5. Collect oils and fuels and dispose of them properly. There is a danger of scalding when working with engine oils.
6. Use only Nordco supplied repair parts for this machine. Use of non-OEM designed parts could compromise the integrity of this machine.
7. There are welding cautions on this machine. Pay attention to them PRIOR to welding.
8. Kits supplied by Nordco have welding instructions included. Welding of any components NOT of Nordco's manufacture or failure to follow these instructions may affect the stability of this machine.

**MACHINE SAFETY  
ALERTS**



**DANGER ALERTS**

<p>Improper use of this machine for any type of operation can cause serious injury or death.</p>
<p>To avoid serious injury or death, make certain that the area around and under the machine is clear of all personnel and obstructions BEFORE travelling or working.</p>
<p>Serious injury or death can result from reaching into working components while machine is running. Make all observations from a distance and SHUT OFF machine while making adjustments.</p>
<p>Shut off engine when checking battery electrolyte level. Do not check or fill battery in presence of open flame, sparks, or when smoking. Battery fumes are flammable and/or explosive and if ignited will result in severe bodily injury or death.</p>
<p>Do not ride on tow bar between the machine and the towing vehicle. Falling from a moving vehicle may cause serious injury or death.</p>

**MACHINE SAFETY  
ALERTS**



**WARNING ALERTS**

<p>Failure to engage all lockup devices before propelling at travel speed can result in injury to personnel and/or extensive damage to the machine.</p>
<p>Remove hoses/fittings only when system is not pressurized. High pressure leaks can cause personal injury.</p>
<p>Always turn off machine when performing maintenance, making adjustments, or whenever unintended movement of machine could occur; unless directed otherwise. Failure to comply could result in personal injury and/or damage to the machine.</p>
<p>Exhaust emissions caused by the use of the engine on this machine may cause cancer, birth defects, or other reproductive harm if inhaled.</p>
<p>Disconnect the battery before servicing this machine. Failure to do so could result in personal injury from accidental engine startup.</p>
<p>You must always use the foot switch or parking brake to stop this machine while in the Travel Mode. Failure to do so may cause personal injury or machine damage.</p>



**CAUTION! ALERTS**

Activating plow float while the plow is in the fully raised position will cause the plow to drop suddenly. This may cause personal injury and/or machine damage.

**NOTICES  
(Machine damage only)**

Before starting a new or overhauled engine that has been in storage, consult the engine manufacturer's manual for initial start instructions. Failure to follow those instructions can result in serious engine damage.

Never shut off the battery disconnect switch with the engine running. This could cause damage to the voltage regulator, alternator, and/or electrical system.

### LOCKOUT AND/OR TAGOUT REQUIREMENTS

The following list suggests lockout procedures to use on all components of the machine that require lockout due to the storage of various forms of energy. It is your company's responsibility to **Lockout/Tagout Procedures** based on this list, train you in their proper and safe use, and to periodically inspect your work area to verify that you are complying with the procedures. **Lockout/Tagout Procedures must be followed!**

NORDCO has provided the means to lockout this machine. NORDCO cannot be held responsible for injury caused by failure to comply with your company's **Lockout/Tagout Procedures**. See next page for suggested lockout/tagout procedure list.

## LOCKOUT-TAGOUT PROCEDURES

The following procedures are designed to lead the operator through the steps required to shut the machine down and prepare it for performing mechanical maintenance work. These procedures are intended to release potentially dangerous stored energy forms and make the machine safe to begin repairs.

**SAFETY PROCEDURES**  
**LOCKOUT/TAGOUT**

1. Apply parking brakes by pushing in **parking brake/electrical interlock button** located on the center (front) control console. Note: A high energy spring applies all four brakes.
2. Chock wheels to prevent accidental rolling of machine on grade.
3. If you have not already done so, determine which components are to have maintenance. Place all machine mechanical systems or workheads in the full up and locked positions.
4. Refer to the list on the next page to determine what procedures are required when mechanical locking up of equipment is not feasible for maintenance. Then continue on with Steps 5-9.
5. Turn the **ignition switch** to the **OFF** position. This turns off the power to the control circuits on the machine. Place a **TAGOUT card** in close proximity to the ignition switch.
6. Turn the **battery disconnect switch (BDS)** to the **OFF** position.
  - a. For machines with the BDS on the left side of the center (front) control console: Place a **TAGOUT card** on the switch after you have switched it to the OFF position.
  - b. For machines with a remotely located BDS (usually next to the battery box itself): Close the cover to the disconnect switch and place a **LOCKOUT lock** on the box after you have switched it to the OFF position.
7. Bleed off hydraulic pressure.
8. Follow all of your company's lockout/tagout rules before proceeding. Note: When working on machine components, be aware that moving components during repairs may create energy (ie., moving a hydraulic cylinder). Proper precautions should be taken.

# SAFETY

## M7 Model B Ballast Regulator & Snow Fighting Machine

This list is for specific components in an assembly, where maintenance cannot be performed with the assembly in the full up and/or locked position. After completing the steps required, continue on with Steps 5-8 on the previous page.

<b>When performing maintenance on:</b>	<b>Secure as follows:</b>
<b>FRONT PLOW ASSEMBLY</b>	
Plow Up/Down Cylinder	Lower plow until it rests on solid ground.
<b>BALLAST WING ASSEMBLY</b>	
	Lower wing(s) until on solid ground.
<b>SNOW WING ASSEMBLY</b>	
	Lower wing(s) until on solid ground.
<b>BROOM ASSEMBLY</b>	
Broom Housing	Raise broom. Lock the broom in the UP position by pressing the power lockup button on the control panel. Tilt broom up and lock in place with lock chains.
Broom Up/Down Cylinder	Lower broom to rail.
<b>SNOW SCREW &amp; BLOWER ASSEMBLY</b>	
Broom Housing	Raise broom. Lock the broom in the UP position by pressing the power lockup button on the control panel. Tilt broom up and lock in place with lock chains.
Broom Up/Down Cylinder	Lower broom to rail.

**SAFETY ALERT DECALS ON THIS MACHINE**

Safety alert decals and plaques that have been placed on this machine are to be kept clean and legible. Replace any decals or plaques that have become illegible or are missing.

When repairing or replacing components that had safety decals on them, it is your responsibility to replace the safety decals. These can be ordered from the Parts Sales Department.

A complete list of decals and plaques on this machine can be found behind the Mechanical Tab at Figure 6.

### GENERAL

This manual contains operation and maintenance information for the **M7 Ballast Regulator & Snow Fighting Machine**, manufactured by NORDCO INC., Oak Creek, Wisconsin. Information regarding the operation and maintenance of this machine can be found behind the appropriate tabs. Information regarding operation and maintenance of OEM parts not of NORDCO manufacture can be found at the back of this manual, behind the tab marked **Component Data**.

Become familiar with all safety instructions, controls and instruments before operating this machine. Follow all instructions carefully.

#### ABOUT THIS MANUAL

This manual has been broken down into sections which have been separated by index tabs:

**Mechanical** has individual parts breakdown drawings and lists for each assembly

**Hydraulic** includes adjustment instructions and troubleshooting for the hydraulic system; and all piping and functional drawings for a standard machine and optional equipment

**Electrical**, includes all electrical schematics, logic box, control box, and cable drawings for the machine; and troubleshooting instructions

**Component Data** includes parts breakdowns and service instructions for components installed on the machine that are not of NORDCO's manufacture

**SPECIFICATIONS❖**

**GENERAL**

Gross Weight\* ..... 54,000 lbs (24,494 kg)  
 Length\* ..... 37 Feet (11.2 meters)  
 Width (With Wings in the Up and Locked Position) ..... 11 feet 4 Inches (3.44 meters)  
 Working Clearance (from center of track with one Fixed Wing Extended) ..... 14.1 feet (4.02 meters)  
 Height ..... 12 feet 6 inches (3.81 m)  
 Wheel Base ..... 15 feet (4.57 m)  
 Travel Speed On Rail ..... 40 mph (64 km/h)  
 Turntable ..... Hydraulically Operated – Rail to Rail  
 Towing Speed ..... 35 mph (56 km/h) max. (See Towing Procedure)

**CAPACITIES**

Fuel Tank (Painted Green) ..... 150 gallons (567 liters)  
 Hydraulic Oil Tank (Painted Blue) ..... 170 Gallons (643 liters)  
 Oil Cooler ..... 100 gpm (378 L/mn)

**ENGINE**

Make/Model ..... John Deere 6068HF485, Tier 3  
 Type ..... Turbocharged, 6-Cylinder  
 Continuous BHP ..... 275 BHP  
 Oil Capacity ..... 34 Quarts (32.5 liters)  
 Coolant Capacity ..... 13 Quarts (11.9 liters)

**HYDRAULIC SYSTEM**

Pressure Settings:  
 Relief Valve - Track Drive ..... 4640 psi  
 Relief Valve – Main Circuit ..... 2700 psi  
 Working Pressure ..... 2500 psi  
 Pumps:  
 Track Drive ..... Sauer Danfoss 90 Series, 100cc  
 Double:  
 Implement & Blower ..... Sauer Danfoss 45 Series, 130 cc  
 Broom ..... Gear, 44 gpm @ 2500 psi

**ELECTRICAL SYSTEM**

Battery ..... 24 Vdc (Dual 12V DC batteries), 1300 Cold Cranking Amps  
 Ground ..... Negative  
 Alternator ..... 90 Amp

**DRIVE SYSTEM**

Drive Type ..... Dual Axle Drive  
 Propulsion Type ..... Hydraulic Motor Driven  
 4-Speed Transmission

**AXLE/WHEELS**

Axle Size ..... 5-inch  
 Wheel Type ..... Forged Steel  
 Wheel Size ..... 24 inch ( 60 cm) diameter  
 Brake Type ..... Cobra Style

❖Items or capacities may vary according to options on your machine.

\* Approximate weight and length. Actual weight and length may vary according to options on your machine. Actual weight and length of your machine is as stenciled.

This sheet intentionally left blank



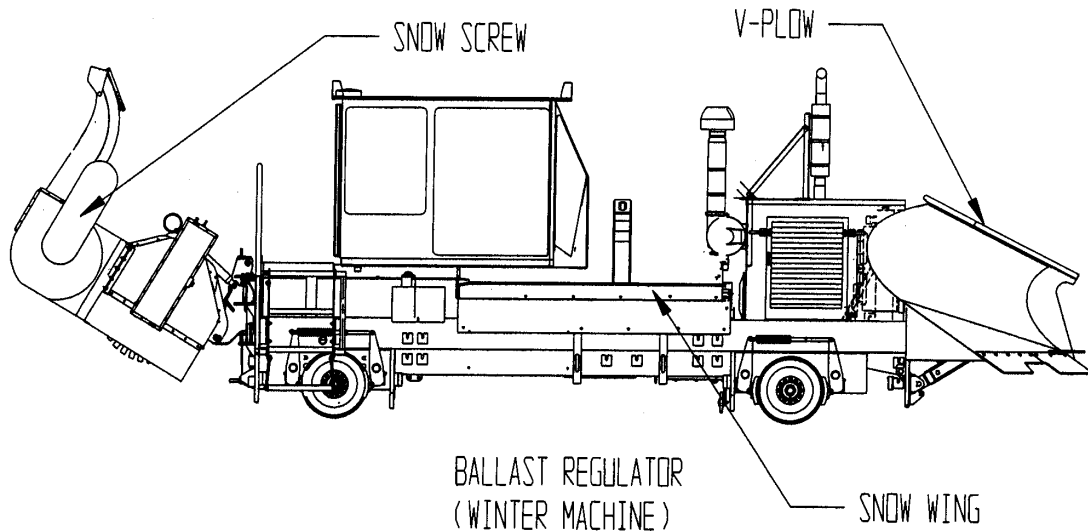
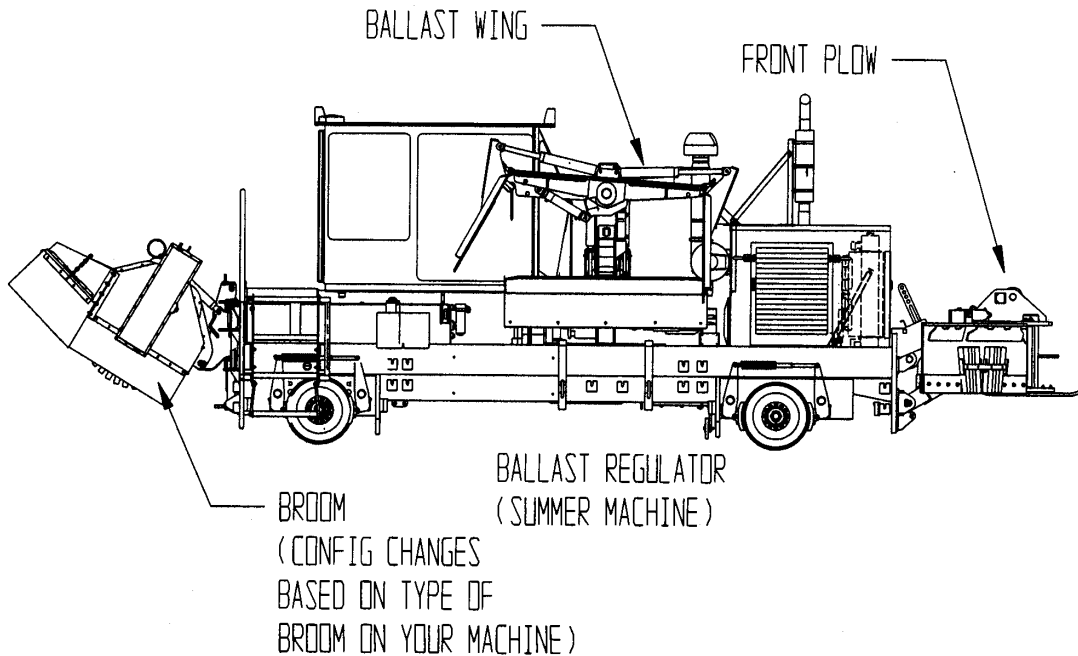
Before operating this machine, read and understand the Safety Section of this Manual.

BEFORE OPERATION



IMPROPER USE OF THIS MACHINE FOR ANY TYPE OF OPERATION CAN CAUSE SERIOUS INJURY OR DEATH.

It is always good practice to become totally familiar with the machines you are going to operate.



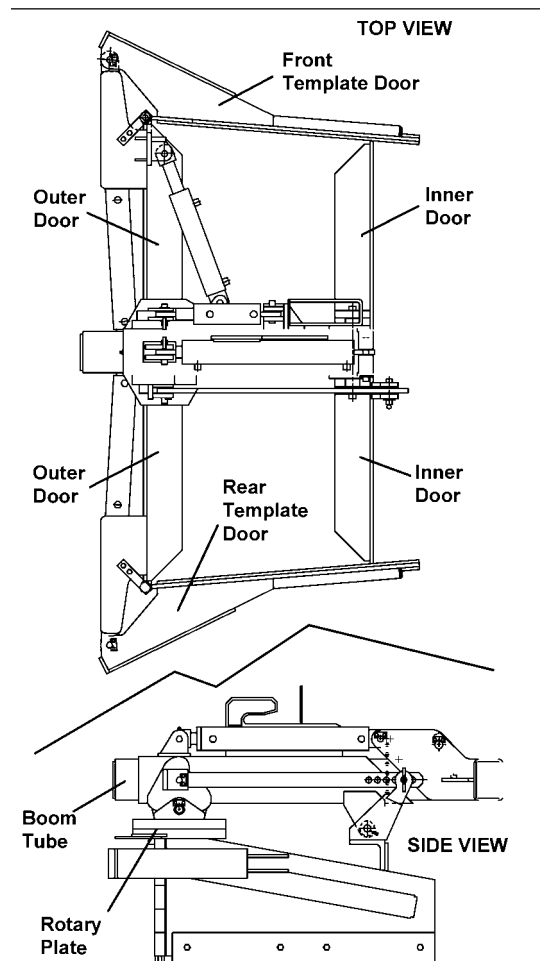
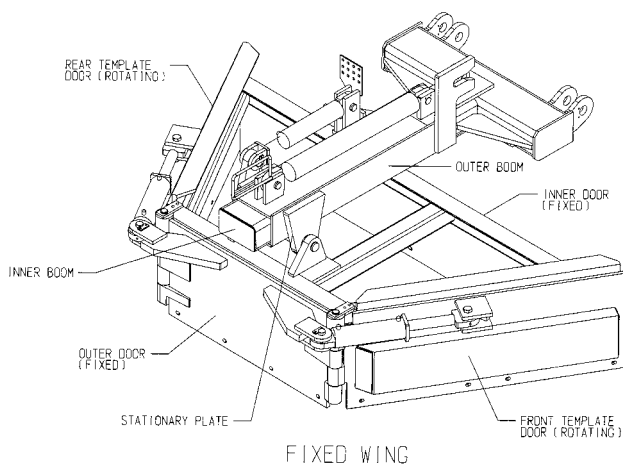
## BALLAST WING (SUMMER)

The ballast wing is designed to transfer ballast from one location to another. Method of transferring ballast depends on the type of wings you have installed on your machine. Nordco currently offers three different styles of ballast wings. Hand controller functions vary according to the style of wings installed on your machine.

### FIXED WINGS

Front and rear template doors can be extended (open) or retracted (closed).

The entire wing can be tilted to a 45° degree angle (either top in or top out)



### ARTICULATING ROTATIONAL WINGS

Front and rear template doors can be extended (open) or retracted (closed).

The entire wing can be tilted to a 45° degree angle (either top in or top out)

Inner doors can be tilted to about a 90° angle (either top in or top out)

Front and Rear Template Door angles can be adjusted to accommodate varying grades of ballast.

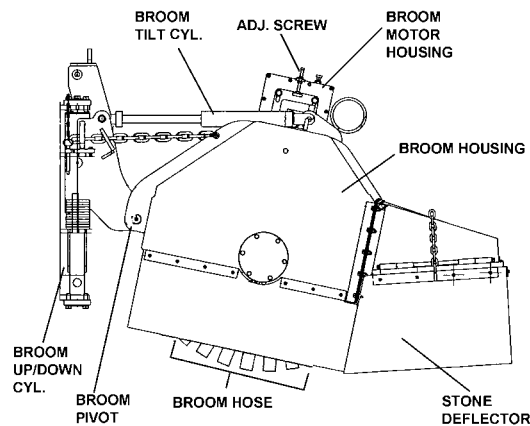
When not in use the ballast wing is raised and locked in place with a mechanical lockup.

### ROTATIONAL WINGS

Front and rear template doors can be extended (open) or retracted (closed).

The entire wing can be tilted to a 45° degree angle (either top in or top out)

Inner doors can be tilted to about a 90° angle (either top in or top out)

**BROOM**

The broom is designed to remove ballast from the top of the ties. It can be adjusted in height and tilt by separate controls in the operator cab. The broom is bi-directional - meaning it functions in forward travel or reverse, by use of a switch on the **overhead control panel** in the operator station. (Configuration of broom may change depending on the style you have chosen)

**STONE DEFLECTOR**

The stone deflector deflects broomed ballast and distributes it across the track to fill in voids in the cribs.

**FRONT BALLAST PLOW**

The purpose of the front ballast plow is to 1) transfer ballast from one side of the track to the other; 2) transfer ballast from the inside of the rails to the outside of the rails (or outside to inside); 3) eliminate windrows, or 4) for use as a snow plow. It consists of a left and right plow blade, the position of which is individually set by switch on the **center control console**.

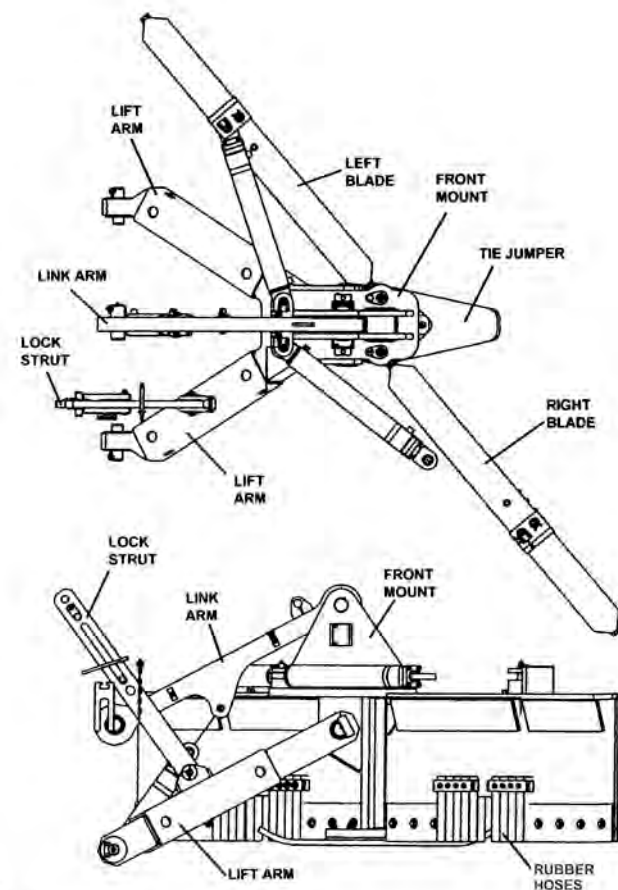
The height of the front plow is set by using a switch on the **center control console**.

The front plow is equipped with a "float" feature that is used in conjunction with the plow height switch. When you lower the front plow and use the "float" switch on the **center control console**, it will allow the plow to float between ties until the UP switch is used.

The rubber hoses on each of the blades are designed to sweep ballast away from the rail base and tie plates.

The tie jumper allows for smooth travel over ties during the ballast plowing operation.

The front plow carrier can be locked in at a specific height by use of shims on the lock strut.

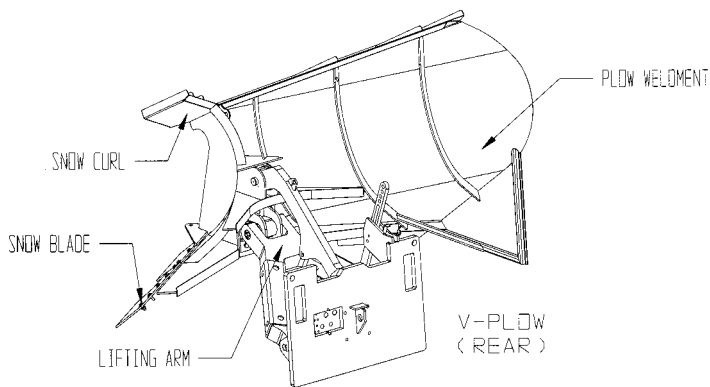


## SNOW FIGHTER (WINTER MACHINE)

### V-PLOW

The purpose of the V-Plow is clear snow away from the track. The V-Plow is a one-piece unit that does not allow for separate control of the left and right blades. The height of the plow is set by the use of toggle switch in the center console.

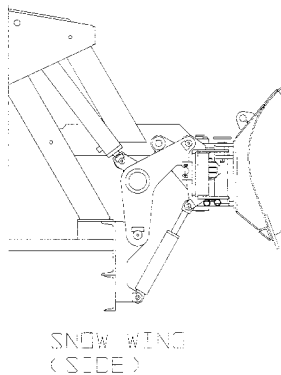
The v-plow carrier can be locked in at a specific height by use of shims on the lock strut.



### SNOW WING

The snow wing is designed to transfer snow away from the track. The blade on the snow wing can be tilted to about a 45° angle (either top in or top out).

When not in use the snow wing is raised and locked in place with a mechanical lockup.



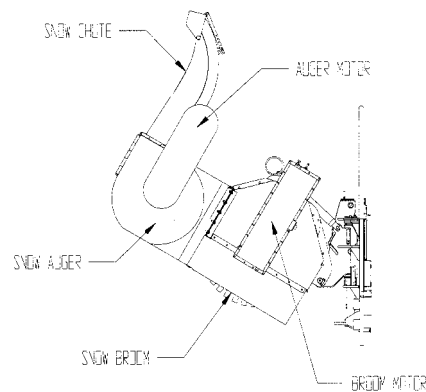
## SNOW BROOM/AUGER

The broom is designed to remove snow from the top of the ties and pushes it into the auger section of the snow screw. It can be adjusted in height and tilt by separate controls in the operator cab. The broom is bi-directional - meaning it functions in forward travel or reverse, by use of a button in the operator station. (Configuration of broom shown in drawing below may change depending on the style you have chosen)

Once the snow has been pushed from the broom to the auger, the snow exits the unit via the snow chute.

The position of the snow chute can be set by the use of a switch in the cab.

**NOTE:** The snow auger will only function correctly if the broom is rotating towards the snow auger.



## CONTROL PANELS AND CONSOLES

### NOTICE

#### GENERAL NOTE FOR THE CONTROL PANELS SHOWN IN THIS MANUAL:

Optional equipment is shown on the panels to allow this to be an “all-inclusive” manual. Location and orientation of switches may vary.

cab are described in more detail later in this section.

#### CENTER CONTROL CONSOLE

Contains engine and transmission controls (with the exception of alarm status indicators, which are located on the **Overhead Control Console**; front plow controls; and implement pump.

The controls and their functions as well as the controls and functions of other control panels in the cab are described in more detail later in this section.

#### OVERHEAD CONSOLE

Contains all wiper controls; lighting controls (work, travel, and optional perimeter and locomotive lighting); filter status indicators; controls and lockups for the broom, controls for the snowblower; optional lockups for the snow wings; and tilt controls for the ballast wing inner doors. This console also includes fuel, machine diagnostic and transmission gauges.

The controls and their functions as well as the controls and functions of other control panels in the

#### HAND CONTROLS

The hand controllers control the working functions of the ballast and snow wings. Actual function is determined by the type of wings installed on the machine.

Left hand controller controls the left wing, right hand controller controls the right wing

**FIGURE 1. OPERATOR STATION CONTROLS  
CENTER CONTROL CONSOLE**

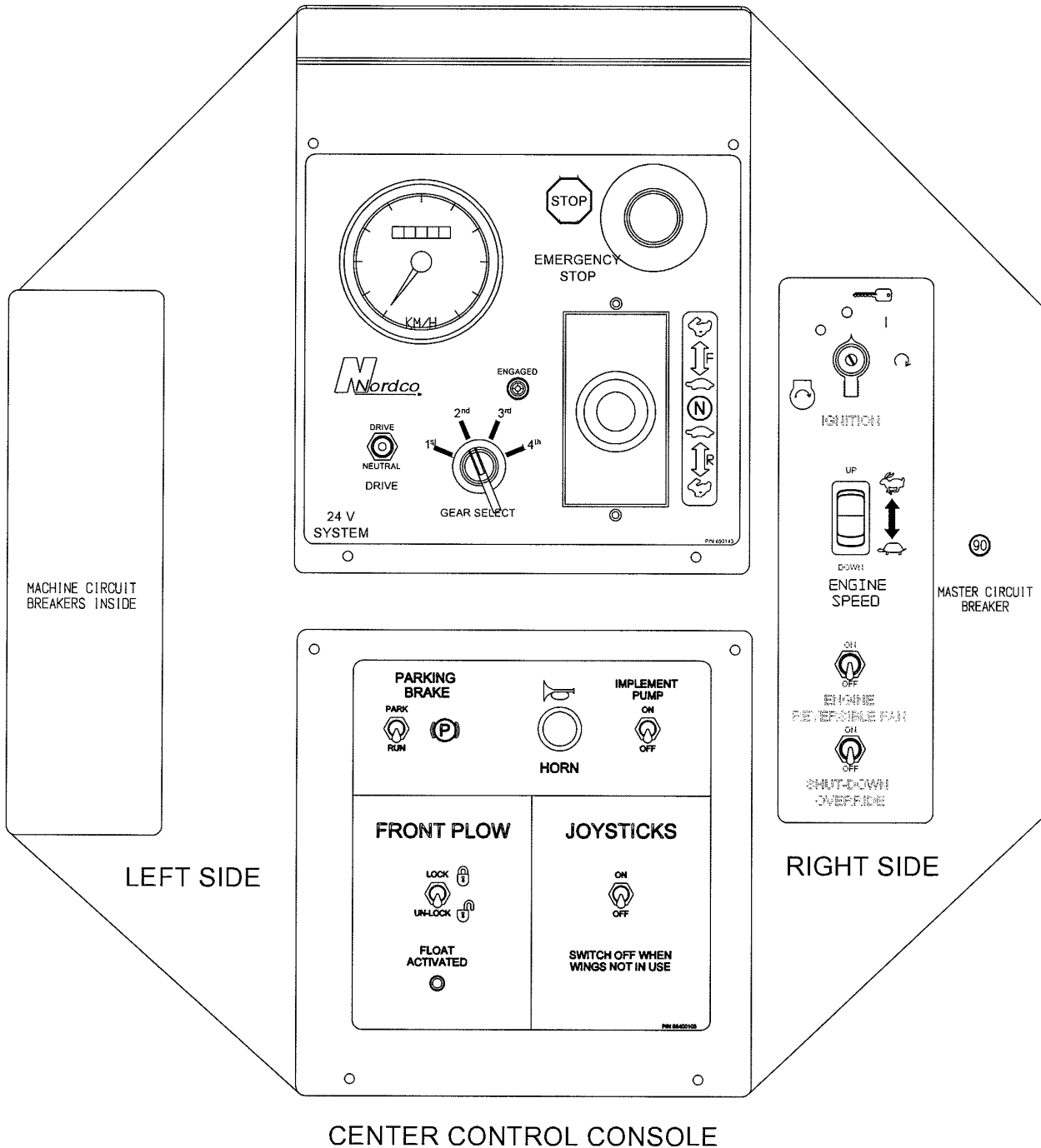

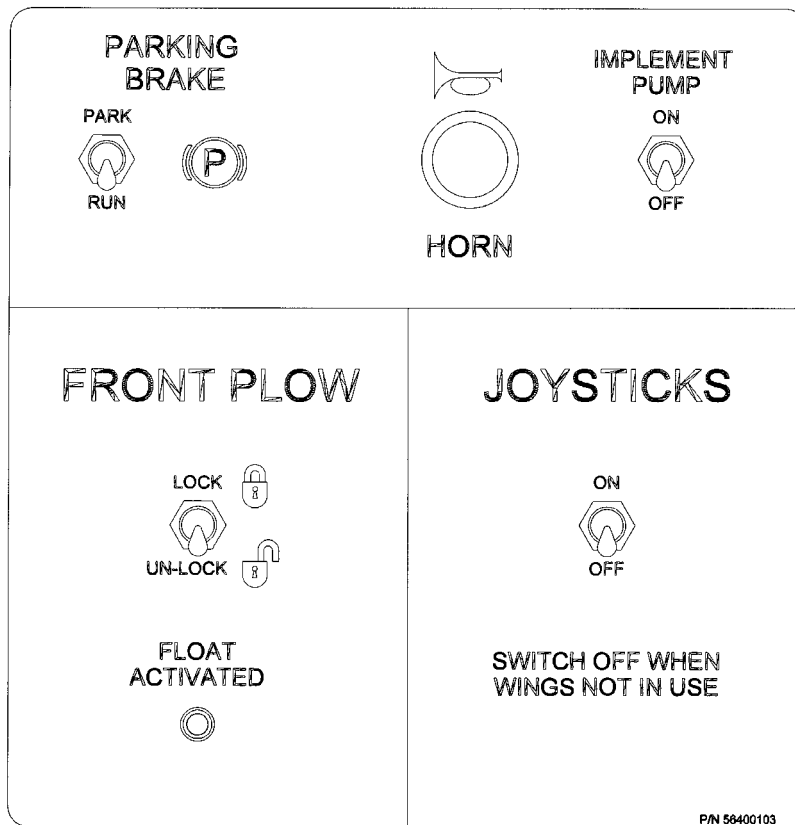


FIGURE 1. OPERATOR STATION CONTROLS  
**CENTER CONTROL CONSOLE**  
**(Top Front of Console)**

Instrument or Control	Type of Control	Functional Description
Transmission Control Switch	Three position momentary switch ON/OFF/ON	Used as "clutch" to switch gears up or down.
	Drive	Used with gear select switch to switch gears up or down. Switch must be used at each change of gear.
	Neutral	Shifts transmission into neutral. Place machine in neutral during engine startup and during hydraulic warmup.
Gear Select Switch And LED	Rotary Switch	Used with transmission control switch.
	1 <sup>st</sup> Gear (Low Gear)	Used during ballast regulating, brooming, switch cleaning in snow or when encountering extremely large or heavy ballast (or snow) conditions.
	2 <sup>nd</sup> Gear	Used during normal working conditions.
	3 <sup>rd</sup> Gear	Used for high speed snow plowing and track travel when speed is NOT a necessity.
	4 <sup>th</sup> Gear (High Gear)	Used for high speed track travel and highest speed snow plowing under light snow conditions.
	Engaged Light	Indicates transmission is in the "Drive" mode and engaged.
Speedometer	Gauge	Indicates travel speed of machine in either miles per hour or kilometers per hour.
Emergency Stop	Pushbutton	Stops the engine and shuts off electrical power.
	Push In	Deenergizes the fuel solenoid and main power relay.
	Pull Out	Resets (energizes) the solenoid and power relay.
Propulsion EDC	Electro/Hydraulic Valve	Used to control the speed of the machine.
	Forward Movement	Controls the forward propulsion of the machine. The further forward the joystick is moved, the faster the machine travels forward. Rabbit indicates "fast", Turtle indicates "slow"
		NEUTRAL POSITION
	Backward Movement	Controls the reverse propulsion of the machine. The further backward the joystick is moved, the faster the machine travels in reverse. Rabbit indicates "fast", Turtle indicates "slow"

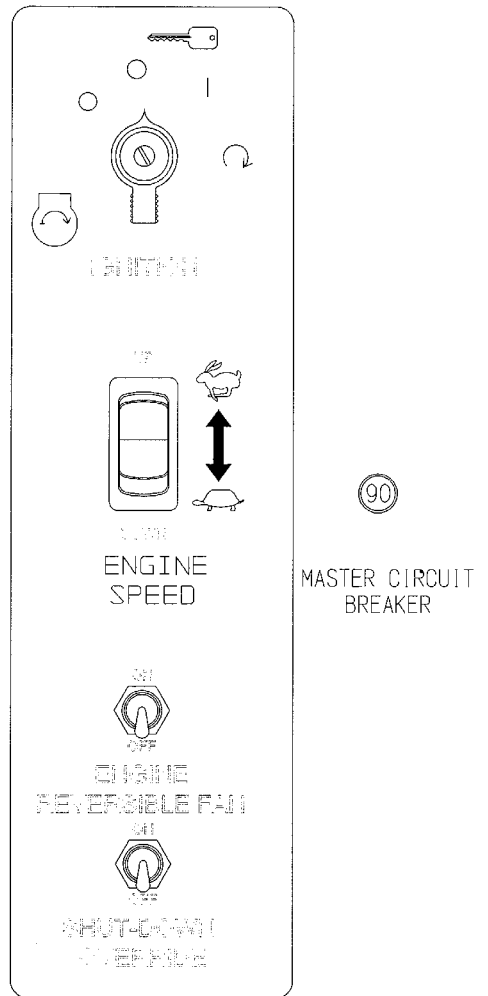
**FIGURE 2. OPERATOR STATION CONTROLS  
CENTER CONTROL CONSOLE  
(Bottom Front of Console)**



Instrument or Control	Type of Control	Functional Description
Plow Float ACTIVATED	LED	
Front Plow LOCK/UNLOCK Switch	Two position switch ON/OFF	Used to lock the front plow in the UP position for high speed travel or whenever the front plow is not being used. Must be unlocked when using the front plow.
JOYSTICKS	Two position ON/OFF	Disables joystick operation for travel or whenever wings are not being used during operation. MUST be in the OFF position during high speed track travel.
Park/Run Switch	Two position switch ON/OFF	Applies brakes.
Horn	Pushbutton	Press to sound horn.
Implement Pump Switch	Two position switch ON/OFF	Must be in the OFF position to start machine.
	ON	Enables use of front plow, broom, and wing functions.
	OFF	Disables use of front plow, broom, and wing functions.

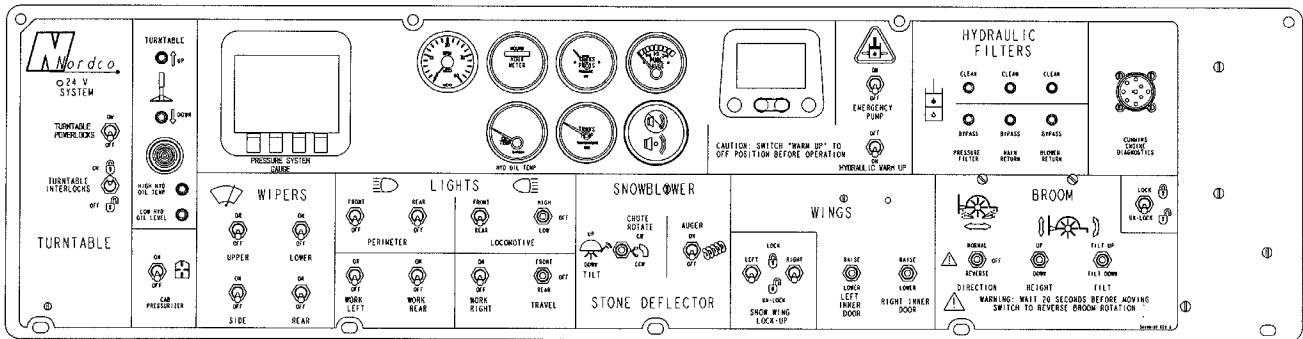


FIGURE 3. OPERATOR STATION CONTROLS  
**CENTER CONTROL CONSOLE**  
**(Right Side of Console)**



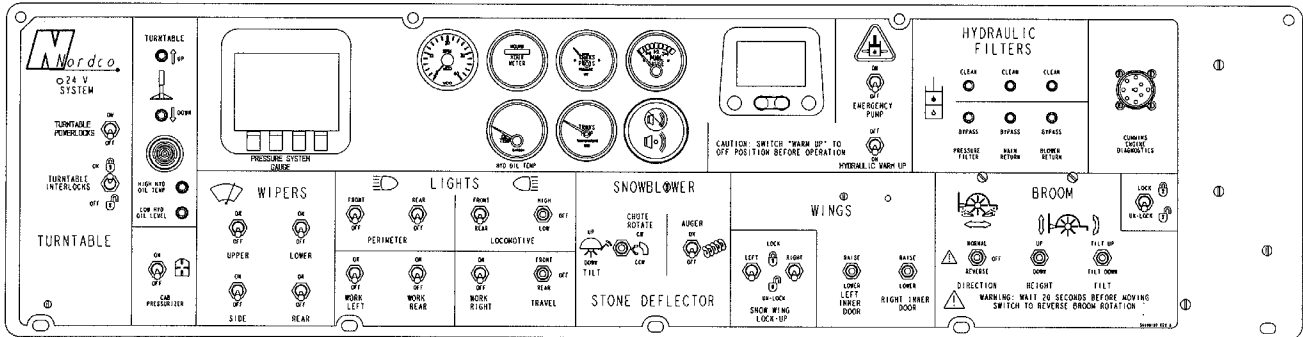
Instrument or Control	Type of Control	Functional Description
Ignition		The electrical system is energized by turning the switch (or optional key) to the right. Electrical power is cut off and the engine will stop when the key is turned to the full left (vertical) position.
Engine Speed Switch	Three position momentary switch	Used during work, travel and shutdown. Hold switch in position until desired RPM has been reached and then release switch.
Shutdown Override Switch	Two position ON/OFF	Overrides engine shutdown for EMERGENCY travel purposes. For use in situations when machine must be moved despite engine problems. When used, the engine is NOT protected from low oil pressure or high coolant temperature damage.
Engine Reversible Fan	Two position ON/OFF	Turns the AUTO reversing function of the FAN ON or OFF. Turn to the OFF position during winter when you are using a "Winter Front" on the engine.
Battery Disconnect Switch	Two position ON/OFF	Used to shut off all electrical power to the machine, with the exception of the emergency pumps.

**FIGURE 4. OPERATOR STATION CONTROLS  
OVERHEAD CONSOLE  
(Lower Portion of Console)**



Instrument or Control	Type of Control	Functional Description
Hyd Oil Level/Temp Indicating Lights (Option)	LED	Illuminates when there is an alarm condition such as low oil level or high oil temperature. When either light goes on, shut down machine and locate source of problem. Allowing machine to continue during this alarm state may cause catastrophic damage to the hydraulic system.
Cab Pressurizer Switch	Two position ON/OFF switch	Seals the cab using air pressure. This must be on during all ballast regulating operations (FRA requirement). Does not have to be on during snow operations.
Wiper Switches	Two position ON/OFF switches	Turns the corresponding wiper assembly on or off.
Light Switches	Two position ON/OFF switches	Turns the corresponding lights on or off.
Travel Switch	Three position ON/OFF/ON  FRONT  REAR	Two position switch. Used to select the direction of travel. Selects the front travel lights and rear marker lights, sounds backup alarm during reverse travel. Selects the rear travel lights and the front marker lights, sounds backup alarm during forward travel.
Locomotive Light Direction Selection	Two position ON/OFF switches	Front or Rear light will come on as selected. Used with the Beam Selection switch below.
Locomotive Beam Selection	Three position ON/OFF/ON switch	High: Sends 24V to the lights OFF: Turns off lights Low: Sends 12V to the lights

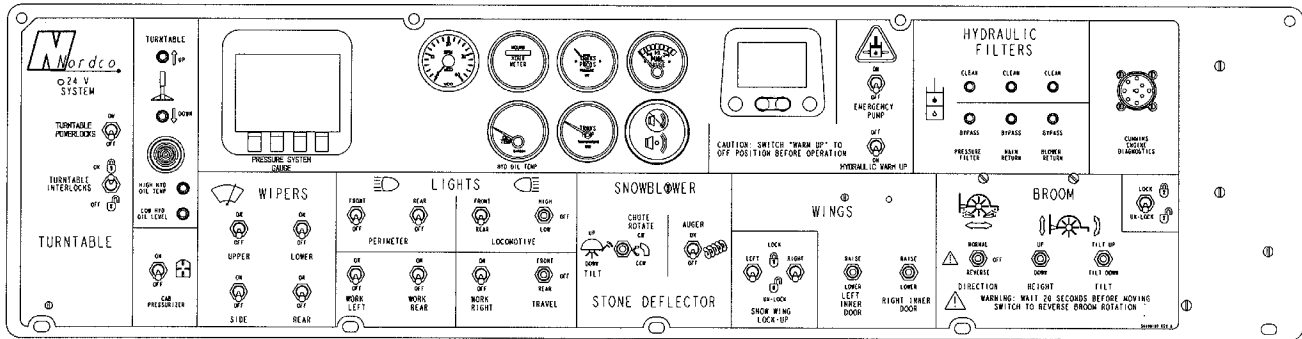
FIGURE 5. OPERATOR STATION CONTROLS  
**OVERHEAD CONSOLE**  
**SNOW BLOWER CONTROLS**  
 (Lower Portion of Console)



**NOTE: These controls are used along with the broom controls. Direction indicated (CW or CCW) is view from cab.**

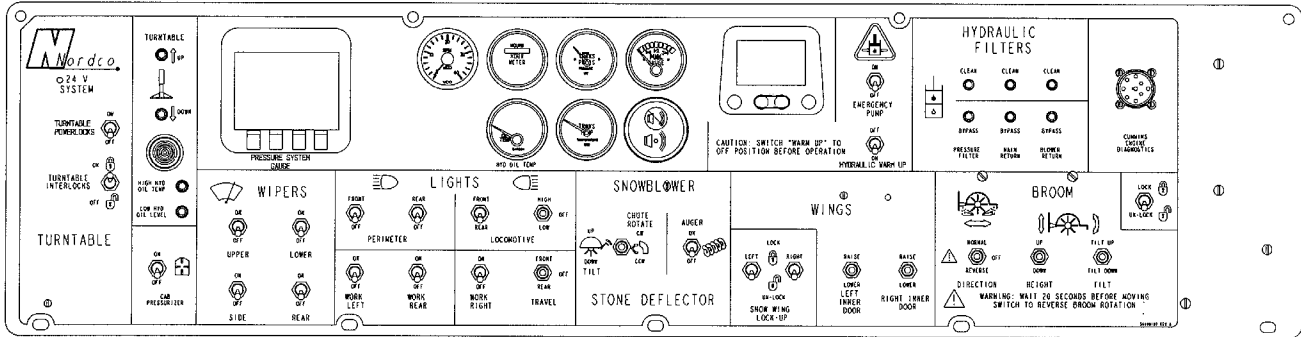
Instrument or Control	Type of Control	Functional Description
Chute Rotate Switch (Snow Machines Only)	Three position momentary switch ON/OFF/ON	Rotates the chute on the snowblower assembly.
	CW	Turns the chute CW
	RELEASE	Locks the chute in place
	CCW	Turns the chute CCW
Auger Switch (Snow Machines Only)	Two position switch ON/OFF	Turns on the auger.
	ON	Turns on the auger. Rotation is AWAY from machine.
	OFF	Turns off auger.

FIGURE 6. OPERATOR STATION CONTROLS  
**OVERHEAD CONSOLE**  
**WING CONTROLS**  
**(Lower Portion of Console)**



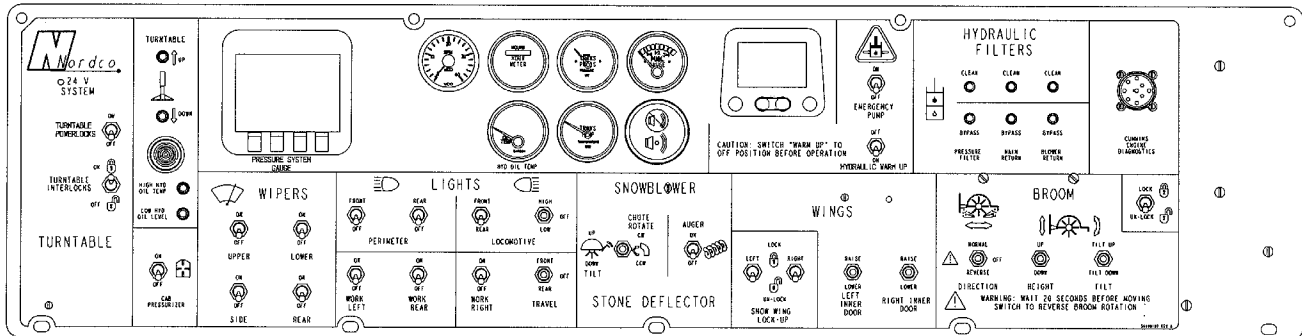
Instrument or Control	Type of Control	Functional Description
Snow Wing Lockup Switch Option	Two position ON/OFF switch.	Locks or unlocks the snow wing assembly. Snow wings must be raised and locked for all travel and whenever they are not being used.  NOTE: Ballast Wings are manually locked up.
Inner Door Switches  Option for Rotational Wings Only	Three position momentary switches ON/OFF/ON  UP  RELEASE  DOWN	Rotates the inner door on machines without fixed wings.  Raises inner door  Locks the door in place  Lowers inner door

FIGURE 7. OPERATOR STATION CONTROLS  
**OVERHEAD CONSOLE**  
**BROOM CONTROLS**  
 (Lower Portion of Console)



Instrument or Control	Type of Control	Functional Description
Lockup Switch	Two position ON/OFF switch.	Locks or unlocks the broom assembly. Broom must be raised and locked for all travel and whenever the broom is not being used.
Broom Sweep Switch	Three position switch ON/OFF/ON	Turns on the broom and also allows for change in direction of broom.
<b>ALLOW BROOM TO COME TO A STOP BEFORE CHANGING ROTATION DIRECTION!</b>	NORMAL	Powers up broom. Rotation is AWAY from machine.
	OFF	Turns off power to broom.
	REVERSE	Powers up broom, Rotation is TOWARD machine. Should not be used for any other purpose other than to clear jams.
Broom Height Switch	Three position momentary switch ON/OFF/ON	Raises and lowers the broom assembly.
NOTE: Make certain broom is UNLOCKED prior to operating this switch.	UP	Hold switch in the UP position until height is reached. Then release. Broom will remain in the UP position.
	RELEASE	
	DOWN	Hold switch in the DOWN position until desired height is reached. Then release. Broom will remain in the DOWN position.
Broom Tilt Switch	Three position momentary switch ON/OFF/ON	Tilts the assembly.
NOTE: Make certain broom is UNLOCKED prior to operating this switch.	UP	Tilts the assembly TOWARD the cab.
	RELEASE	Release the toggle switch to hold assembly in position.
	DOWN	Tilts the assembly AWAY from the cab.

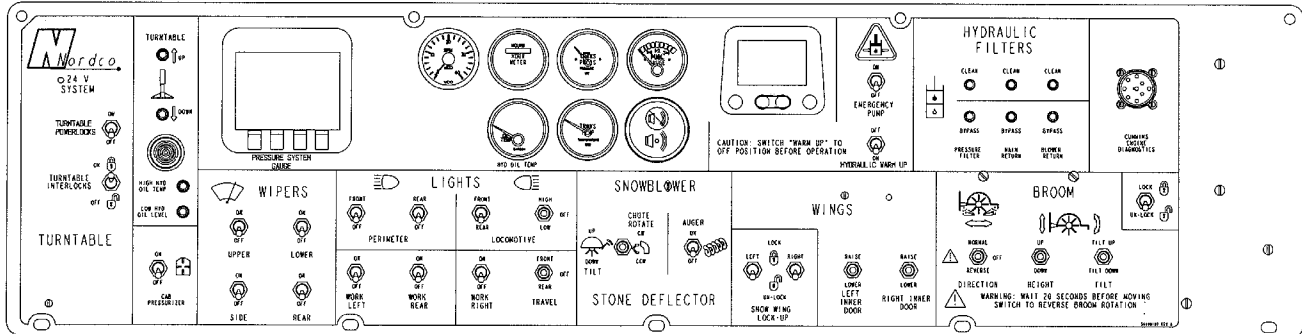
**FIGURE 8. OPERATOR STATION CONTROLS  
OVERHEAD CONSOLE – CONTINUED  
(Upper Portion of Console)**



Instrument or Control	Type of Control	Functional Description
Turntable Powerlocks	Two Position ON/OFF Switch	Engages or disengages the power locks on the turntable.
Turntable Interlocks	Two Position ON/OFF Switch	Used with the Turntable Powerlock in the Unlocked position. Prevents turntable from drifting down. Instructions for use of the turntable are given later in this manual.
Turntable Status Light and Alarm (Option)	LED	Gives status of turntable when illuminated. Alarm will sound when turntable is in the DOWN position and movement of machine is attempted.
	Green	Turntable is in the UP position.
	Red	Turntable is in the DOWN position.
Emergency Pump	Two Position Switch ON/OFF	Provides emergency hydraulic power in the event of a catastrophic failure. Allows workheads (plows, wings, broom, etc.) to be raised in an emergency.
Hydraulic Warmup Switch (Optional)	Two Position Switch ON/OFF	Used during Snow Operations to warm up hydraulic oil prior to operation. Switch MUST be in the off position before beginning work operations.
Filter Status Lights	LEDs	Lights will give status of filters
	Clean (Green)	Filter does not require servicing
	Bypass (Red)	Alarm State. Filter requires servicing or element requires replacing.
Cummins Engine Diagnostic Plug		Used only when a Cummins engine is installed on your machine.

SEE NEXT PAGE FOR GAUGES

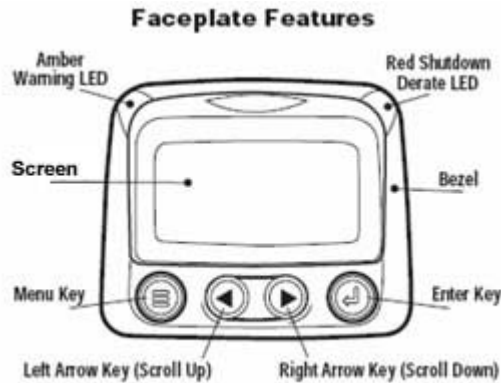
FIGURE 8. OPERATOR STATION CONTROLS  
**OVERHEAD CONSOLE – CONTINUED**  
 (Upper Portion of Console)



Instrument or Control	Type of Control	Functional Description
Pressure System Display Gauge (Option)	Gauge	Gives pressure readings of the Implement Pump, Charge Pump, Broom Pump and Track Pump. Refer to Figure 11 for basic details and the OTHER Tab for the OEM Instructions.
Tachometer	Gauge	Measures engine rpms.  John Deere Engines: Operate engine at or below 1200 rpm with no load for 1-2 minutes when warming up engine. Extend this to 2-4 minutes when operating at temperatures below freezing.
Hourmeter	Gauge	Keeps track of engine hours. Used mainly for planning scheduled maintenance.
Transmission Pressure	Gauge	Shows pressure of transmission fluid. Normal range is 230-290 psi.
Fuel Level	Gauge	Shows level of fuel on machine.
Hydraulic Oil Temp	Gauge	
Transmission Temp	Gauge	Shows temperature of transmission fluid. Normal temperature range is 180° F or less.
Audible Alarm	Gauge	Sounds whenever there is an alarm status on the Murphy Engine Diagnostic Gauge. Alarm will clear once the alarm state has been addressed.
Machine Diagnostic Gauge	LCD Gauge	Shows a complete range of engine parameters, including engine speed, oil pressure, coolant temperature, etc. See Figure 10 for more details.

**SEE NEXT PAGES FOR ENGINE DIAGNOSTIC GAUGE AND PRESSURE SYSTEM DISPLAY GAUGE**





**FIGURE 10. OPERATOR STATION CONTROLS  
ENGINE DIAGNOSTIC GAUGE  
(Upper Portion of Console)**



Turn the ignition switch to the first detent (power will come on, but engine is not started) and wait.

The Powerview will come on, and a “WAIT TO START-PREHEAT” message will appear on the screen. A light (Wait to Start) directly beneath the Powerview will turn on.

When the message disappears and the light goes out, it is safe to start the engine.

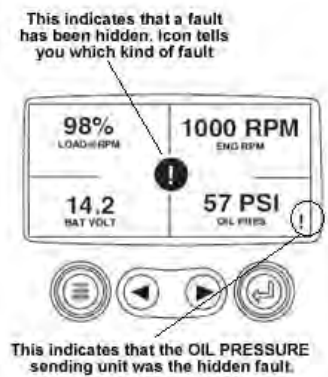
Instrument or Control	Type of Control	Functional Description
	Menu Key	The Menu Key is touched to either enter or exit the menu screens.  The <b>Menu</b> key is only used during factory setup procedures. (See Component Data Section for additional operation and setup instructions.)
	Left Arrow	Use the <b>left</b> to move to the left or upward in a <b>4-Up screen</b> . You can use the left arrow at any time to return to the previous screen.
	Right Arrow	Use the right arrow key to move to the right or downward in a 4-Up screen, or to move to the next set of 4 controls.
	Enter Key	The <b>enter key</b> is used when a fault occurs. Generally, any fault that occurs will come up on the screen at the time it happens. In order to go back to the original status screen you have to push the enter key once. <b>NOTE:</b> This will hide the fault screen until you 1) correct the fault, or 2) you press enter again.



Instrument or Control	Type of Control	Functional Description
Warning Light	Amber LED  <b>LED</b> status lights are located on the upper left and upper right sides of the powerview. When they are lit, the screen will tell you the fault, the code number for the fault, and the method to correct the fault.	The <b>Amber Warning LED</b> signals an ACTIVE FAULT code. When the light comes on, an abnormal condition exists. It is not necessary to shut down the engine immediately, but problem should be corrected as soon as possible. This light will remain on until all faults are corrected. Note: There may be more than one fault if <NEXT or MORE> appears at the bottom of the screen. You can also hide the faults by hitting the ENTER key. (Hitting the enter key again will take you back to the fault).  NOTE: Ignoring active fault codes (warnings or shutdown) could result in severe engine damage.
Shutdown Derate Light	Red LED  <b>LED</b> status lights are located on the upper left and upper right sides of the powerview. When they are lit, the screen will tell you the fault, the code number for the fault, and the method to correct the fault.	The <b>Red Shutdown Derate LED</b> signals a fault has occurred that requires immediate action. Shutdown the engine, but do not turn the switch to the off position. You must go through the codes on the screen and correct the problems prior to restarting the engine. (The Powerview remembers the errors).  NOTE: Ignoring active fault codes (warnings or shutdown) could result in severe engine damage.
Screen Display		Used to monitor engine and engine controls.

**HIDING FAULTS AND WARNINGS**

If you have hidden (hit the ENTER key at any fault condition), and have returned to the original 4-Up (or 1-Up) screen, the screen will now show icons in the upper right hand corner of a 1-UP screen or in the middle of the 4-UP screen (see figure below) to show you where the faults occurred. (In the 4-up shown below, the exclamation point appears in the middle and at the status that is showing a fault – the oil pressure.) Remember, the screen will show a <NEXT or MORE> if more than one error has occurred. Scroll through the screen until you find the individual component that has a fault. Highlight the component and press the ENTER key to read the fault.



Each fault icon has a different meaning and different methods to correct. These are:

- Indicates Auxiliary Gage Fault
- Indicates Fault Warning
- Indicates Derate or Shutdown Condition

NOTE: Faults can only be cleared when the fault has been corrected.

SHUTDOWN MACHINE as soon as possible when you have encountered a Shutdown Fault.

**FIGURE 11. OPERATOR STATION CONTROLS  
PRESSURE SYSTEM DISPLAY GAUGE**



**Navigation Using Soft Keys**



Brightness/ Contrast    Navigate Up    Navigate Down    Main Menu



Exit/ Back one screen    Navigate Up    Navigate Down    Select

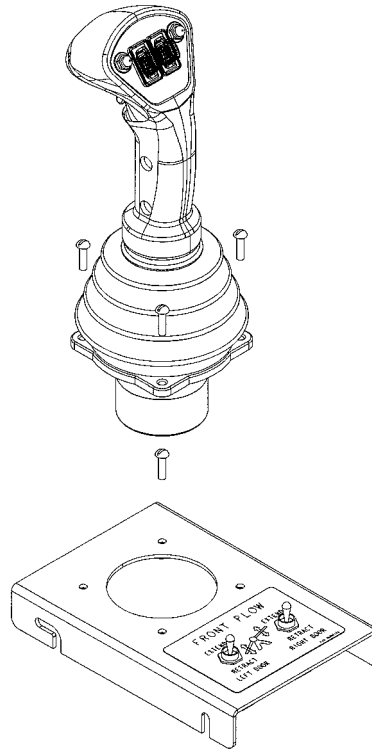


Exit/ Back one screen    Navigate Up    Navigate Down    Next

*Screen Navigation*

<b>Brightness/Contrast</b>	Press to access brightness and contrast settings.
<b>Navigate Up</b>	Press up to move up through menu items.
<b>Navigate Down</b>	Press up to move down through menu items.
<b>Main Menu</b>	Press to go to Main Menu screen.
<b>Exit/Back one screen</b>	Press to go back one screen.
<b>Select</b>	Press to make selection.
<b>Next</b>	Press to navigate to next digit or screen element.

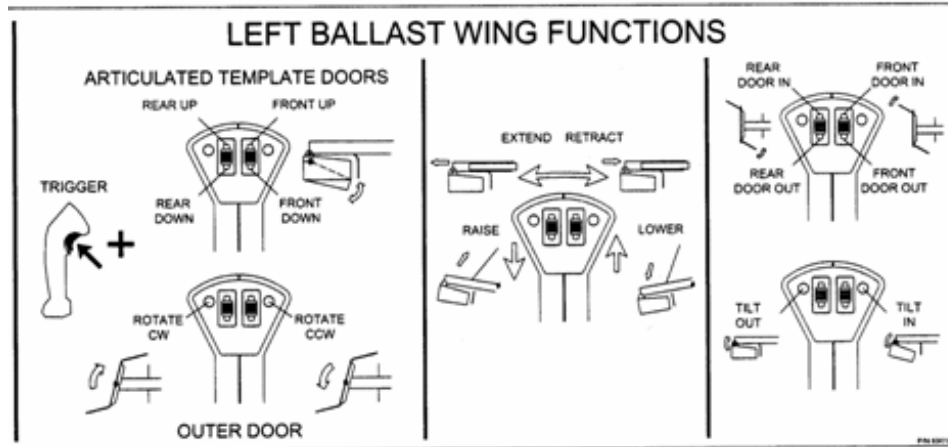
FIGURE 12. OPERATOR STATION CONTROLS  
LEFT HAND CONTROLLER BASE



Instrument or Control	Type of Control	Functional Description
Front Plow Doors	Three position momentary switch ON/OFF/ON for both right and left doors  LH Extend  LH Retract  RH Extend  RH Retract	Sets the position of the plow doors.  Moves LH plow door in a clockwise (CW) direction away from machine as long as switch is held. Release of switch locks in position.  Moves LH plow door in a counterclockwise (CCW) direction toward the machine as long as switch is held. Release of switch locks in position.  Moves RH plow door in a counterclockwise (CCW) direction away from the machine as long as switch is held. Release of switch locks in position.  Moves RH plow door in a clockwise (CW) direction toward the machine as long as switch is held. Release of switch locks in position.

**FIGURE 13. OPERATOR STATION CONTROLS  
JOYSTICK CONTROLS  
LEFT HAND CONTROLLER**

**Template Doors**



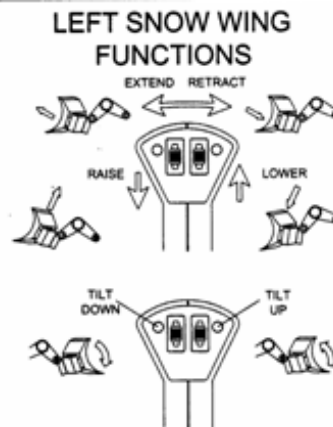
The left hand controller controls the functions of the LEFT Ballast or Snow Wing. The functions of the hand controller vary according to installed components. (Snow Wings, Articulated Ballast Wings, etc.) The trigger button on the hand controller is used with the ARTICULATED wings only.

<b>Instrument or Control</b>	<b>Type of Control</b>	<b>Functional Description</b>
With Trigger Articulated Wings (Option) Only	Left Button	Up/Down Raise/Lowers the articulated portion of the rear template doors
	Right Button	Up/Down Raise/Lowers the articulated portion of the front template doors
	Small Round Buttons	Outer Door Controls
	Left Button	Rotates (CW) the outer door
	Right Button	Rotates (CCW) the outer door
Without Trigger All Types of Wings	Hand Controller Movement:	Raise/Lowers and extend/retracts the LEFT snow wing.
	Left	Extends the wings out from the machine.
	Right	Retracts the wings toward the machine.
	Forward	Lowers the wing
	Backward	Raises the wing.

Instrument or Control	Type of Control	Functional Description
Without Trigger  All Types of Wings	Left Button	UP Moves Rear Template Door in, DOWN moves Rear Template Door out.
	Up/Down	
	Right Button	UP Moves Front Template Door in, DOWN moves Front Template Door out.
	Up/Down	
	Small Round Buttons	Outer Door Tilt Controls
	Left Button	Tilts the Door Out
Right Button	Tilts the Door In	

FIGURE 14. OPERATOR STATION CONTROLS

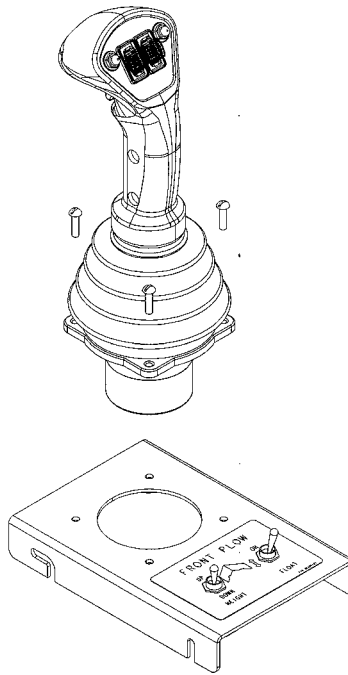
**JOYSTICK CONTROLS**  
**LEFT HAND CONTROLLER**  
**Snow Wings**



The left hand controller controls the functions of the LEFT Ballast or Snow Wing. The functions of the hand controller vary according to installed components. (Snow Wings, Articulated Ballast Wings, etc.)  
The trigger button on the hand controller is used with the ARTICULATED wings only.

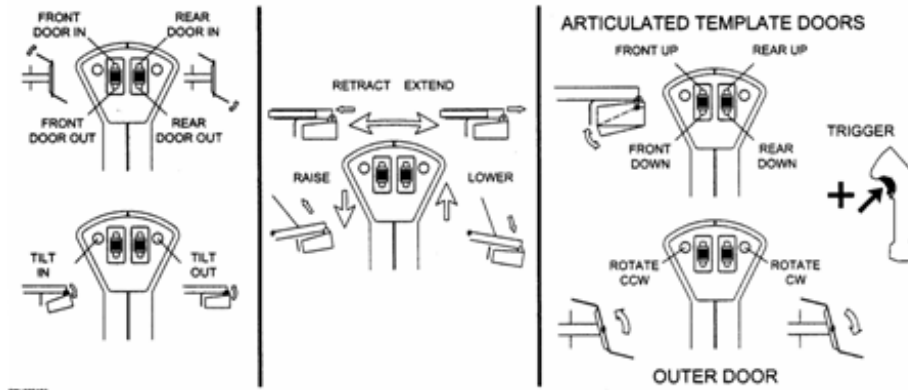
Instrument or Control	Type of Control	Functional Description
Snow Wing Functions (Optional)	Hand Controller Movement:	Raise/Lowers and extend/retracts the LEFT snow wing.
	Left	Extends the snow wings out from the machine.
	Right	Retracts the snow wings toward the machine.
	Forward	Raises the snow wing
	Backward	Lowers the snow wing
	Small Round Buttons	Tilts the snow wing blade up or down.
	Left Button	Tilts the snow wing blade down
	Right Button	Tilts the snow wing blade up

FIGURE 15. OPERATOR STATION CONTROLS  
**RIGHT HAND CONTROLLER BASE**



Instrument or Control	Type of Control	Functional Description
Plow UP/DOWN Switch	Three position momentary switch ON/OFF/ON	<p>Raises and lowers the front plow. Used with the Plow Float Switch</p> <p>UP Hold switch in the UP position until height is reached. Then release. Plow will remain in the UP position.</p> <p>CENTER DOWN Hold switch in the DOWN position until desired height is reached. Then release. Plow will remain in the DOWN position.</p> <p>NOTE: Make certain front plow is UNLOCKED prior to operating the plow UP/DOWN switch.</p>
Plow Float	Two position switch ON/OFF	<p>Use plow float to allow plow to follow contour of rail bed (ties) during plowing operations. Note: Plow float is automatically turned off and will remain off when Plow up is activated. When using plow power down, plow float will turn off but will resume when the plow power down button is released.</p> <p><b>WARNING!</b></p> <p>Activating Plow Float while the Plow is in the fully raised position will cause the plow to drop suddenly, which may cause personal injury and/or machine damage.</p>

FIGURE 16. OPERATOR STATION CONTROLS  
**JOYSTICK CONTROLS**  
**RIGHT HAND CONTROLLER**  
**Template Doors**  
**RIGHT BALLAST WING FUNCTIONS**



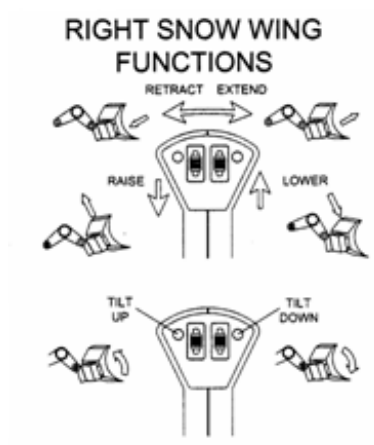
The left hand controller controls the functions of the RIGHT Ballast or Snow Wing. The functions of the hand controller vary according to installed components. (Snow Wings, Articulated Ballast Wings, etc.) The trigger button on the hand controller is used with the ARTICULATED wings only.

Instrument or Control	Type of Control	Functional Description
Without Trigger All Types of Wings	Left Button Up/Down Right Button Up/Down Small Round Buttons Left Button Right Button	UP Moves Rear Template Door in, DOWN moves Rear Template Door out. UP Moves Front Template Door in, DOWN moves Front Template Door out. Outer Door Tilt Controls Tilts the Door Out Tilts the Door In
Without Trigger All Types of Wings	Hand Controller Movement: Left Right Forward Backward	Raise/Lowers and extend/retracts the LEFT snow wing. Extends the wings out from the machine. Retracts the wings toward the machine. Lowers the wing Raises the wing.

<b>Instrument or Control</b>	<b>Type of Control</b>	<b>Functional Description</b>
With Trigger  Articulated Wings (Option) Only	Left Button	Up/Down
	Right Button	Up/Down
	Small Round Buttons	
	Left Button	
	Right Button	
		Raise/Lowers the articulated portion of the rear template doors
		Raise/Lowers the articulated portion of the front template doors
		Outer Door Controls
		Rotates (CW) the outer door
		Rotates (CCW) the outer door

FIGURE 17. OPERATOR STATION CONTROLS

**JOYSTICK CONTROLS  
RIGHT HAND CONTROLLER  
Snow Wings**



The left hand controller controls the functions of the RIGHT Ballast or Snow Wing. The functions of the hand controller vary according to installed components. (Snow Wings, Articulated Ballast Wings, etc.)

The trigger button on the hand controller is used with the ARTICULATED wings only.

<b>Instrument or Control</b>	<b>Type of Control</b>	<b>Functional Description</b>
Snow Wing Functions (Optional)	Hand Controller Movement:	Raise/Lowers and extend/retracts the LEFT snow wing.
	Left	Extends the snow wings out from the machine.
	Right	Retracts the snow wings toward the machine.
	Forward	Raises the snow wing
	Backward	Lowers the snow wing
	Small Round Buttons	Tilts the snow wing blade up or down.
	Left Button	Tilts the snow wing blade down
Right Button	Tilts the snow wing blade up	



***Preparing the Machine for Work***

As with any machine, pre-operational checks and preventative maintenance should be performed before using the machine. We suggest that you follow the guidelines listed below before actually operating the machine.

1. Position the machine on level track so fluid levels can be accurately checked and filled if necessary.
2. See TOWING at the end of this section if machine is to be towed to worksite.
3. Know and understand the use of all machine controls and instruments as described earlier in this section.
4. Perform the pre-operational inspection of the entire machine.
5. Perform applicable preventative-maintenance procedures in MAINTENANCE AND SERVICE section.
6. Be ready to operate the machine with an alert and safety-conscious attitude.
8. Understand the use of the machine's Lock-Ups. See LOCK-UPS section.
10. Wear proper safety clothing.

## PRE-OPERATIONAL CHECKLIST

NORDCO recommends that the following checks be performed WITHOUT electrical power, due to a possible battery drain.

<b>Main Control Panel Status:</b>	
	Gages checked for broken glass
	Emergency Stop pushbutton is pulled out.
	Parking Brake pushbutton is pushed in.
	Control Panel Switches set as follows: <input checked="" type="checkbox"/> Pump ON/OFF switch is OFF <input checked="" type="checkbox"/> Ignition switch is in OFF <input checked="" type="checkbox"/> Track Drive is set to NEUTRAL <input checked="" type="checkbox"/> Travel Lights are OFF <input checked="" type="checkbox"/> Lockup Switches Engaged <input checked="" type="checkbox"/> Work Lights are OFF <input checked="" type="checkbox"/> Emergency Stop pushbutton is pulled out. <input checked="" type="checkbox"/> Turntable Cylinder Lock Switch is in the ON position
<b>Machine Fluid Level Check</b>	
	Hydraulic Oil Tank is full
	Fuel Tank is full
	Engine Oil Reservoir is full
	Transmission Fluid Level is Full
<b>Machine Inspection</b>	
	Battery Disconnect Switch OFF
	Inspect for Leaks. Pay particular attention to hydraulic and fuel lines.
	Inspect all controls, wiring and switches for secure mounting

## LOCK-UPS



**FAILURE TO ENGAGE ALL LOCKUP DEVICES BEFORE PROPELLING AT TRAVEL SPEED CAN RESULT IN INJURY TO PERSONNEL AND/OR DAMAGE TO THE MACHINE.**

Use the following procedures to install or remove lock-ups. Note: With the exception of the suspension lockout, all lockups are to be in place during travel.

### Front Ballast Plow

Raise front plow to maximum height. Engage attachment lock using control in cab. Lower plow onto lock.

### Side Ballast Wing and Reversible Snow Wing

Raise wing to engage hook over mating portion in A-frame. Lower hook slowly by sliding wing in.

### Ballast/Snow Broom and Auger

Attach chains. Raise broom to maximum height. Engage attachment lock using control in cab. Lower broom onto locks.

### Turntable

Attach chains. Raise turntable to maximum height. Engage attachment lock using control in cab. Lower turntable onto hooks. **Note: Turntable locks MUST be removed prior to lowering or locks will be damaged.**

**Engine Operation**

Exhaust emissions caused by the use of the engine on this machine may cause cancer, birth defects, or other reproductive harm if inhaled.

**NOTICE**

Before starting a new or overhauled engine that has been in storage, consult the engine manufacturer's manual for initial start instructions. Failure to follow those instructions can result in serious engine damage.

**COLD WEATHER  
START UP INSTRUCTIONS**

For Temperatures Below 15° F (-10° C)

**NOTICE**

Failure to follow these instructions may prevent the machine from functioning correctly.

1. Disengage pump drive clutch, if so equipped.
2. Plug in engine block and pan heater if electricity is available. If not, the diesel fired heater **MUST** be run long enough to bring the engine temperature up to 80 to 100° F (27 to 38° C). (Approximately 30 minutes).
3. Start engine and let it run long enough to have a smooth idle (approximately 2 minutes).
4. Shut engine off and engage pump drive clutch, if so equipped.
5. Restart engine, set rpm to 1200.
6. Place the Warmup Switch on the Overhead Console to the WINTER position.
7. Turn on broom and implement pump.
8. Set engine rpm to 1500.
9. Let machine run until the temperature of the hydraulic oil in the tank reaches 80° F (27° C) and the control valves are warm to the touch. (Depending on the ambient temperature, this may take up to 1 hour.)

10. Once the hydraulic system has warmed up, make certain the transmission is in neutral. Move the forward and reverse controller completely forward for 30 seconds and then move to the complete reverse position for 30 seconds to warm up the hydrostatic pump and motor. Repeat 2-3 times before traveling machine.



Make certain the transmission controller is returned to neutral before releasing the parking brake.

**NORMAL STARTUP**

- A. Check engine oil level, engine coolant level, fuel oil level, and hydraulic oil level before attempting to start engine.
- B. Ensure that pump suction line gate valves are fully open.
- C. Ensure that parking brake is applied, track travel pump control is in NEUTRAL and track travel motor control is at LOW position.
- D. Set battery disconnect switch to ON position.
- E. Disengage clutch (if clutch is provided).
- F. Set throttle control slightly open.
- G. Depress shut-down override and hold
- H. Turn ignition key clockwise one indent (not all the way). Power will come on to the machine, but engine will not start. "Wait to Start Engine" light will come on under the Engine Diagnostic Gage.
- I. In cold weather, when engine is difficult to start, depress ether assist button while turning over engine. (Note: Ether assist button is optional).
- J. Release shutdown override when engine warning light goes out.
- K. Allow engine to idle until it warms up, then bring engine slowly to full rpm.
- L. Perform the startup check on the next page.

# OPERATION

## M7 Ballast Regulator & Snow Fighting Machine

---

### STARTUP CHECK

#### *Gauge Readings Checked:*

- Tachometer/Hourmeter: 2350 rpm (under load)
- Voltmeter: 13 to 15 Volts
- Engine Temperature: 160° to 185° F (71° to 85° C)
- Engine Oil Pressure: 40 to 60 psi (3 to 4 bar, 276 to 414 kPa)

#### *Light/Horn Status:*

- LIGHTS FUNCTION:
  - Travel Lights
  - Work Lights
  - Brake or Marker Lights
  - Locomotive Lights (opt)
  - Flood Lights (opt)

- HORNS/ALARMS FUNCTION:

- Travel Alarm
- Air Horn

#### *Operator Controls Function:*

- Hand Controllers
- Air Brakes

#### *Lock-Up Devices Engaged:*

- Front Ballast or Snow Plow
- Ballast or Snow Wings (Left and Right)
- Turntable
- Ballast/Snow Broom
- Stone Deflectors
- Suspension Lockout (if so equipped)
- Snow Screw and Blower (If so equipped)

## TRAVEL

It is important that you read about and understand all operating controls, Cautions, Warnings, and Dangers before traveling.



To avoid serious injury or death, make certain that the area around and under the machine is clear of all personnel and obstructions BEFORE travelling or working.



Failure to engage all lockup devices before propelling at travel speed can result in injury to personnel and/or extensive damage to the machine.

## ENGINE SPEEDS

Engine speed settings are infinitely variable using the engine speed control switch on the center control console.

## PROPELLING (TRACK TRAVEL OPERATION)

Before propelling this machine, make certain that all lockups are in their proper position. Check that suspension is not locked out (for machines with optional suspension lockouts).

1. Ensure that the engine and hydraulics are warmed up. Refer to "Engine Startup", earlier in this section.
2. Press the rocker switch (located on top of EDC control lever at the Operator Seat). Readout panel on Center Control Console will tell you what gear you are in. Continue to press until you have reached the selected gear. Refer to "Operator Controls" earlier in this section for recommended gears for specific operations.

3. Release the parking/emergency brake.
4. Adjust the engine speed using the throttle control on the center control console.
5. To Accelerate: Lift up the lock ring on the EDC control lever (located on the left hand controller box) and slowly move the lever in the desired direction until the desired speed is attained.
6. To Decelerate: Slowly move the lever towards the N or NEUTRAL position. Adjust engine speed accordingly.
7. To Change Direction: Bring the machine to a complete stop by moving the EDC controller to the NEUTRAL position. Accelerate as in Step 5.

## NOTICE

**NEVER ATTEMPT TO CHANGE DIRECTION OF MACHINE TRAVEL WITHOUT FIRST BRINGING THE MACHINE TO A COMPLETE STOP.**

## BRAKING (WORKING – SERVICE - BRAKES)

This machine is equipped with a fail-safe brake system. If there is a loss of air pressure, the brakes are spring applied.

**NOTE: The track drive system is strong enough to overpower the braking system. For this reason, ALWAYS NEUTRALIZE THE TRACK DRIVE SYSTEM SLOWLY BEFORE APPLYING THE BRAKES.**

One foot pedal operates the service brakes. Releasing of the brake pedal releases the brake.

### **PARKING/EMERGENCY BRAKES**

The parking brake is activated by a button located on the center control console. This button exhausts air from the spring brake chambers, permitting spring force to apply the service brakes. To operate the parking brake:

1. Push button to apply brakes.
2. Pull button to release brakes.

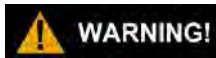
Always apply the parking/emergency brake before leaving the cab and when stopping for extended periods.

## Machine Setup

There are some adjustments which may have to be made due to varying conditions such as rail height and base width. Adjustments must be made to compensate for these conditions before operations can begin.



**SERIOUS INJURY OR DEATH CAN RESULT FROM REACHING INTO MOVING COMPONENTS WHILE THE MACHINE IS RUNNING. MAKE OBSERVATIONS FROM A SAFE DISTANCE.**



**ALWAYS TURN OFF MACHINE WHEN MAKING ADJUSTMENTS; UNLESS DIRECTED OTHERWISE. FAILURE TO COMPLY COULD RESULT IN PERSONAL INJURY AND/OR DAMAGE TO THE MACHINE.**

Read and understand all OPERATION procedures, warnings, and cautions before making adjustments.

### FRONT BALLAST PLOW HEIGHT ADJUSTMENT

Lower the plow assembly by pressing the Plow Power Down button on the Center Control Console (under the gauge portion of the panel) until the bottom of the tie jumper makes only slight contact with the highest ties. If tie jumper is set too low, it will wear out rapidly. **Adjust height with suspension locked out (if so equipped).**

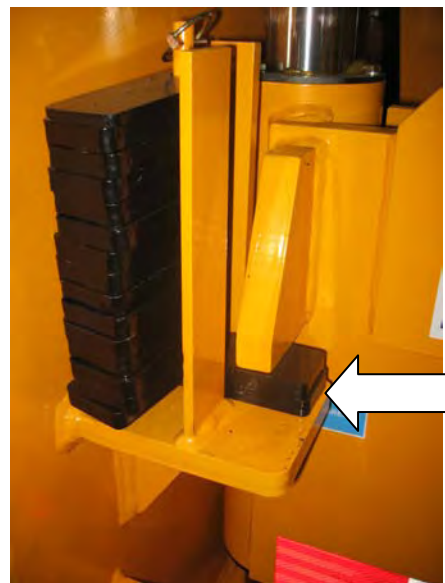
The valve section for the front plow has a "float" position. The "float" position is engaged automatically whenever the **DOWN** button is pressed and released. (The Float On light on the center control console will be lit when the plow is in the "float" position). Automatic float is turned off whenever the **UP** button on the handcontrollers is pressed. Use caution when pressing float when plow is raised.

### BROOM ANGLE AND HEIGHT ADJUSTMENTS

Set desired angle of stone deflector using broom rotate button on the **Broom Control Panel**. "Lock In" angle using chains on broom (if provided).

Height adjustments are made using the shims stored on the rear frame:

1. Remove all shims from holder.
2. Lower broom using **Broom Up/Down** button on the Broom Control panel until tips of broom hoses make contact with top of tie.
3. Determine shims needed by sliding the end of the shims between the stop bracket on the broom carrier and the shim mounting (at arrow in photo).
4. Raise the broom carrier until the bottom of the stop bracket clears the top of the shim holder tube.
5. Slide the required shims onto the holder tube, making certain they are parallel to the broom carrier.
6. Place the remaining shims back on the holder so that they are parallel to the back of the machine.



### **SNOW SCREW AND BLOWER**

Adjust blower paddles so that there is 1/8-inch clearance between rubber paddles and housing.

### **SEASONAL CHANGEOUT OF WINGS**

When switching from ballast wings to snow wings, keep all hoses and cables attached to the ballast wing components. Remove hoses from valves on "A" frame (directly behind engine) and the outer door tilt prox cable from the junction box on the "A" frame. Store as a complete unit for next seasonal changeout.



### MACHINE OPERATION



TO AVOID SERIOUS INJURY OR DEATH, MAKE CERTAIN THAT THE AREA AROUND AND UNDER THE MACHINE IS CLEAR OF ALL PERSONNEL AND OBSTRUCTIONS BEFORE TRAVELLING OR WORKING.



FAILURE TO ENGAGE ALL LOCKUP DEVICES BEFORE PROPELLING AT TRAVEL SPEED CAN RESULT IN INJURY TO PERSONNEL AND/OR DAMAGE TO THE MACHINE.

### GENERAL OPERATION

1. Make certain all STARTUP procedures have been followed before beginning working operations.
2. Make certain all lockups have been disengaged or removed and stored (as required).
3. If running during cold weather (32°F/ 0°C or lower) make certain the WARMUP switch on the Overhead console is in the WINTER position. It should be in SUMMER position for all other temperatures.

### FRONT BALLAST PLOW

Before lowering, ensure that the lockup pin is removed.



IF YOUR MACHINE IS EQUIPPED WITH BLADE FLANGE DEVICES, THEY EXTEND BELOW THE TOP OF THE RAIL. FAILURE TO RAISE THE PLOW (W/FLANGES) WELL CLEAR OF THE TOP OF THE RAIL MAY RESULT IN SEVERE MACHINE DAMAGE OR PERSONAL INJURY.

To operate the front ballast plow:

Plow is raised using either handcontroller and lowered using the button on the Center Control Console.

Using the buttons on the center control console, rotate the plow blades fully in or fully out as

required. **Note:** The plow should always be operated with the blade rotated either fully in or fully out, not part way through their rotation.

### BALLAST WINGS

The ballast wings are hydraulically operated with the valve handles in the control panel. To lower the wings, the wing in/out lever must first be pushed to clear the storage catch. Once clear, the wing may be lowered and positioned as desired. The wing raise/lower cylinder is equipped with a "cushion" feature. Upon raising the wing, the last portion of the stroke is affected. This is particularly noticeable when the hydraulic fluid is cold.

To operate:

1. Select the working side of the machine using the selector switch on the right hand controller box.
2. Using the hand controllers, push the Wing In/Out lever until it has cleared the storage catch.
3. Raise or lower the wings
4. Close, open, and/or tilt the ballast doors and template doors

### BROOM

The broom is hydraulically raised/lowered and rotated by use of switches on the **Broom Control Panel**. Similar to the front ballast/snow plow, there is a locking pin that must be removed prior to lowering the broom. The broom should be lowered and rotated to the desired position so that the broom flail hoses just contact the top of the ties.

To operate:

1. Raise or lower the broom
2. Reduce the engine speed to approximately 1500 rpm before starting the broom.
3. Start the broom by choosing the direction of rotation on the **Broom Control Panel**.
4. Once the broom has started, gradually increase the engine speed to the governed rpm.

### SNOW SCREW AND BLOWER

The snow screw and blower is raised/lowered using the Broom Up/Down control on the **Broom Control Panel**. The blower discharge chute is rotated using the Chute Rotate control on the Broom Control Panel.

Note: Mechanical stops are provided for the chute rotate, and care must be taken when rotating the chute so that the force generated does not damage the chain or associated panel.

To start the screw and blower:

1. Reduce the engine speed to approximately 1500 rpm.
2. Start the blower by choosing the direction of broom rotation on the **Broom Control Panel**.
3. Turn the auger control switch on the Broom control Panel to the ON position.
4. Once the screw and blower have started, gradually increase the engine speed to the governed rpm.

### Emergency Procedures

1. If a hydraulic hose fails, shut down the machine immediately, determine cause of failure, correct condition.
2. If indications on gauges are not within the normal range, shut down the engine. Repair before further operation.
3. Emergency cylinder actuation requires the use of the electric emergency pump. See below.

### Emergency Pump

**For operation of cylinders only:**

1. Make certain the ball valve at the dual pump (implement-gear) is in the CLOSED position. (Decal on valve will indicate open and closed positions.)
2. Depress emergency pump switch on the overhead console panel and then operate the controls for the piece of equipment that needs to be raised. Operate the pump in intervals, for a maximum of 15 seconds at a time. (The pump is designed for emergency use only and not to run continually.)
3. Return the ball valve at the pump to the OPEN position when you are through.

### EMERGENCY STOPPING

**The emergency shutdown should be used only when the engine does not respond to the normal stop engine procedure or in the event of an emergency where time is critical.**

To shut down the engine and stop all machine functions, push the EMERGENCY STOP pushbutton located on any of the control boxes.

Never use the emergency shutdown system except in an emergency. **DO NOT USE THIS METHOD AS A SHORTCUT TO TURNING OFF THE ENGINE!!**

### AFTER OPERATION

#### Parking or Locating Machine

1. Park or locate machine on level track area, if possible; and where it will not be exposed to excessive dust.
2. If the machine was towed, disconnect towing vehicle and set the brakes. Move the towing vehicle well clear of the parked machine.

Rotating Machine



Any machine can be hazardous when raised. Take all necessary precautions before raising the machine. Do not, under any circumstance, climb under machine when using the turntable.

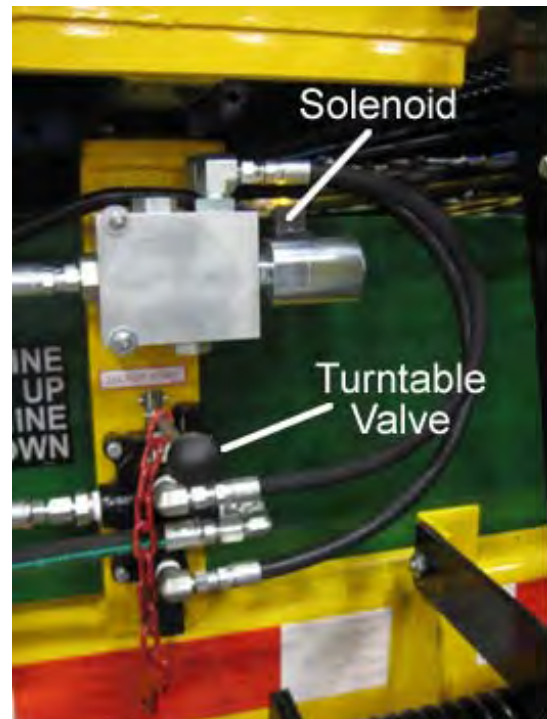
The machine has a turntable which allows the machine to be lifted off of the tracks and rotated. The only function of this turntable is to rotate the machine. The turntable base is stored under the machine and is attached to the turntable cylinder at all times. The turntable is operated by a valve handle on the right side of the control console.

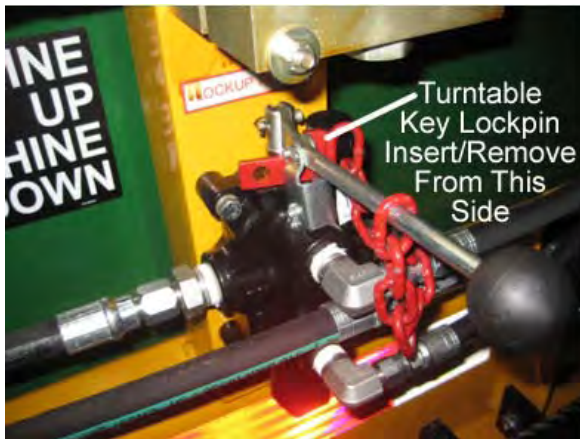
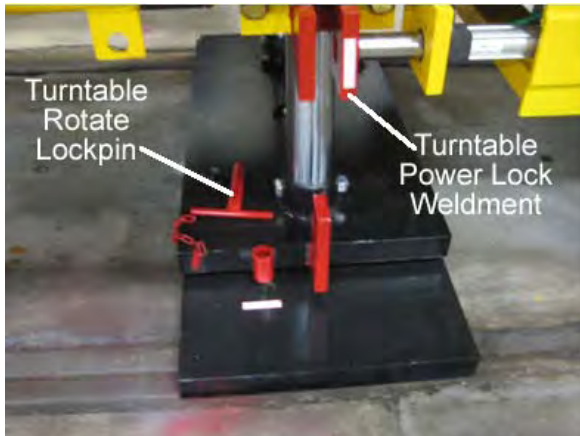
To lift and rotate the machine, proceed with the following steps (See Photos this page and next):

1. Raise all assemblies clear of the track structure and any obstacles.
2. Engage lockups on the front plow, broom, and wings/snow wings.
3. At the Upper Left Console, turn the Turntable Powerlocks Switch to the OFF position (Down).
4. At the Upper Left Console, turn the Turntable Interlock Switch to the ON position (Up).
5. At the left side of the Front Console, press the Yellow INTERLOCK button.
6. Exit the cab on the left side of the machine and go to the Turntable. Verify that the hydraulic power lock has disengaged. Lockup Pin should be fully retracted from the two red lockup weldments.
7. Look at the light on the solenoid above the turntable valve. If the light is on, the Turntable Interlock is active. Do not attempt to lift the machine if the light is not on!
8. At the turntable control valve next to the Left Stairs, remove the lock pin and move the handle up to raise the machine. When you have reached the height you want, release the handle and reinsert the pin.
9. Remove the Turntable Rotate lock pin on the Turntable base. Rotate the machine until the wheel flanges are properly aligned with the rail.
10. Reinsert the Rotate Lock pin into the TT base to prevent machine from swinging during lowering.
11. Remove lock key at the Turntable

12. Valve and press the valve handle down to lower the machine. Once lowered, make certain the turntable power lockup pin is aligned with the holes in the red lockup weldment.
13. Climb back into the cab.
14. At the Front Console, pull OUT the Yellow Interlock Button.
15. At the Upper Left Console, flip the Turntable interlock button to the OFF position (Down).
16. At the Upper Left Console, flip the Turntable Power Locks switch to the ON position. This will engage the power lockups on the turntable.
17. Verify that the locks have inserted correctly. If they haven't, repeat Steps 3-12. If they have, continue on with the next step.
18. Insert lock key back into place on the turntable valve.

NOTE: Two turntable mounting positions are provided so that the machine can be balanced depending on the attachments installed.





### Towing

Maximum towing speed is 20 m ph. Reduce speed accordingly as dictated by weather or track conditions. Remember that the machine weight may approach the weight of the towing vehicle. Maintain increased stopping distance accordingly.

It is strongly recommended that the prop shafts be removed before towing the machine.

### Towing Machines with 4-Speed Manual Transmissions

The following steps must be taken before towing your machine:

1. Install Lock-Ups. See LOCK-UPS section.
2. Make certain turntable has been raised.
3. Remove drive shaft if machine is to be towed a long distance.
4. Inspect the towing vehicle coupler for damage or loose parts.
5. Back towing vehicle to the machine and engage the couplers. Keep hands and fingers clear of the coupling device and all other pinch points.
6. Ensure that the coupling device is fully engaged, closed, and locked.
7. Install Brake Lock Pins. See Brake Assembly in Maintenance and Service for instructions on installing brake lock pins.
8. Ensure that the coupling device and rear frame members on the towing vehicles will not interfere with or restrict motion of any part of the machine when maneuvering.
9. When towing is complete, engage brake by removing the Brake Lock Pins.

This Page Intentionally Left Blank

**NORDCO'S SERVICE NETWORK**

If you have any questions regarding maintenance and service on this machine, please call your local Nordco Representative or:

Nordco Service Manager  
(414) 766-2342 (Wisconsin)  
1-800-445-9258 (USA and Canada)

The process will be faster if you have the following information in hand **before calling**:








1. The Machine and Model Name: **M7 Ballast Regulator/Snow Fighter**
2. The Serial Number

### LUBRICATION AND MAINTENANCE NOTES

The following are suggested notes and guidelines when performing maintenance on this machine.:

1. Always make certain that the engine has been turned off and the battery disconnect has been turned to the OFF position before performing maintenance on this machine.
2. NEVER clean, adjust, repair, or lubricate the machine while it is running unless specifically required and providing all necessary precautions have been taken.
3. When performing maintenance on the brakes, exercise caution if the spring brake is disassembled. Follow the brake manufacturer's instructions on the outside of the canister before attempting to disassemble the brake housing. The springs in the brake chamber are under tremendous compression.
4. Use caution when draining hot fluids from the machine. Splashing hot fluid can cause serious burns.
5. Never open the engine radiator cap while engine coolant is hot.
6. **NEVER** attempt to work under the machine while it is raised on the turntable unless special support blocks provided by Nordco are utilized.
7. Always ensure that all lubricating oils, fluids, and filters are clean and maintained as outlined in this section. It is important that lubrication is performed at the time intervals stated, or else machine damage could occur.
8. Always ensure that the engine radiator and oil cooler are kept clean and free of debris. Also ensure that the cooling fins are in good shape and not bent over.
9. Do not operate any hydraulic components until the hydraulic oil has reached a temperature of 60° F.
10. Always ensure that the pump suction lines and ball valves are open and not blocked, closed or collapsed.
11. Routine inspection of the clutch (if so equipped) should be performed. A properly engaged clutch requires 120 to 150 lbs. of force to engage.
12. Before starting the machine, inspect it for obvious defects and correct any problems discovered.
13. Inspect brake shoes for ice, and remove if present, before operation of the machine. If ice is allowed to build up on brake shoes, braking efficiency is greatly reduced.
14. Replace glass in cab if damaged. The structural integrity of the glass can be greatly diminished if nicks or damages occur to the outside.

**RECOMMENDED LUBRICANTS**

<b>KEY TO SYMBOLS USED</b> (In Maintenance Section Only)			
	Grease Daily		Fill Daily (Hydraulic Oil)
	Oil Daily (Engine Oil)		Fill Daily (Anti-Freeze)
			Grease Weekly (EP90)
			Grease Monthly
			Detailed Instructions Follow



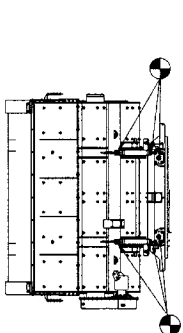
# MAINTENANCE

## M7 Ballast Regulator & Snow Fighting Machine

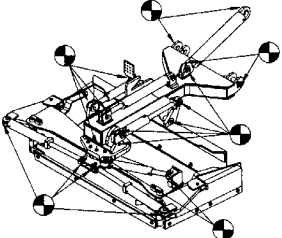
RECOMMENDED GREASES (NGLI #2)		
BRAND	DESCRIPTION/TYPE	
Lubriplate	3000	
Texaco	MolyTex EP2	
Mobil	MobilGrease Special	
Conoco	Super Sta M	
Amoco	Rykon Premium Moly 2	
Chevron	Moly Grease EP2	
RECOMMENDED HYDRAULIC OILS (ISO #46)		
BRAND	DESCRIPTION/TYPE	
Texaco	Rando Oil HD-46	
Mobil	DTE-25	
Shell	Tellus 46	
Conoco	Super Hydraulic Oil #46	
Amoco	Rykon Oil #46	
Citgo	Hydraulic A/W Oil #46	
RECOMMENDED ENGINE OILS		
BRAND	NORMAL TEMPERATURE SAE40	TEMPS UNDER 32°F SAE15W-40
Texaco	URSA Super Plus	URSA Super Plus
Mobil	Delvac 1240	Delvac Super 1200
Conoco	Fleet HD40	Fleet HD Multi-Grade
Amoco	300 Motor Oil	Premier II
Citgo	Citgard 500	Citgard 500

RECOMMENDED TRANSMISSION OILS		
BRAND	NORMAL TEMPERATURE	TEMPS UNDER 32°F
Valvoline		Dexron III/Mercon ATF
Shell	Donax TG	
RECOMMENDED GEAR OILS		
BRAND	DESCRIPTION/TYPE	
RECOMMENDED BROOM & SCREW DRIVE OILS		
BRAND	DESCRIPTION/TYPE	
Shell	Stringol B	

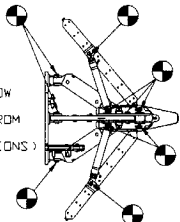
## DAILY MAINTENANCE



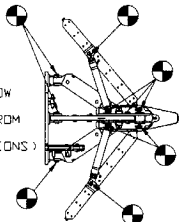
BROOM



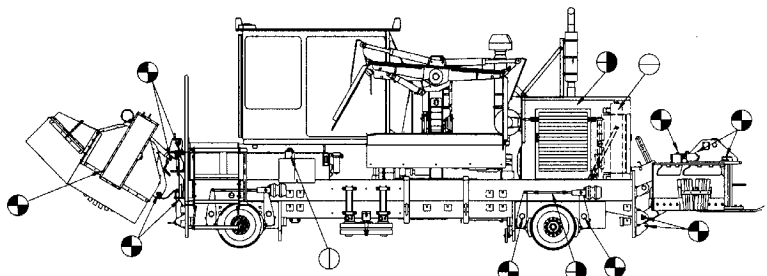
BALLAST WING  
(TYPICAL EACH WING)



FRONT PLOW  
LIFT CYL.  
HIDDEN FROM  
VIEW  
(2 POSITIONS)



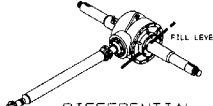
FRONT PLOW



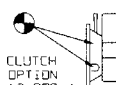
(TYPICAL EACH BRAKE ASSY)

SYMBOL	ITEM ELEMENT	LUBRICANT	FREQUENCY
⊗	GREASE NIPPLE SURFACE	GENERAL PURPOSE GREASE	DAILY
⊕	GREASE NIPPLE SURFACE	GENERAL PURPOSE GREASE	WEEKLY
⊖	ENGINE	ENGINE OIL	DAILY
⊙	HYDRAULIC TANK	HYDRAULIC OIL	DAILY
⊖	RADIATOR	ANTI-FREEZE	DAILY
⊕	AXLE HOUSING, 3 PUMP DRIVE	GEAR OIL	WEEKLY
⊗	BROOM DRIVE SCREW DRIVES	GENERAL PURPOSE MACHINE OIL	MONTHLY
⊕	POWERSHIFT TRANSMISSION	TRANSMISSION FLUID	DAILY

MISCELLANEOUS LOCATIONS



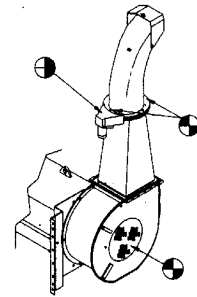
DIFFERENTIAL AND DRIVE SHAFT  
(TWO LOCATIONS)



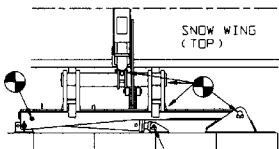
CLUTCH OPTION  
(2 POS.)

NOTE: MOST CYLINDERS REQUIRE GREASING AT EACH PIN END

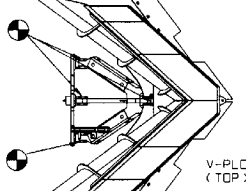
### BALLAST MACHINE



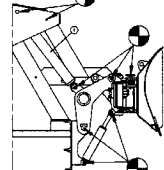
SNOW CHUTE



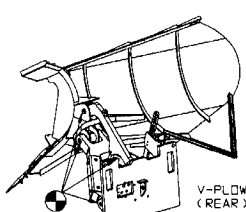
SNOW WING  
(TOP)



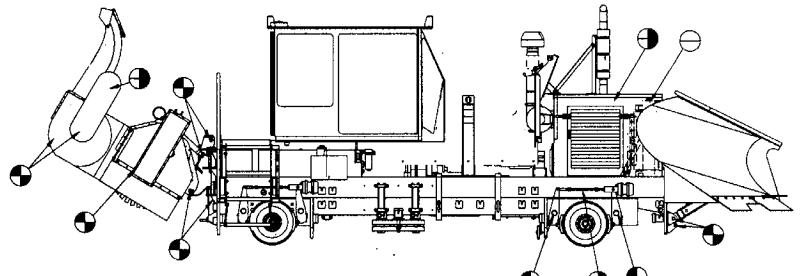
V-PLOW  
(TOP)



SNOW WING  
(SIDE)



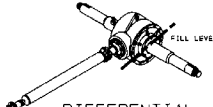
V-PLOW  
(REAR)



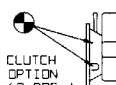
(TYPICAL EACH BRAKE ASSY)

SYMBOL	ITEM ELEMENT	LUBRICANT	FREQUENCY
⊗	GREASE NIPPLE SURFACE	GENERAL PURPOSE GREASE	DAILY
⊕	GREASE NIPPLE SURFACE	GENERAL PURPOSE GREASE	WEEKLY
⊖	ENGINE	ENGINE OIL	DAILY
⊙	HYDRAULIC TANK	HYDRAULIC OIL	DAILY
⊖	RADIATOR	ANTI-FREEZE	DAILY
⊕	AXLE HOUSING, 3 PUMP DRIVE	GEAR OIL	WEEKLY
⊗	BROOM DRIVE SCREW DRIVES	GENERAL PURPOSE MACHINE OIL	MONTHLY
⊕	POWERSHIFT TRANSMISSION	TRANSMISSION FLUID	DAILY

MISCELLANEOUS LOCATIONS







DIFFERENTIAL AND DRIVE SHAFT  
(TWO LOCATIONS)




CLUTCH OPTION  
(2 POS.)

NOTE: MOST CYLINDERS REQUIRE GREASING AT EACH PIN END

### SNOW MACHINE

DAILY (OR 8 HOURS, WHICHEVER COMES FIRST)			
Key:			
 = Refer to Mfr's Manual in Component Data  = More Detailed Instructions Follow			
LOC	ITEM	SYM	TASK
ENGINE	D1.		Check Engine Oil Level and Quality
	D2.		Check Engine Coolant Level and Quality
	D3.		Check Fuel Filter
	D4.		Inspect Cooling Fan on Engine (Cummins Engine Only)
	D5.		Inspect V-Belt for proper tension and condition
	D6.		Check Air Cleaner Indicators
	D7.		Drain Water Separator/Fuel Water Trap on Engine (if so equipped)
	D8.		Inspect Air Cleaner Dust Unloading Valve
	D9.		Inspect Engine Exhaust and Intake System for leaks and rain cap for fit.
	D10.		Check Case Drain Filter Indicator after resetting indicator
	D11.		- Reserved for Future Use -
HYD.	D12.		Check Hydraulic Oil Level and Quality (looking at gauge). Fill as necessary.
	D13.		Inspect Hoses and Fittings for Leaks
	D14.		Check Return Line Filter Condition Indicator
	D15.		- Reserved for Future Use -
	D16.		- Reserved for Future Use -
MISCELLANEOUS	D17.		Inspect Electrical Connections/Harnesses for Tightness
	D18.		Drain Air Tanks
	D19.		Fill Fuel Tank (end of day)
	D20.		Clean Windows on Cab (Optional Lexan Window Instructions)
	D21.		Inspect wheels, wheel nuts, brake shoes and check gap between brake shoes and wheels
	D22.		Check all brake chamber caging bolts
	D23.		Inspect rail sweeps and adjust as required
	D23.		Inspect rail sweeps and adjust as required
	D24.		Check machine for cracks or other structural damage
	D25.		Clean debris from machine before letting machine sit idle
	D26.		Grease brake lever pivot
	D27.		Grease Optional Clutch
	D28.		- Reserved for Future Use -
	D29.		- Reserved for Future Use -
D30.		- Reserved for Future Use -	
BALLAST WING	D31.		Grease Ballast Plow Up/Down Guide Rod
	D32.		Grease Ballast Wing Boom Pivot
	D33.		Grease Ballast Wing Rotary Plates
	D34.		Grease Ballast Wing Boom In/Out Tubes
	D35.		- Reserved for Future Use -
	D36.		- Reserved for Future Use -
BROOM	D37.		Grease Broom Housing Pivot
	D38.		Grease Broom Up/Down Guide Rod
	D39.		Grease Broom Shaft Bearing
	D40.		Lubricate Broom Drive Chain Chase
	D41.		- Reserved for Future Use -

### Detailed Daily Instructions

<b>D20. Clean Cab Windows ( Optional Lexan Windows)</b>	
<p><b>CLEANING PROCEDURES</b></p> <ol style="list-style-type: none"><li>1. Wash with a mild solution of soap* or detergent and lukewarm water.</li><li>2. Using a soft cloth or sponge, gently wash the sheet to loosen dirt and grime and rinse well with clean water.</li><li>3. To prevent water spotting, thoroughly dry with chamois or cellulose sponge.</li></ol> <p>*Compatible soaps and detergents:</p> <p>Windex, Joy, Fantastik, Top Job, Mr. Clean, Formula 409</p> <p>For more detailed instructions on how to remove grease, graffiti, etc., refer to the “Lexgard” Instructions in the component data section of this manual.</p>	<div style="border: 2px solid black; padding: 10px;"><p><b>CAUTION!</b></p><ol style="list-style-type: none"><li>1. <b>DO NOT</b> use abrasive or highly alkaline cleaners on LEXGARD laminates.</li><li>2. <b>Never</b> scrape LEXGARD laminates with squeegees, razor blades, or other sharp instruments. This may mar or gouge the MARGARD coating.</li><li>3. <b>Benzene, gasoline, acetone or carbon tetrachloride should never be used on LEXGARD laminates.</b></li><li>4. <b>DO NOT</b> clean LEXGARD in hot sun or at elevated temperatures.</li></ol></div>

WEEKLY MAINTENANCE

BROOM

BALLAST WING  
(TYPICAL EACH WING)

FRONT PLOW  
LIFT CYL.  
HIDDEN FROM  
VIEW  
(2 POSITIONS)

FRONT PLOW

(TYPICAL EACH BRAKE ASSY)

DIFFERENTIAL  
AND DRIVE SHAFT  
(TWO LOCATIONS)

CLUTCH  
OPTION  
(2 POS.)

SYMBOL	ITEM ELEMENT	LUBRICANT	FREQUENCY
⊙	GREASE NIPPLE GREASE SURFACE	GENERAL PURPOSE GREASE	DAILY
⊕	GREASE NIPPLE GREASE SURFACE	GENERAL PURPOSE GREASE	WEEKLY
⊖	ENGINE	ENGINE OIL	DAILY
⊗	HYDRAULIC TANK	HYDRAULIC OIL	DAILY
⊘	RADIATOR	ANTI-FREEZE	DAILY
⊙	AXLE HOUSING, 3 PUMP DRIVE	GEAR OIL	WEEKLY
⊖	BROOM DRIVE SCREW DRIVES	GENERAL PURPOSE MACHINE OIL	MONTHLY
⊕	POWERSHIFT TRANSMISSION	TRANSMISSION FLUID	DAILY

MISCELLANEOUS LOCATIONS

NOTE: MOST CYLINDERS REQUIRE GREASING AT EACH PIN END.

BALLAST MACHINE

SNOW WING  
(TOP)

SNOW CHUTE

SNOW WING  
(SIDE)

V-PLOW  
(TOP)

V-PLOW  
(REAR)

(TYPICAL EACH BRAKE ASSY)

DIFFERENTIAL  
AND DRIVE SHAFT  
(TWO LOCATIONS)

CLUTCH  
OPTION  
(2 POS.)

SYMBOL	ITEM ELEMENT	LUBRICANT	FREQUENCY
⊙	GREASE NIPPLE GREASE SURFACE	GENERAL PURPOSE GREASE	DAILY
⊕	GREASE NIPPLE GREASE SURFACE	GENERAL PURPOSE GREASE	WEEKLY
⊖	ENGINE	ENGINE OIL	DAILY
⊗	HYDRAULIC TANK	HYDRAULIC OIL	DAILY
⊘	RADIATOR	ANTI-FREEZE	DAILY
⊙	AXLE HOUSING, 3 PUMP DRIVE	GEAR OIL	WEEKLY
⊖	BROOM DRIVE SCREW DRIVES	GENERAL PURPOSE MACHINE OIL	MONTHLY
⊕	POWERSHIFT TRANSMISSION	TRANSMISSION FLUID	DAILY










MISCELLANEOUS LOCATIONS

NOTE: MOST CYLINDERS REQUIRE GREASING AT EACH PIN END.

SNOW MACHINE

# MAINTENANCE

## M7 Ballast Regulator & Snow Fighting Machine

WEEKLY (OR 40 HOURS, WHICHEVER COMES FIRST)			
<b>Key:</b>  = Refer to Lube Chart  = Refer to Mfr's Manual in Component Data  = More Detailed Instructions Follow			
LOC	ITEM	SYM	TASK
VARIOUS	W1.		Perform all Daily Lubrication and Maintenance Procedures
	W2.		Check Battery level and inspect/clean contact points and cables
	W3.		Check Transmission Fluid Level/Quality
	W4.		Check Fluid Level – 3 Pump Drive and clean breather
	W5.		Check Clutch Disconnect for Proper Engagement (Optional)
	W6.		Check Optional A/C Filter (During peak operation)
	W7.		Check Oil Level in Axle Housings and clean breathers
	W8.		Check Oil Level in Winches
	W9.		Check A/C filter during periods of heavy usage
	W10.		Clean Engine Air Filter Elements
	W11.		Blow Clean Radiator and Oil Cooler
	W12.		Inspect Engine Fan for Condition
	W13.		Inspect torque arms on front and rear axle assemblies
	W14.		Check Ballast Wing Plow Blades for Wear
	W15.		Check Front Plow Blades and Tie Jumper for Wear
	W16.		Check Wheel Gage using the Wheel Gage Template in the tool box.

Detailed Weekly Instructions

<b>W6. Check Clutch Disconnect for Proper Engagement (Optional)</b>	
<p>When the clutch handle is disengaged, it should take 150 ft/lbs to engage and to snap in place. This should be done with a torque wrench which can be attached to the clutch handle at the base.</p> <p>If adjustment is needed, remove the inspection cover on the clutch housing.</p> <p>W6-Cluch inspection and adjustment</p> <ul style="list-style-type: none"> <li>- when the clutch handle is disengaged , it should take 150 ft LBS to engage and to snap in place</li> <li>- this should be done with a torque wrench which can be attached to the clutch handle at the base.</li> <li>- -If adjustment is needed , remove the inspection cover on the clutch housing</li> <li>- by looking at the clutch assembly , there is a spring loaded pin that can be depresst and the large</li> <li>- Adjusting nut can be freely advanced to the next increment , at this time check the torque it takes to snap the clutch in place.</li> <li>- If not enough go to next increment.</li> </ul>	

<b>W12. Blow Clean Radiator and Oil Cooler</b>	

<b>W14. Inspect torque arms on front and rear axle assemblies</b>	



## MONTHLY MAINTENANCE

**BROOM**

**BALLAST WING**  
(TYPICAL EACH WING)

**FRONT PLOW**  
LIFT CYL.  
HIDDEN FROM VIEW  
(2 POSITIONS)

**FRONT PLOW**

**(TYPICAL EACH BRAKE ASSY)**

SYMBOL	ITEM ELEMENT	LUBRICANT	FREQUENCY
☉	GREASE NIPPLE GREASE SURFACE	GENERAL PURPOSE GREASE	DAILY
☉	GREASE NIPPLE GREASE SURFACE	GENERAL PURPOSE GREASE	WEEKLY
☉	ENGINE	ENGINE OIL	DAILY
☉	HYDRAULIC TANK	HYDRAULIC OIL	DAILY
☉	RADIATOR	ANTI-FREEZE	DAILY
☉	AXLE HOUSING, 3 PUMP DRIVE	GEAR OIL	WEEKLY
☉	BROOM DRIVE SCREW DRIVES	GENERAL PURPOSE MACHINE OIL	MONTHLY
☉	HYDRAULIC TRANSMISSION	TRANSMISSION FLUID	DAILY

**MISCELLANEOUS LOCATIONS**

**DIFFERENTIAL AND DRIVE SHAFT**  
(TWO LOCATIONS)

**CLUTCH OPTION**  
(2 POS.)

**NOTE: MOST CYLINDERS REQUIRE GREASING AT EACH PIN END.**

### BALLAST MACHINE

**SNOW WING**  
(TOP)

**SNOW CHUTE**

**SNOW WING**  
(SIDE)

**V-PLOW**  
(TOP)

**V-PLOW**  
(REAR)

**(TYPICAL EACH BRAKE ASSY)**

SYMBOL	ITEM ELEMENT	LUBRICANT	FREQUENCY
☉	GREASE NIPPLE GREASE SURFACE	GENERAL PURPOSE GREASE	DAILY
☉	GREASE NIPPLE GREASE SURFACE	GENERAL PURPOSE GREASE	WEEKLY
☉	ENGINE	ENGINE OIL	DAILY
☉	HYDRAULIC TANK	HYDRAULIC OIL	DAILY
☉	RADIATOR	ANTI-FREEZE	DAILY
☉	AXLE HOUSING, 3 PUMP DRIVE	GEAR OIL	WEEKLY
☉	BROOM DRIVE SCREW DRIVES	GENERAL PURPOSE MACHINE OIL	MONTHLY
☉	HYDRAULIC TRANSMISSION	TRANSMISSION FLUID	DAILY




**MISCELLANEOUS LOCATIONS**







**DIFFERENTIAL AND DRIVE SHAFT**  
(TWO LOCATIONS)

**CLUTCH OPTION**  
(2 POS.)

**NOTE: MOST CYLINDERS REQUIRE GREASING AT EACH PIN END.**

### SNOW MACHINE




MONTHLY (OR 150 HOURS, WHICHEVER COMES FIRST)			
<b>Key:</b>  = Refer to Lube Chart  = Refer to Mfr's Manual in Component Data  = More Detailed Instructions Follow			
LOC	ITEM	SYM	TASK
VARIOUS	<b>M1.</b>		Perform all Daily and Weekly Lubrication and Maintenance Procedures
	<b>M2.</b>		Change engine oil and oil filter
	<b>M3.</b>		Change engine fuel filter and fuel/water separator element
	<b>M4.</b>		Change engine coolant filter
	<b>M5.</b>		Inspect oil level in broom drive and check chain tension
	<b>M6.</b>		- Reserved for Future Use -
	<b>M7.</b>		Inspect cylinder lugs and spherical bearings and replace as required
	<b>M8.</b>		Inspect engine crankcase breather for air flow
	<b>M9.</b>		Inspect engine cooling system (leaks, connections, and hoses)
	<b>M10.</b>		Check air compressor coolant lines
	<b>M11.</b>		Ensure engine mounts, fuel tank mounts and hydraulic tank mounts are secure
	<b>M12.</b>		Lubricate throttle cable with graphite
	<b>M13.</b>		Test insulation of axles (if insulated)
	<b>M14.</b>		Lubricate Broom Drive Chain
	<b>M15.</b>		Lubricate Snow Blower (Optional) Drive Chain
	<b>M16.</b>		- Reserved for Future Use -


QUARTERLY (OR 500 HOURS, WHICHEVER COMES FIRST)			
<b>Key:</b>  = Refer to Lube Chart  = Refer to Mfr's Manual in Component Data  = More Detailed Instructions Follow			
LOC	ITEM	SYM	TASK
	Q1.		Perform all Daily, Weekly and Monthly Lubrication and Maintenance Procedures
	Q2.		Change fluid in transmission
	Q3.		Change fluid in axle housing
	Q4.		Change fluid in 3-pump drive
	Q5.		- Reserved for Future Use -
	Q6.		- Reserved for Future Use -
	Q7.		- Reserved for Future Use -
	Q8.		Replace hydraulic and fuel tank breathers and filler screens
	Q9.		Inspection radiator and oil cooler and steam clean if necessary
	Q10.		Measure wheel diameters for uniform wear within set
	Q11.		Inspect engine cooling system for contamination and test anti-freeze rating
	Q12.		Inspect axle bearing housing wear pads for wear

### Detailed Quarterly Instructions

<b>Q2. Change fluid in transmission</b>	
<b>Q3. Change fluid in axle housing</b>	
<b>Q4. Change fluid in 3-pump drive</b>	

**YEARLY (OR 2000 HOURS, WHICHEVER COMES FIRST)**

**Key:**  = Refer to Lube Chart  
 = Refer to Mfr's Manual in Component Data  = More Detailed Instructions Follow

LOC	ITEM	SYM	TASK
	Y1.		Perform all Daily, Weekly, Monthly, and Quarterly Lubrication and Maintenance Procedures
	Y2.		Drain and clean hydraulic tank. Replace fluid and wash/replace strainers
	Y3.		Drain and clean fuel tank
	Y4.		Test A/C performance and charge with refrigerant, if required
	Y5.		Replace air dryer desiccant cartridge, if equipped
	Y6.		Inspect Suction Strainer Element

<b>Y5. Replace air dryer desiccant cartridge</b>