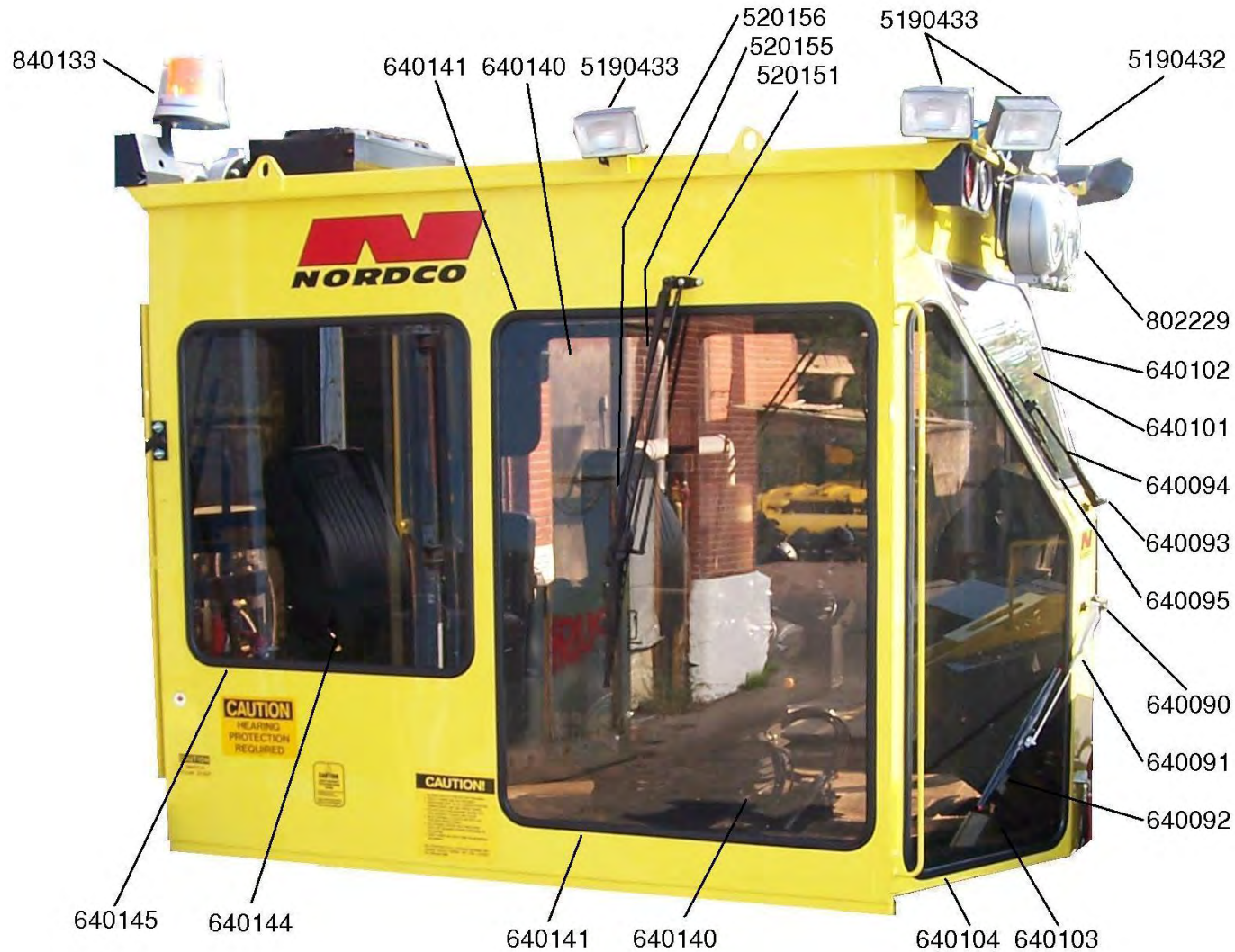


**FIGURE 1-1. OPERATOR STATION
Tall Cab and Windows
S/N 800300 Only**



NOTE: Locomotive lights and side window wiper assembly are options.

**FIGURE 1-2. OPERATOR STATION
Seat and Controls**



**FIGURE 1-3. OPERATOR STATION
A/C & Heat
S/N 800300 and Above**



**FIGURE 1-4. OPERATOR STATION
Cab Pressurizer
S/N 800300 and Above**

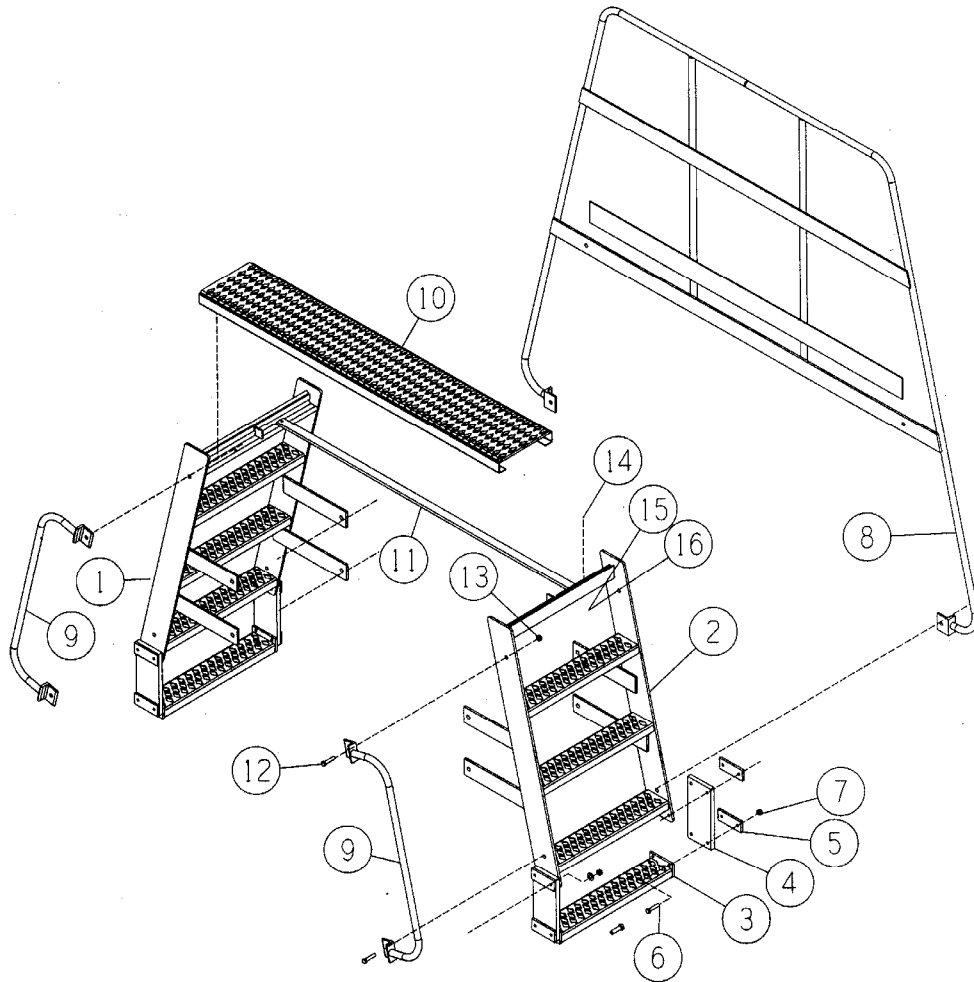


**FIGURE 1-5. OPERATOR STATION
Perimeter Lighting (Option)**



NOTE: This assembly is used on snow machines equipped with a V-Plow.

FIGURE 1-6. OPERATOR STATION Cab Steps



ITEM NO.	PART NO.	DESCRIPTION	UNITS PER MACHINE
1	700367	Step Assembly (5" Deep Steps).....	2
2	700358	Step Frame w/3 Steps.....	1
3	700362	Bottom Step	1
4	680098	Rubber Step Hanger	2
5	700363	Hanger Retainer.....	4
6	0339	HH Bolt 3/8-16 x 2.....	8
7	2660	Stover Nut, 3/8	8
8	700364	Rear Handrail	1
9	700365	Step Handrail	2
10	700361	Walkway (Grip Strut)	2
11	700391	Step Connector Bar.....	1
12	0559	HH Bolt 1/2-13 x 1-1/2.....	8
13	3042025	Stover Nut, 1/2-13	8
14	0331	HH Bolt, 3/8-16 x 1-1/2.....	2
15	2506	Stover Nut, 3/8-16	2
16	2762	3/8" Lockwasher	2

FIGURE 2-1-1. Axles and Drive Housing 35 mph w/24" Demountable Wheels

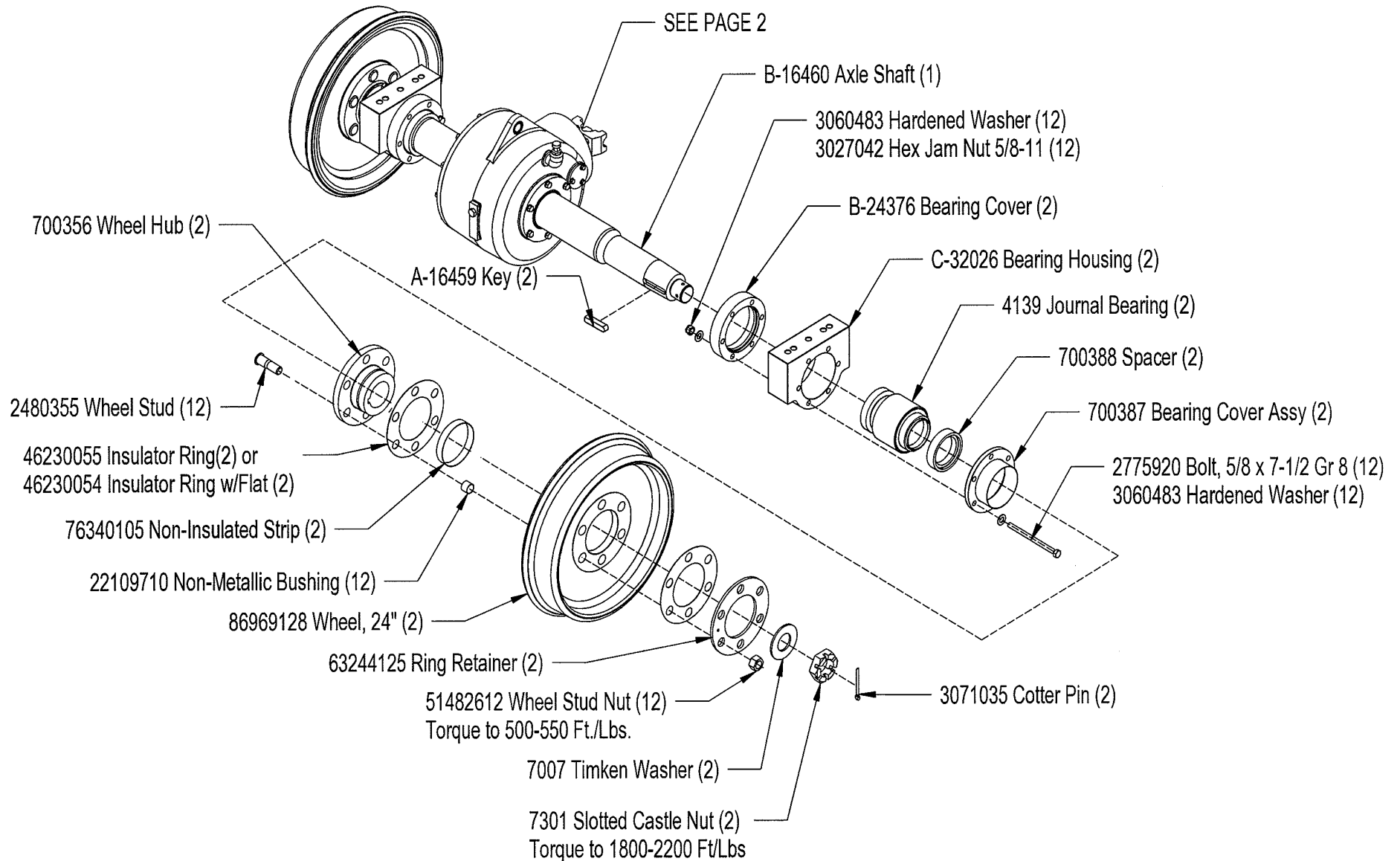
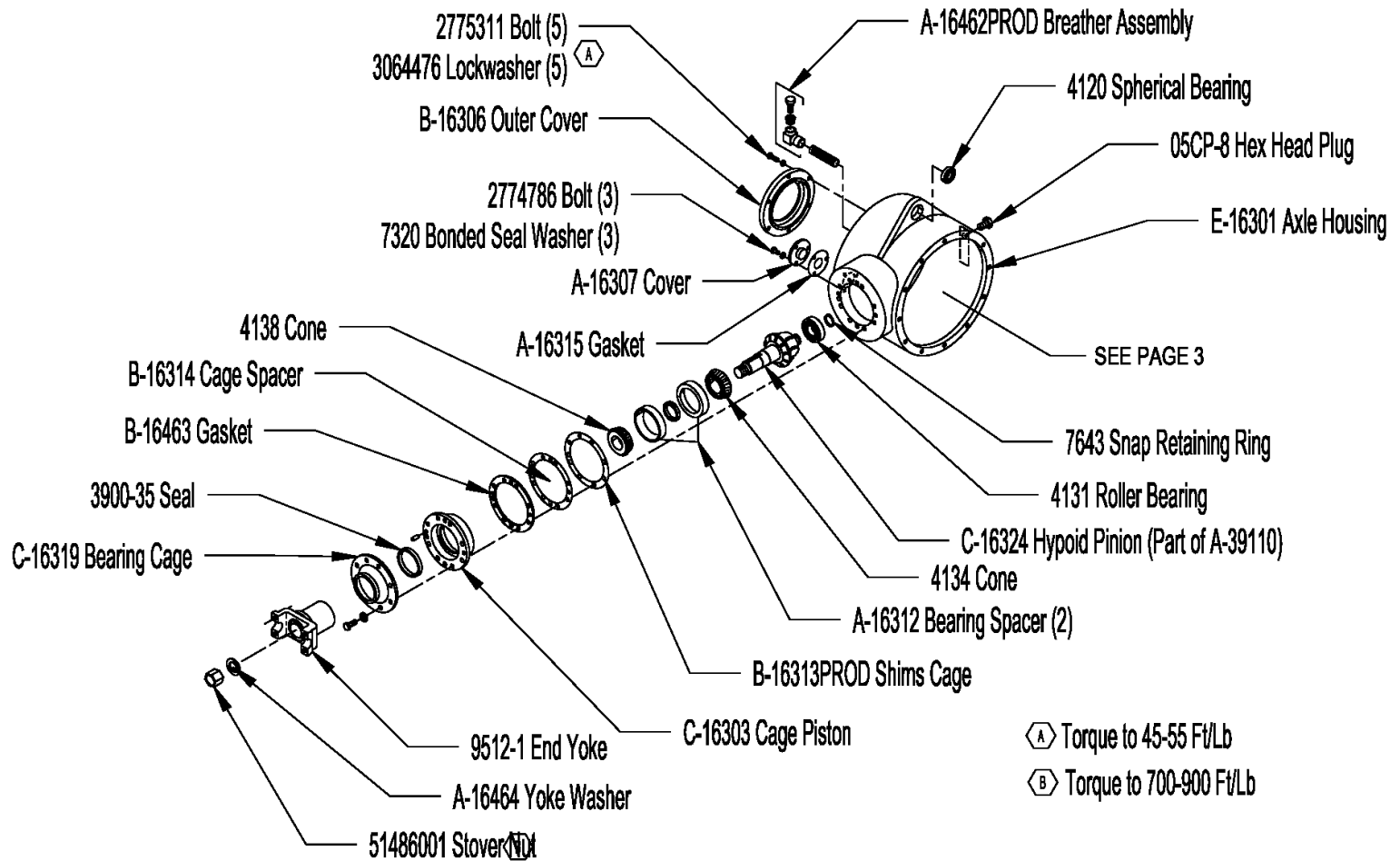


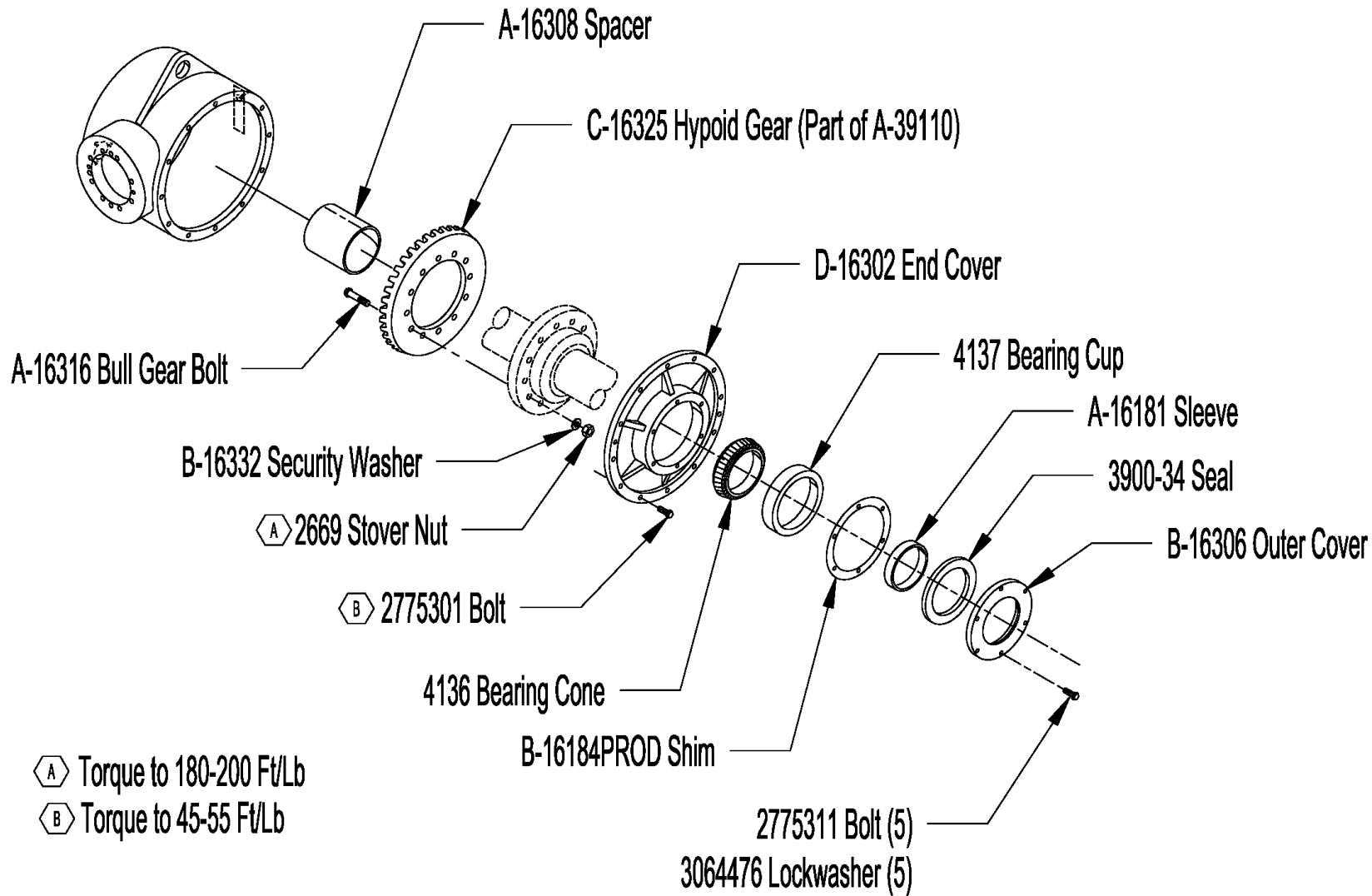
FIGURE 2-1-1. Axles and Drive Housing 35 mph w/24" Demountable Wheels



Not Shown:

Magnetic Plug: 3743
Transducer: 8606

**FIGURE 2-1-1. Axles and Drive Housing
35 mph w/24" Demountable Wheels**



**FIGURE 2-1-2. Axles and Drive Housing
Truck Style Axle**

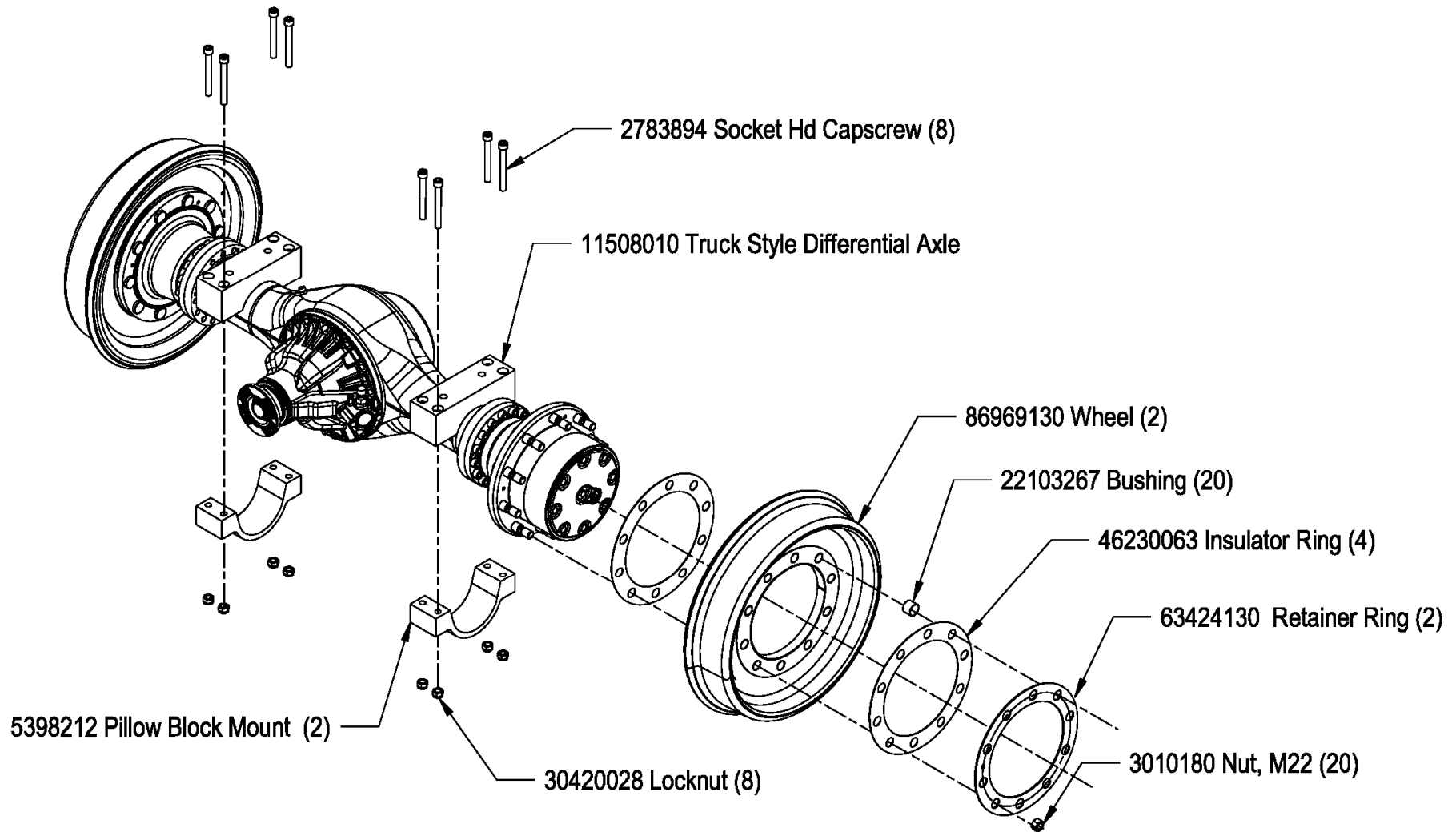
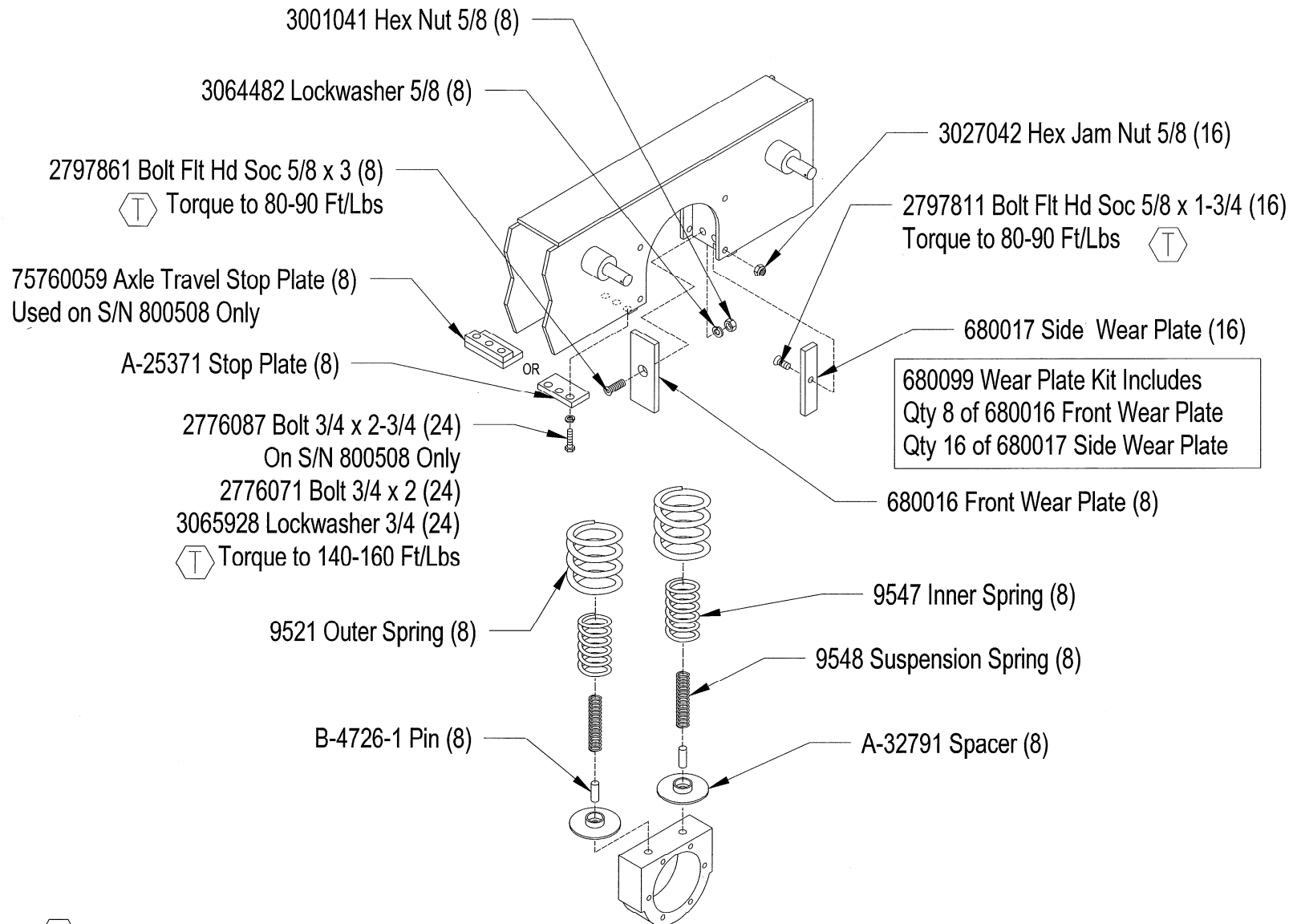
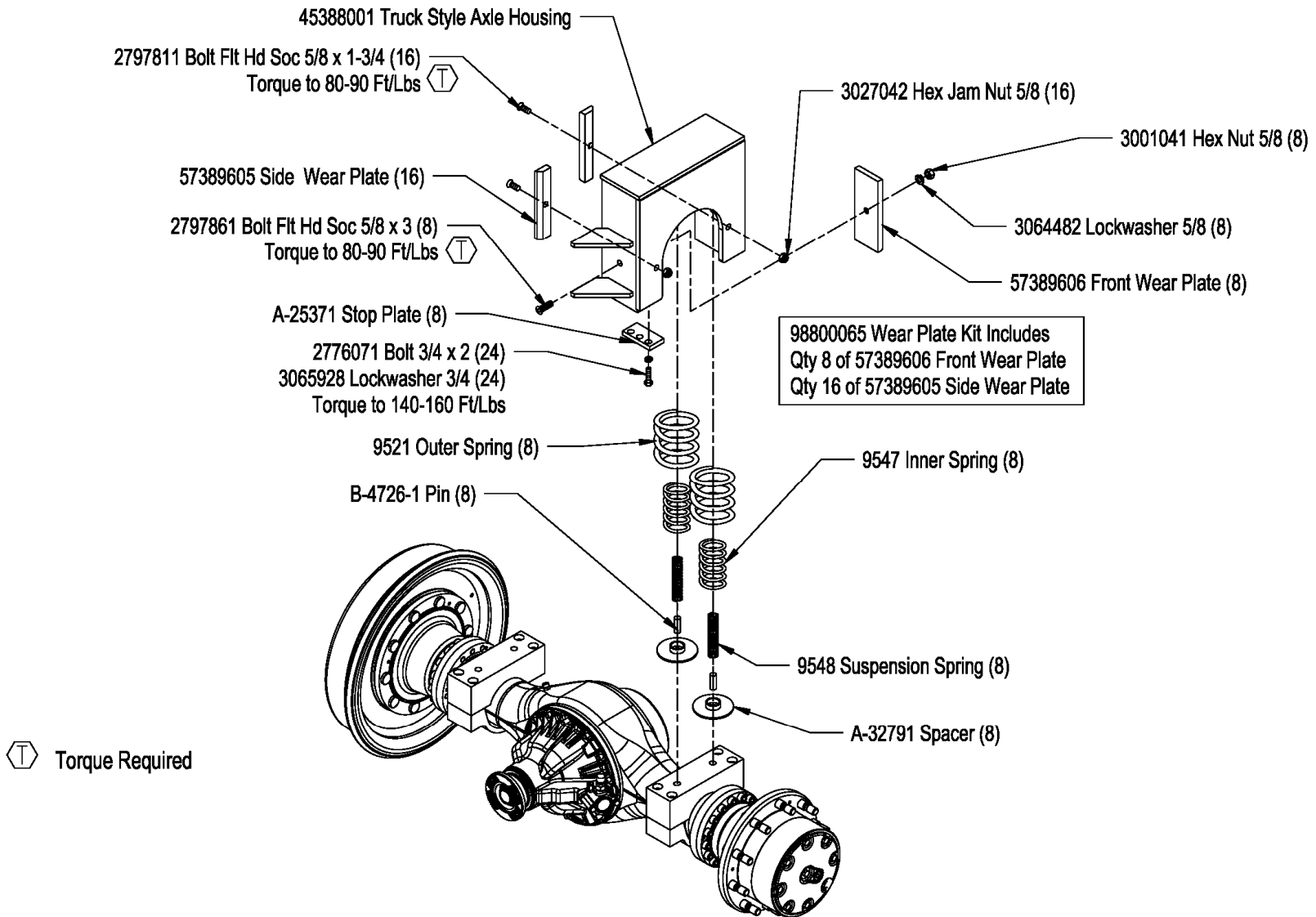


FIGURE 2-2-1. Axles and Drive Housing Standard Axle Suspension

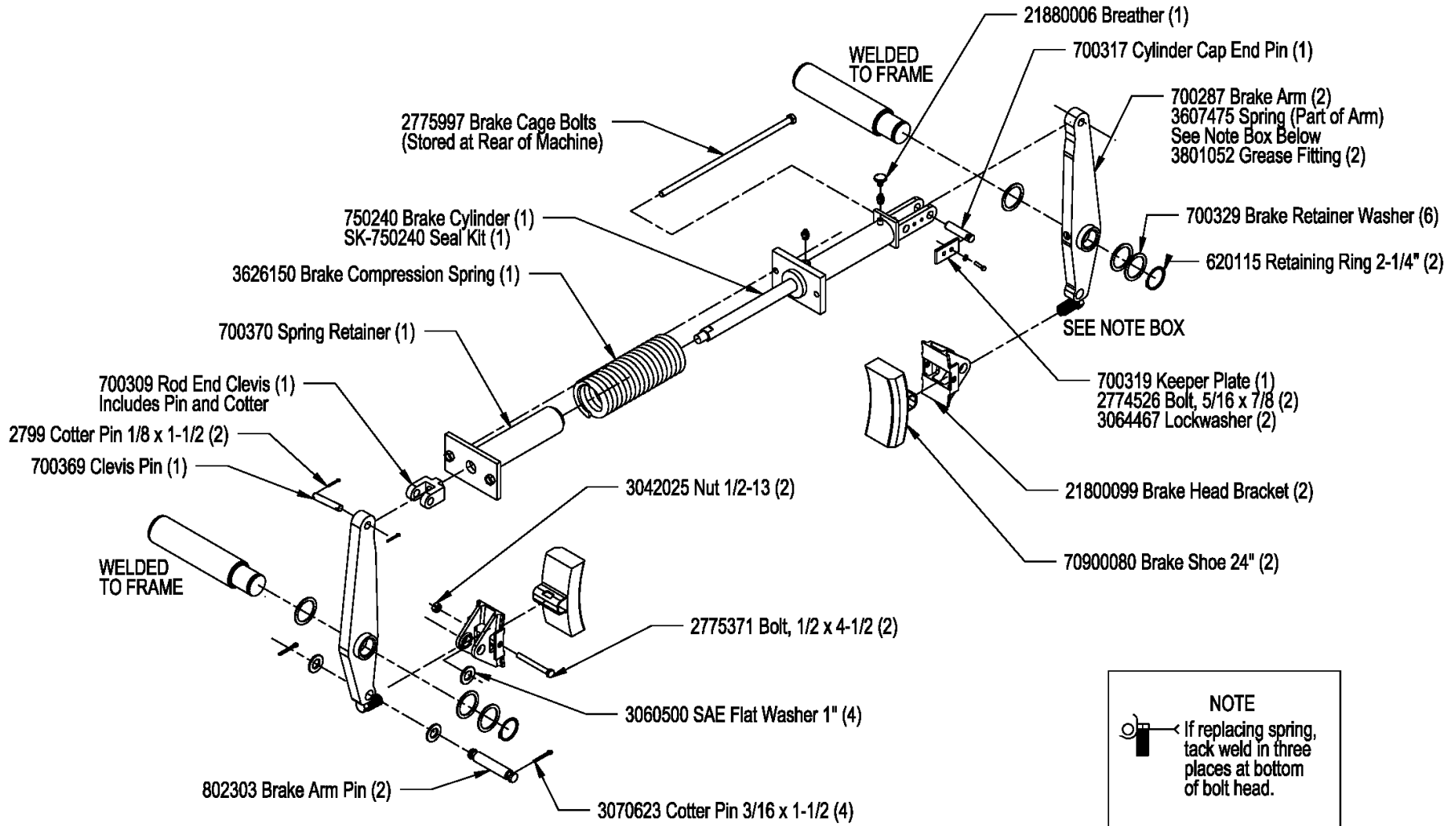



Torque Required

FIGURE 2-2-2. Axles and Drive Housing Truck Axle Suspension (Part of Kit 98800063)

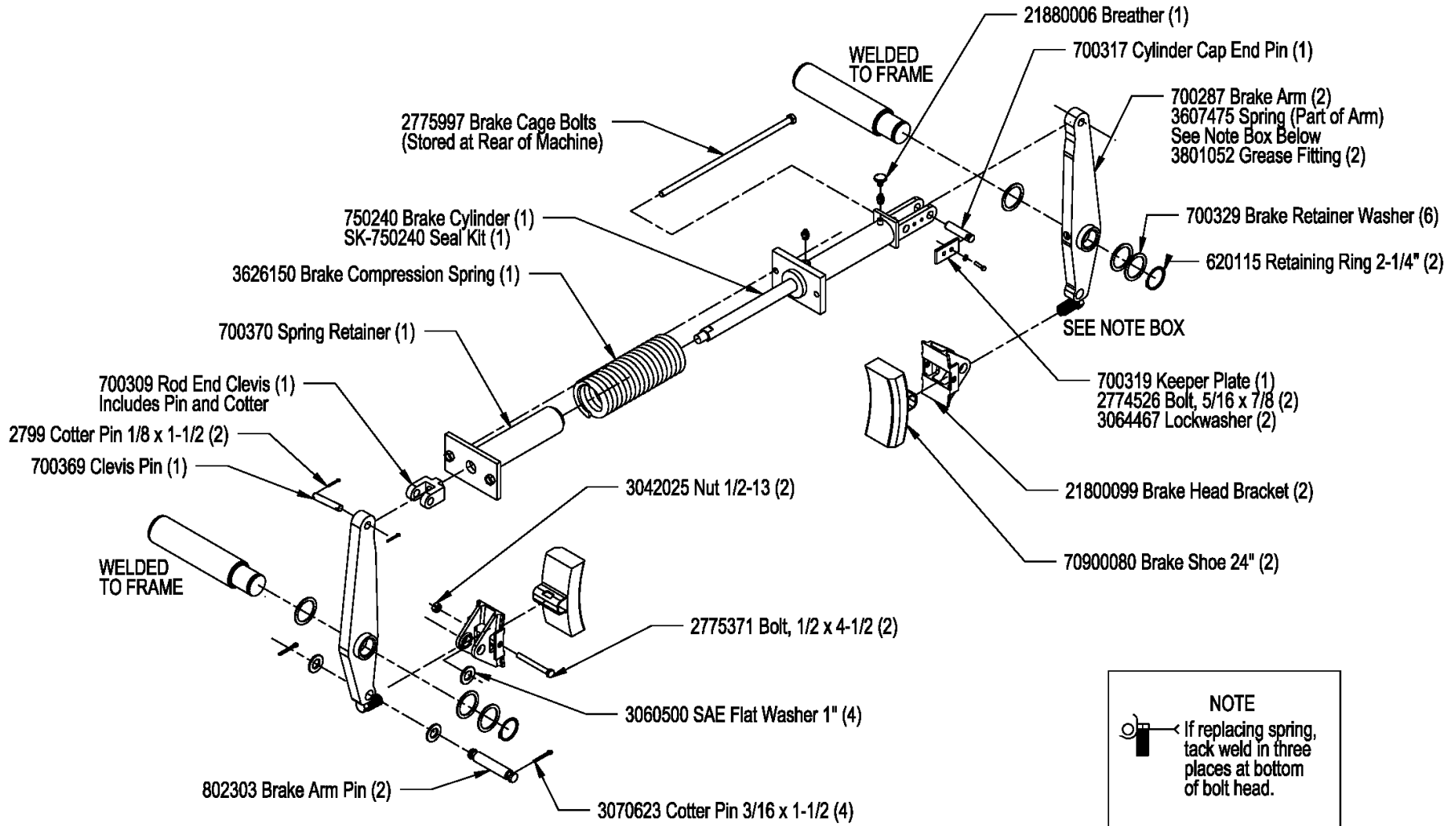



**FIGURE 3-1. HYDRAULIC BRAKES
 Cobra Style**



NOTE
 If replacing spring, tack weld in three places at bottom of bolt head.

**FIGURE 3-1. HYDRAULIC BRAKES
 Cobra Style**



NOTE
 If replacing spring, tack weld in three places at bottom of bolt head.

**FIGURE 5-1. TRANSMISSION
and DRIVESHAFTS
S/N 800300 and Above**

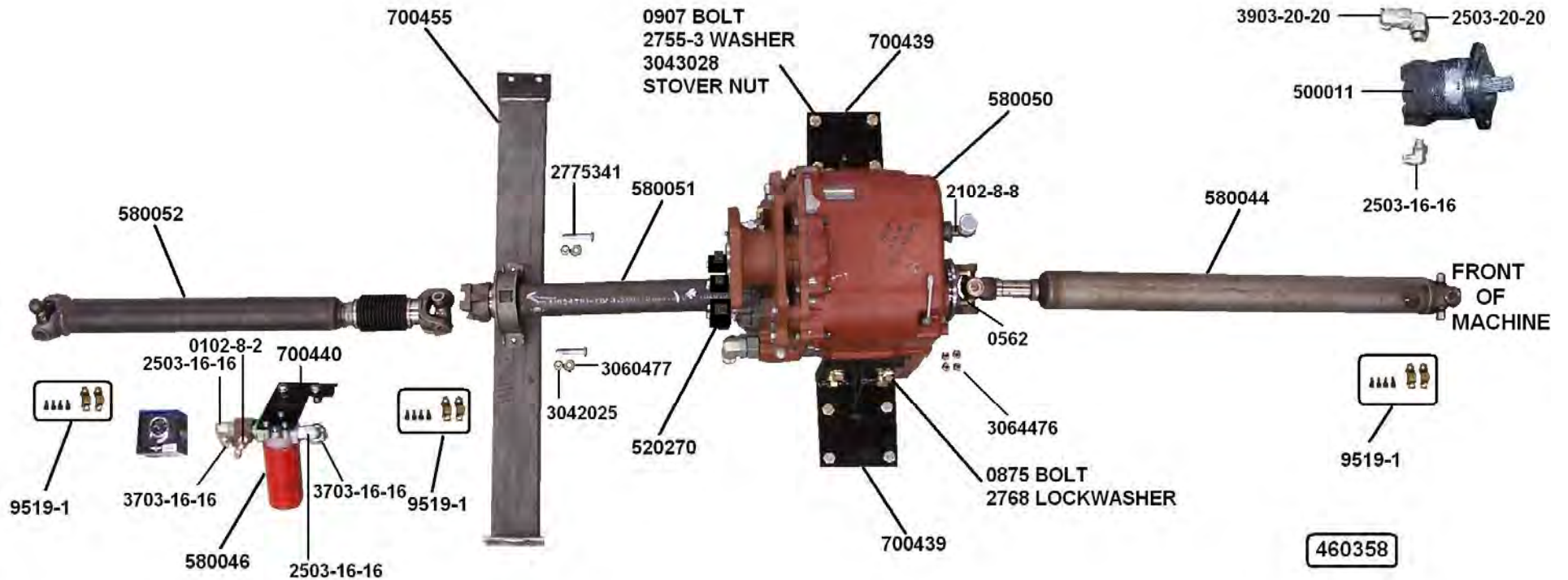
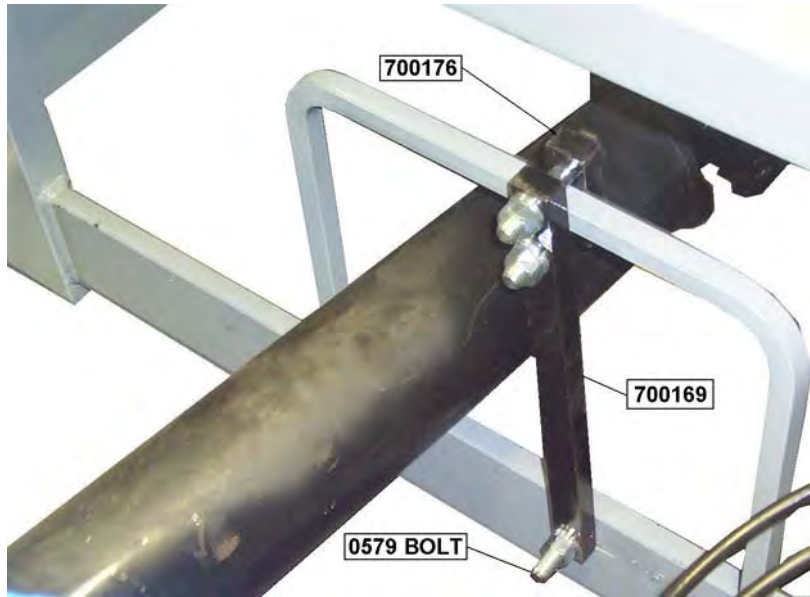


FIGURE 5-1. TRANSMISSION and DRIVESHAFTS S/N 800300 and Above



OPTIONAL DRIVE SHAFT PROTECTION KIT 460121

FIGURE 5-2. TORQUE ARM
S/N 800300 and Above

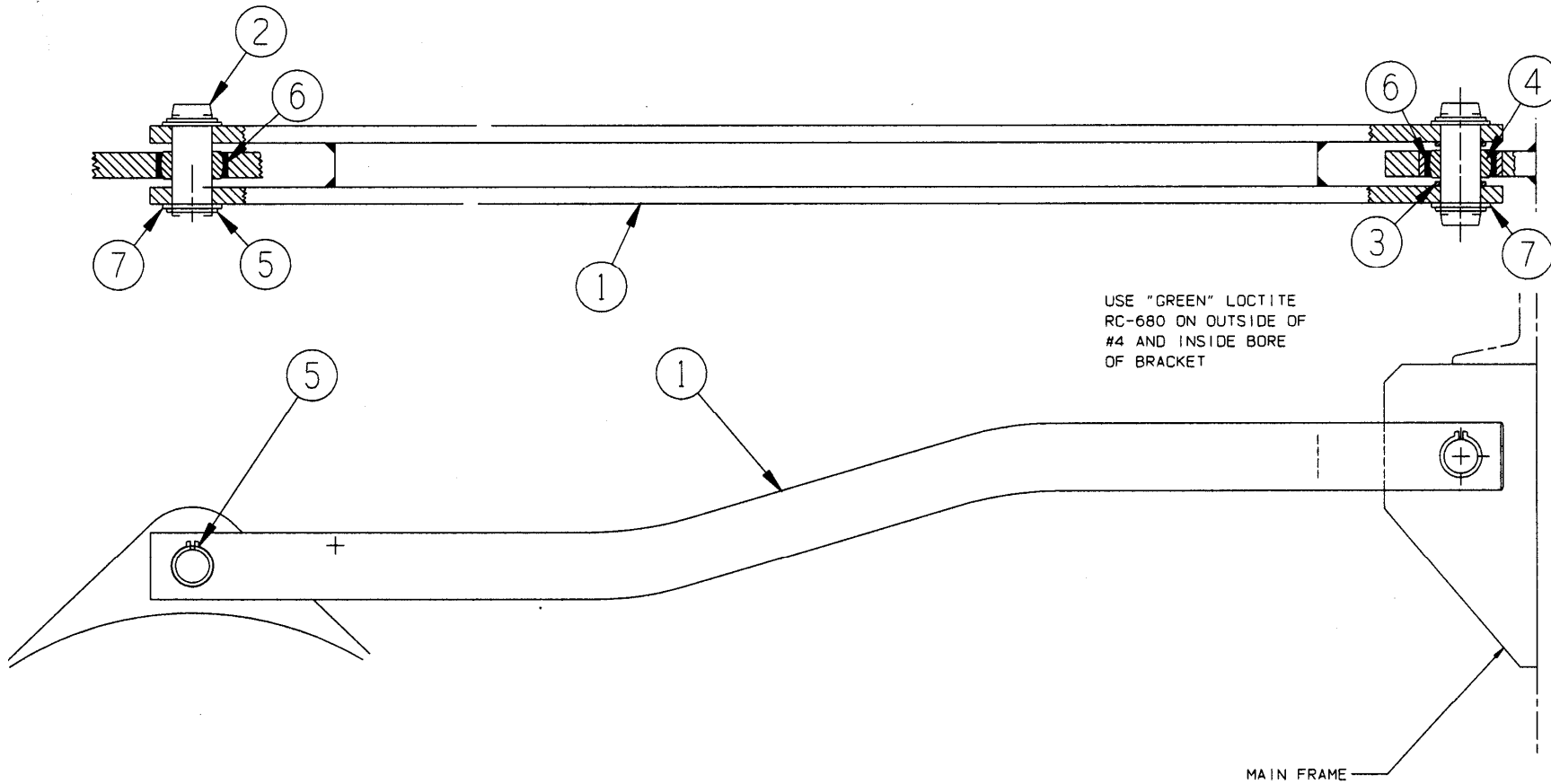
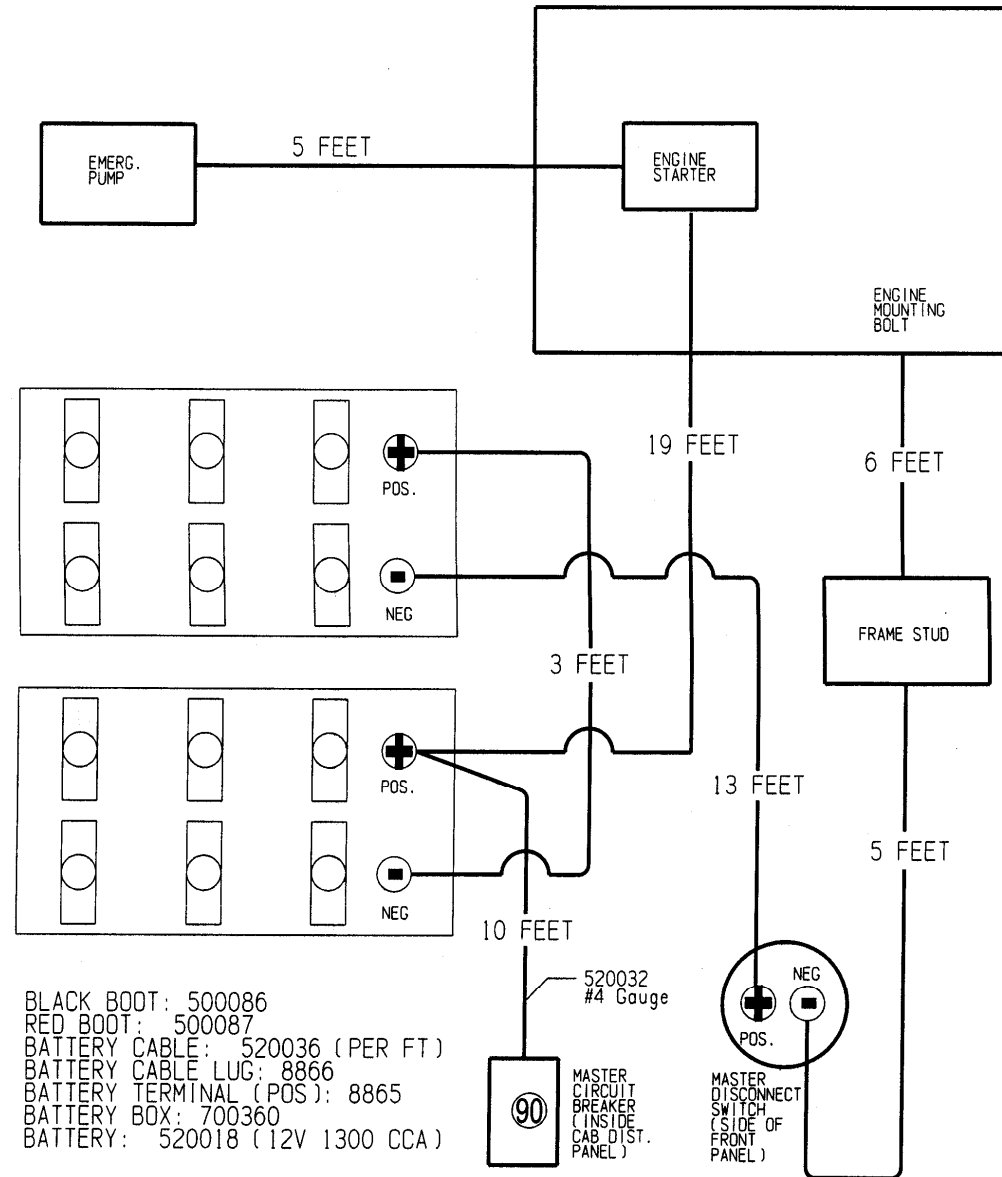


FIGURE 5-2. TORQUE ARM S/N 800300 and Above

ITEM NO.	PART NO.	DESCRIPTION	UNITS PER ASSEMBLY
1A	802063	Curved Torque Arm.....	1
2	B-4726-1	Pin.....	2
3	A-10973	Spacer.....	2
4	4120	Bearing.....	1
5	7641	Retaining Ring.....	4
6	A-27236	Bushing.....	1
7	4731-5	Washer.....	4
1B	B-24939	Straight Torque Arm.....	1
2	B-4726-1	Pin.....	2
3	A-10973	Spacer.....	2
4	4120	Bearing.....	1
5	7641	Retaining Ring.....	4
6	A-27236	Bushing.....	1
7	4731-5	Washer.....	4

FIGURE 6-1. BATTERIES
S/N 800300 and Above



**FIGURE 6-3. RAIL SWEEP
Element Style
S/N 800300 and Above**

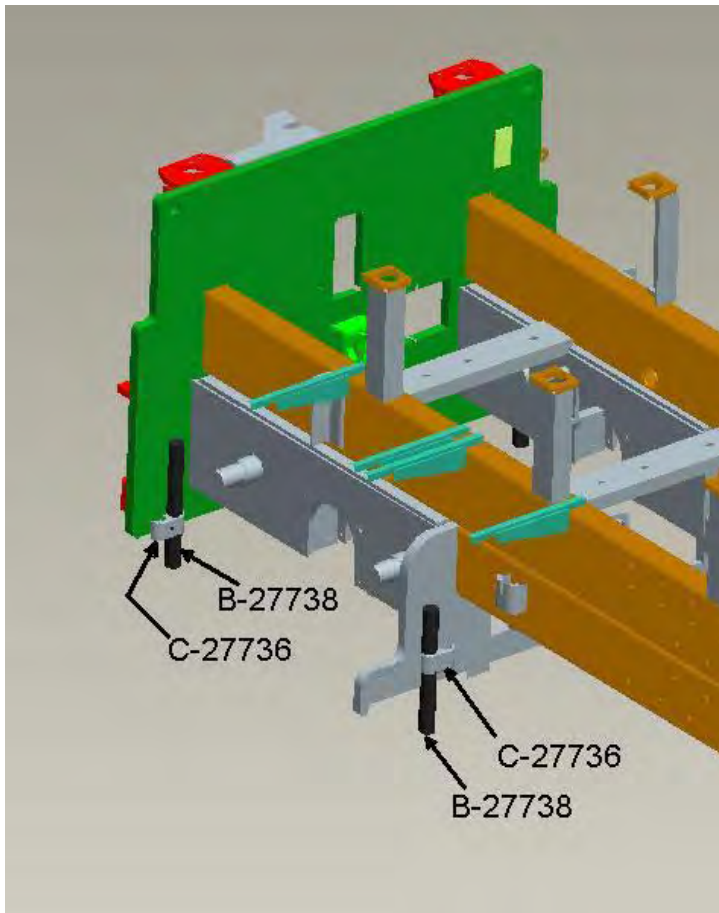


FIG 6-5. STANDARD DECALS (460315)

Seq	Stock code	Qty	U/m	Description	Long description
10	690180	2	EA	DECAL,MACHINE SPECIFICATION M7	
12	690182	2	EA	DECAL,MODEL M7	
14	56403802098	1	EA	BLANK,PATENT PLATE	
16	29300186	2	EA	DECAL,WARNING "HEARING PROTECT	
18	56405131	1	EA	PLAQUE,BATTERY BOX"JUMP START"	
22	810678	2	EA	DECAL,MADE IN CANADA	
24	690177	1	EA	DECAL,LUBE CHART FRONT M7	
26	690178	1	EA	DECAL,LUBE CHART CENTER M7	
28	690179	1	EA	DECAL,LUBE CHART REAR M7	
30	690161	1	EA	DECAL,REAR BRAKE LOCK UP M7	
32	690162	1	EA	DECAL,FRONT BRAKE LOCK UP M7	
100	56357102098	1	EA	PLATE,NAME,BLANK	
102	56420004	8	EA	DECAL,DANGER	"PINCH POINT"
104	56420003	2	EA	DECAL,DANGER REVISION --	"DO NOT CLIMB UNDER"
106	56420012	5	EA	DECAL,LOCKUP POINTS	REVISION --
108	56420001	2	EA	DECAL,CAUTION GENERAL SAFETY	10" X 10" REVISION --
110	56420002	2	EA	DECAL,3 X 5 REVISION--	"CAUTION WATCH YOUR STEP"
112	56420007	2	EA	DECAL,WARNING FOR	EXHAUST EMISSIONS REVISION --
114	A-31369	4	EA	DECAL,JACK HERE	
116	A-31371	4	EA	DECAL,LIFT HERE	
118	810668	1	EA	DECAL,MASTER CIRCUIT BREAKER	REV.# 1850
120	800196	1	EA	DECAL - ENGINE OIL DRAIN	
130	690105	1	EA	DECAL,MACHINE UP MACHINE DOWN	TURNTABLE M2-14
134	690042	2	EA	DECAL,NORDCO,EXTRA LARGE	(7.5 X 22")
136	690158	2	EA	DECAL,NORDCO-MEDIUM	WHITE BACKGROUND
138	29300014	2	EA	DECAL,NORDCO MEDIUM-SIZE	USE DWG 9749 1008
142	56424502	5	EA	DECAL,DISCONNECT BEFORE WELD	TIER 2 ENGINE ECU PROTECTION
142	690181	5	EA	DECAL,CAUTION DISCONNECT	BEFORE WELDING M7
144	810897	2	EA	DECAL,ENGAGE 5TH LINK PRIOR TO	TRAVEL
146	690035	2	EA	DECAL,ETHER WARNING	
150	56420030	4	EA	DECAL,GREASE,CIRCULAR	
151	56420031	13	EA	DECAL,GREASE,RIGHT ARROW	
152	56420032	13	EA	DECAL,GREASE,LEFT ARROW	
153	56420033	22	EA	DECAL,GREASE,DOWN ARROW	
154	56420034	22	EA	DECAL,GREASE,TOP ARROW	
160	802263	1	EA	DECAL,MACHINE EXCEEDS	PLATE-C IN TRAVEL POSITION
162	810839	1	EA	DECAL,PLOW BLADES ARE WIDER	WHEN PARTIALLY EXTENDED
164	56404927	1	EA	PLAQUE,VALVE OPEN/CLOSE	REVISION -
166	690156	2	EA	DECAL, "24 VOLT SYSTEM", 1"	WHITE CAST ARIAL
180	690150	1	EA	DECAL, RIGHT JOYSTICK FUNCTION	DIAGRAM, M7
182	690152	1	EA	DECAL, LEFT JOYSTICK FUNCTION	DIAGRAM, M7
184	690157	1	EA	DECAL, MAIN ELECTRICAL SWITCH	DISCONNECT M7

**FIGURE 7E-1-1. JOHN DEERE ENGINES
John Deere 6068HF – Tier 3
With Clutch Disconnect
S/N 800300 and Above**





FIGURE 7E-1-1. JOHN DEERE ENGINES
John Deere 6068HF – Tier 3
With Clutch Disconnect
S/N 800300 and Above

ITEM NO.	PART NO.	DESCRIPTION	UNITS PER MACHINE
1	600242	Engine, John Deere 6068HF	1
2	600117	. Switch, Temperature	1
3	600118	. Switch, Pressure (12psi)	1
4	600195	. Drive, Triple Pump	1
5	500011	. Pump, Gear	1
6	3890167	. Filter, Primary Fuel (Canister)	1
7	3890210	. Filter, Oil	1
--	35710750	. . Seal, Reusable O-Ring	1
8	3890165	. Separator, Fuel/Water	1
9	3890142	. Filter, Outer Air	1
10	3890144	. Filter, Inner Air	1
11	17560010	. Belt, Serpentine	1
12	37580025	. Alternator	1
13	7087100	. Indicator, Air Restriction	1
14	61231242	. Relay, Intake Heater Small	1
15	61231248	. Relay, Intake Heater 24V Continuous....	1
16	50480870	. Muffler	1
17	37750012	. Governor, Air Compressor	1
18	61200101	Potentiometer, Throttle Control	1
19	802228	Harness, JD Engine	1
20		Dome Light (Optional)	1



FIGURE 7-C1. CUMMINS TIER 3 ENGINE

Cummins Tier 3 Engine

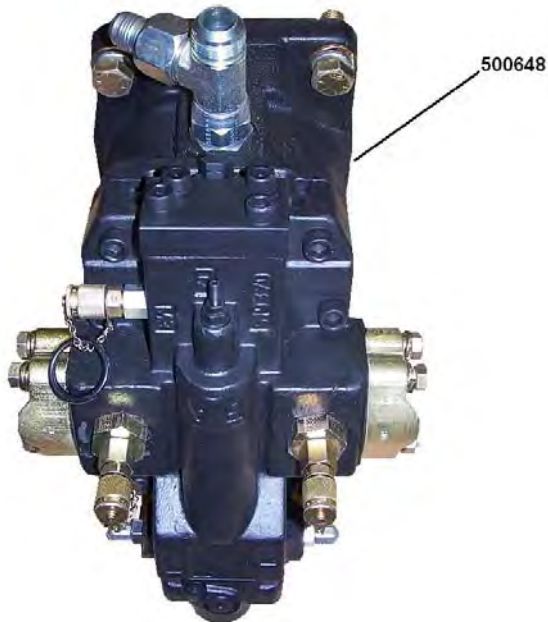
Stock code	Description	Qty	U/m
460450	ASSY,ENGINE CUMMINS TIER 3	1	EA
480147	DRAWING, LIFT LUGS ACCESS	0	EA
600250	ENGINE,CUMMINS QSC8.3 C305	1	EA
600256	ASSY, FILTER COMPRESSOR	1	EA
600257	FILTER, OIL CUMMINS QSC8.3	1	EA
600258	FILTER, FUEL CUMMINS QSC8.3	1	EA
600259	FILTER, FUEL WATER SEPARATOR	1	EA
600260	FILTER, AIR OUTER	1	EA
600261	FILTER, AIR INNER	1	EA
600262	STARTER MOTOR, CUMMINS QSC 8.3	1	EA
600263	ALTERNATOR, 24V 140 A	1	EA
0779	= "BOLT HEX. HD. 5/8"-11 x 2"	4.00	EA
3060045	WASHER,HARDEND FLAT 5/8 X 1.75	8	EA
3042028	LOCNUT HEX 5/8-11	4	EA
A1***** *	***** ASSY 1 *****	0	EA
0102-8-4	REDUCER PIPE THREAD	1	EA
2102-8-8	ADAPTER	1	EA
01CP-4	ADAPTER	1	EA
3799-41	COUPLER, BRASS	2	EA
802250	HOSE,A/C SUCTION M2-14	1	EA
802251	HOSE,A/C PRESSURE M2-14	1	EA
802252	HOSE,A/C TO DRIER M2-14	1	EA
A2***** *	***** ASSY 2 *****	0	EA
500818	PUMP, GEAR 2.46 CU IN /REV	1	EA
2080685	ELBOW,45DEG -20 O-RING/FLARE	1	EA
A3***** *	***** ASSY 3 *****	0	EA
2080460	ELBOW,FLARE/O-RING MALE 10	1	EA
E*****	***** ELECTRICAL *****	0	EA
520036	CABLE,BATTERY 3/0 SIZE	2	FT
8866	LUG, BATTERY CABLE	2	EA

Cummins Tier 3 Engine

Stock code	Description	Qty	U/m
520311	HARNESS, CUMMINS TIER 3 ENGINE	1	EA
520319	HARNESS, OEM POWER TIER 3	1	EA
520036	CABLE,BATTERY 3/0 SIZE	3	FT
8866	LUG, BATTERY CABLE	2	EA
690220	DECAL, ENGINE DIAGNOSTICS	1	EA
5125472	SWITCH,NGR ROCKER (BASE)	1	EA
520036	CABLE,BATTERY 3/0 SIZE	6	FT
8866	LUG, BATTERY CABLE	2	EA
520032	CABLE,#4 GAUGE BATTERY	78	IN
8896	WIRE TERMINAL PANDUIT	1	EA
8889	LUG, PANDUIT	1	EA
F*****	***** FRAME ATTACH *****	0	EA
2775321	= "CPSCR HX .50-13 X 2"	6	EA
3042020	LOCNUT HEX 3/8-16	1	EA
1484-30	BOLT,HEX HD 12MM 1.75 X 25MM	1	EA
3060476	WASHER SAE .500	1	EA
M***** *	***** MISC *****	0	EA
680012	ANTIFREEZE,HEAVY DUTY	0	L
29300027	DECAL,ECM SHUTDOWN NOTICE	1	EA
10213818	SPLINE,ADAPTOR PUMP ENG CUMMIN	1	EA
96800024	ASSY,REMOTE DRAIN ENGINE OIL	1	EA
1606982	VALVE,BALL 3/4 NPT LOCKABLE	1	EA
1558644	PLUG,PIPE 3/4 SQHD	1	EA
44253960	HOSE,5/8 ID W/#12 FEM SWVL	1.00	EA
3875	HOSE CLAMP GEAR-TYPE	1.00	EA
1971550	= "ADPT,BULKHEAD-12 TO 3/4" NPT"	1	EA



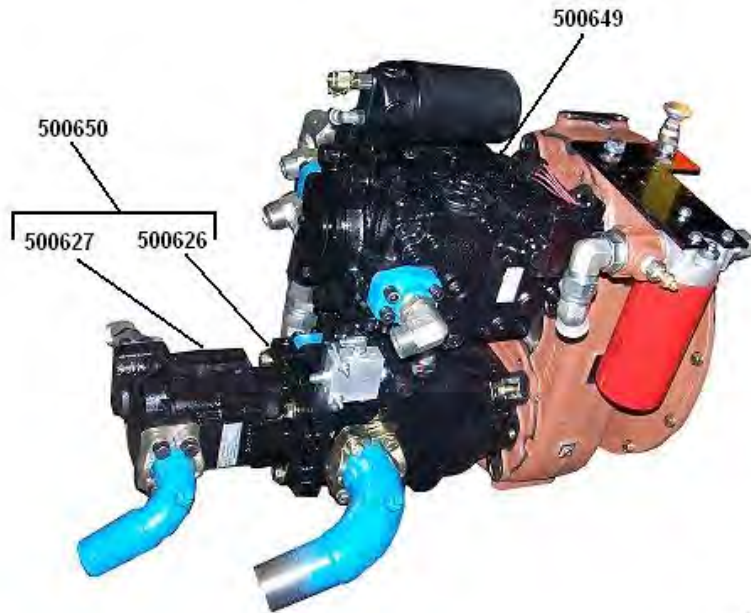
FIGURE 7-C1. CUMMINS TIER 3 ENGINE



QTY	DESCRIPTION	UNIT	PRICE	EA
35	000400 A4*****	**** ASSY 4 *****		0.00 EA
36	000405 500649	PUMP,90 SERIES 100 CC	M7 TRACK DRIVE 4640 PSI	1.00 EA
37	000410 2775301	BOLT HEX. HD. 1/2"-13 x 1-1/2"	Plated Grade 5	4.00 EA
38	000412 3060477	WASHER FLAT 1/2" ALLOY	DI Chromate Alloy	4.00 EA
39	000414 3505	PLUG, DRYSEAL 1/8"		2.00 EA
40	000416 053T-12-12	TEE RUN STR. THREAD	12 R50X-S (10/Pkg.)	1.00 EA
41	000418 2076239	CONNECTOR STRAIGHT THREAD	6 F50X-S (5/PKG.)	1.00 EA
42	000422 N-047	4 BOLT FLANGE		1.00 EA
43	000424 FF1868T1616S	ADAPTER,ORING TO ORS #16	TRACK DRIVE HOSES M2-14	1.00 EA
44	000426 0503-20-20	CONNECTOR STRAIGHT THREAD	20 F50X-S (5/Pkg.)	1.00 EA
45	000455 10288604	STAUFF,TEST COUPLING (MALE)	WITH SAFETY CAP	1.00 EA
46	000458 0510-6-4	ADAPTER		1.00 EA
47	000482 500771	HOSE, TRACK DRIVE	NO DISCONNECT M7	2.00 EA
48	000484 HE20101JCJD1LCX	ASSY,HOSE SUCTION TRACK DRIVE	M2-14 NO CLUTCH	1.00 EA
49	000500 A5*****	**** ASSY 5 *****		0.00 EA

FIGURE 7P-1. PUMPS

MAIN CONTROL PUMP



	A	B	C	D	E	F
1	PUMP ASSEMBLY					
2	Sequence	Stock code	Description	Long description	Quantity per	U/m
3	000092	802286	DECAL,CAUTION PRIOR TO TRAVEL		1.00	EA
4	000200	A1*****	***** ASSY 1 *****		0.00	EA
5	000202	500650	PUMP,DOUBLE SERIES 45 FRAME E	WITH REAR GEAR	1.00	EA
6	000220	HE40074XXX1LCX	HOSE, SUCTION 2-1/2 X 74" LG		1.00	EA
7	000222	N-061	SPLIT FLANGE KIT 2 1/2 CODE 61		1.00	EA
8	000224	F-689	CLAMP,HOSE 73-79MM MIKALOR		2.00	EA
9	000226	6373-5	SPLIT FLANGE HOSE BARB 90 ELBO	DMIC #SBE-2500	1.00	EA
10	000228	3637	PLUG - 1/4" NPT SQ. HEAD		1.00	EA
11	000230	3391	COUPLING, 1/4" NPT HALF		1.00	EA
12	000232	2503-4-6	ADAPTER		1.00	EA
13	000234	2503-12-12	ELBOW,90 DEG O-RING/FLARE -12		1.00	EA
14	000236	500673	FLANGE,4 BOLT 1-1/4 SAE	CODE 62	1.00	EA
15	000238	2503-20-20	ELBOW,90 DEG O-RING/FLARE -20		1.00	EA
16	000240	HE20063JCJD1KCX	ASSY,HYD HOSE #20 63"LG		1.00	EA
17	000253	500770	FLANGE,SPLIT 1-1/2 CODE 61		1.00	EA
18	000254	6373-3	SPLIT FLANGE, HOSE BARB 2"	SPLT FLNG 1-1/2" 90 DEG ELBOW	1.00	EA
19	000255	500769	FLANGE, 4 BOLT 1-1/4 SAE	CODE 61	1.00	EA
20	000256	053T-16-16	RUN TEE STRAIGHT THREAD	16 R50X-S (2/Pkg.)	1.00	EA
21	000258	221501-16-6	ADAPTER - REDUCING		1.00	EA
22	000262	10288608	COUPLING,MALE/FEMALE #6 FLARE	STAUFF	1.00	EA
23	000266	3897	CLAMP, MIKALOR	59-63	2.00	EA
24	000300	A3*****	***** ASSY 3 *****		0.00	EA
25	000302	54218493	VALVE,DE-STROKE 24V	Refer Part Sales to OAK CREEK	1.00	EA
26	000304	05CP-6	PLUG,HEX HEAD 3/8 ORB	6 P50N-S (100/Pkg.)	1.00	EA
27	000306	2076239	CONNECTOR STRAIGHT THREAD	6 F50X-S (5/PKG.)	2.00	EA
28	000308	2080440	ELBOW 90 DEGREE STR. THREAD	6 C50X-S (10/Pkg.)	1.00	EA
29	000316	700213	BRACKET,PUMP UNLOAD VALVE		1.00	EA
30	000317	1484-27	BOLT, HEX M10 - 1.5 X 25MM	METRIC	1.00	EA
31	000318	2779-3	WASHER LOCK 10MM	Plated Grade 5	1.00	EA
32	000319	2774321	BOLT HEX. HD. 1/4"-20 x 2"	Plated Grade 5	2.00	EA
33	000320	3060464	WASHER FLAT 1/4" SAE	Plated Grade 5	2.00	EA
34	000322	2656	NUT STOVER 1/4"-20	Plated Grade 5	2.00	EA

460340

FIGURE 8-1. HYDRAULIC TANK
S/N 800300 and Above

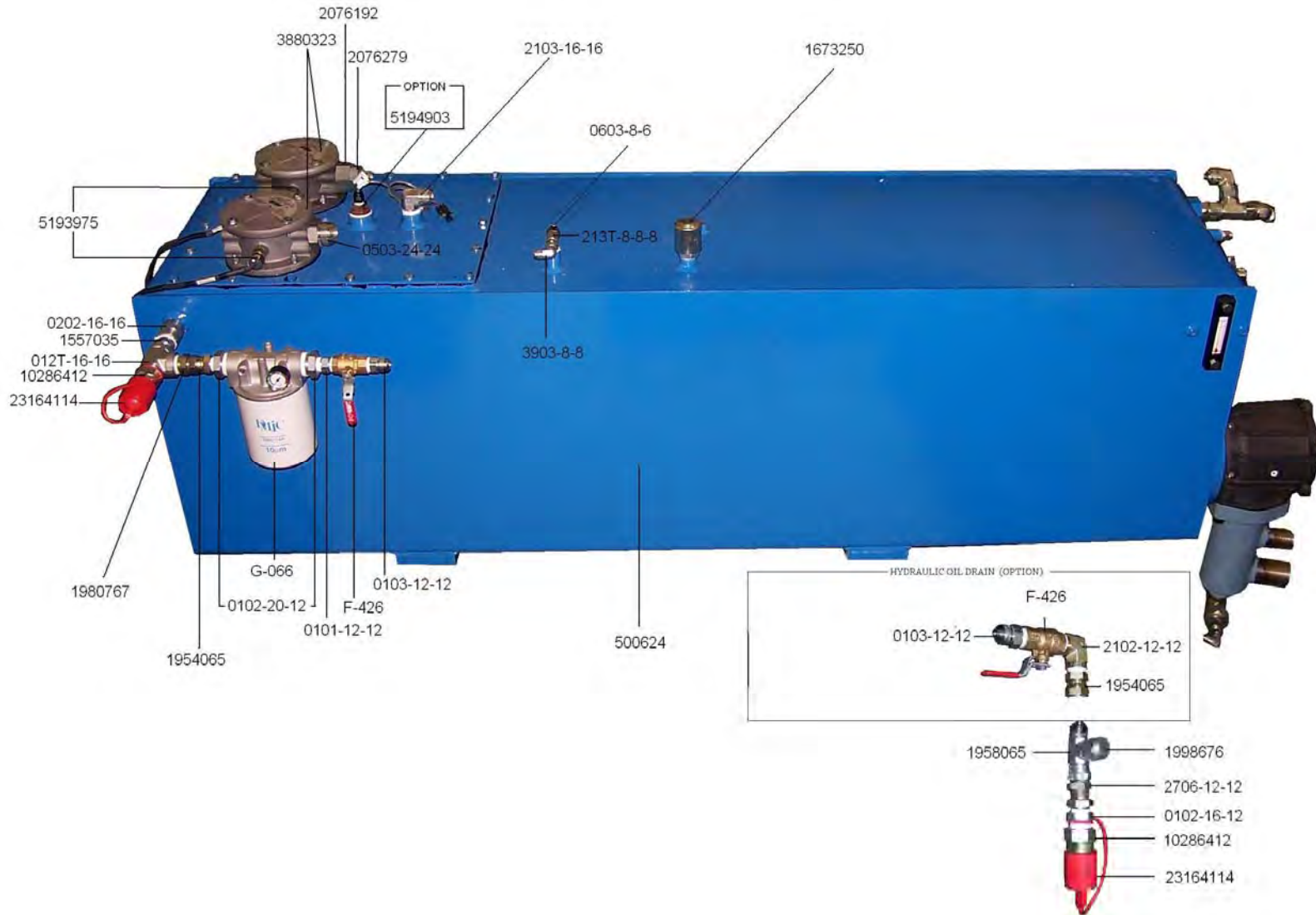
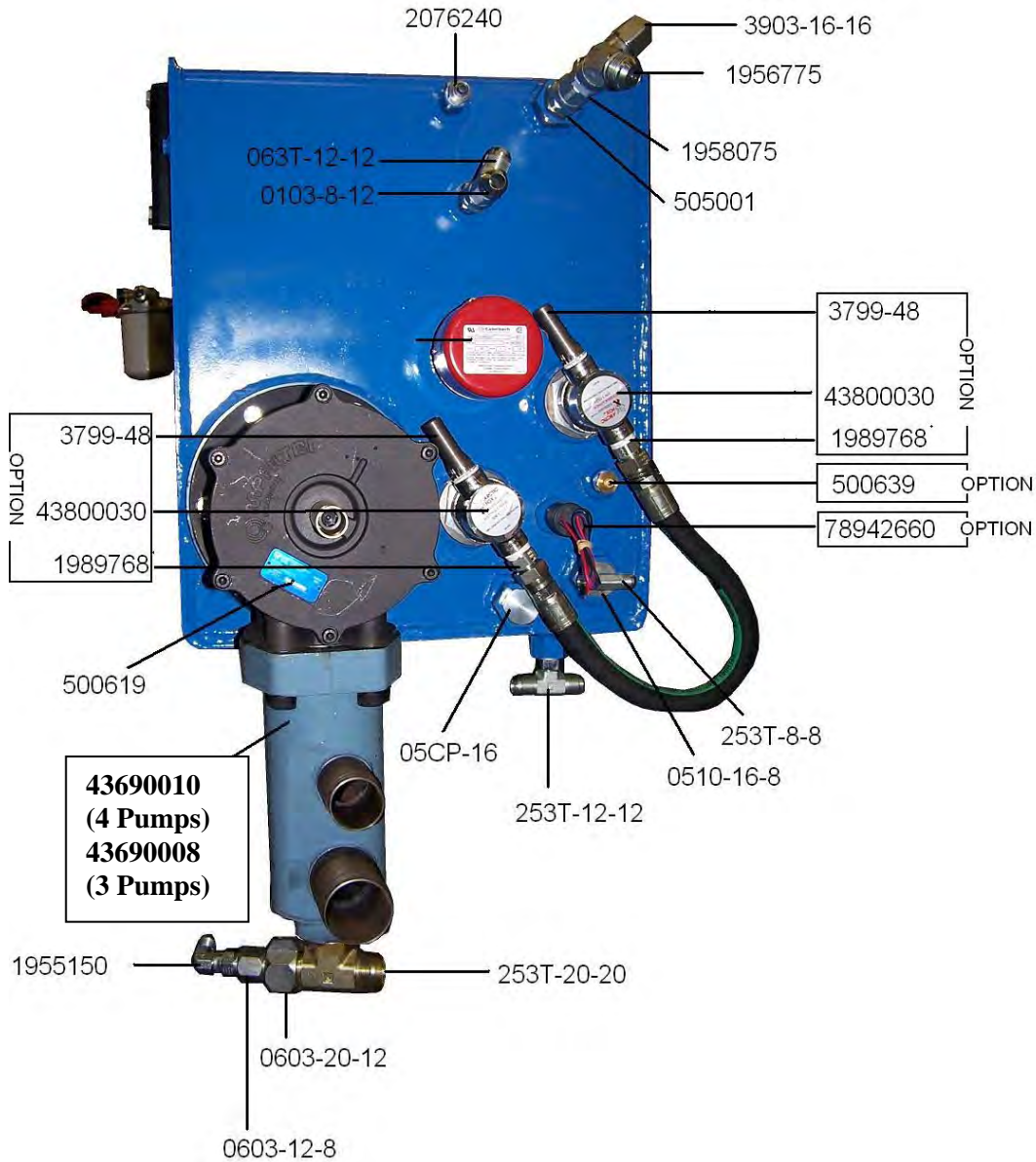
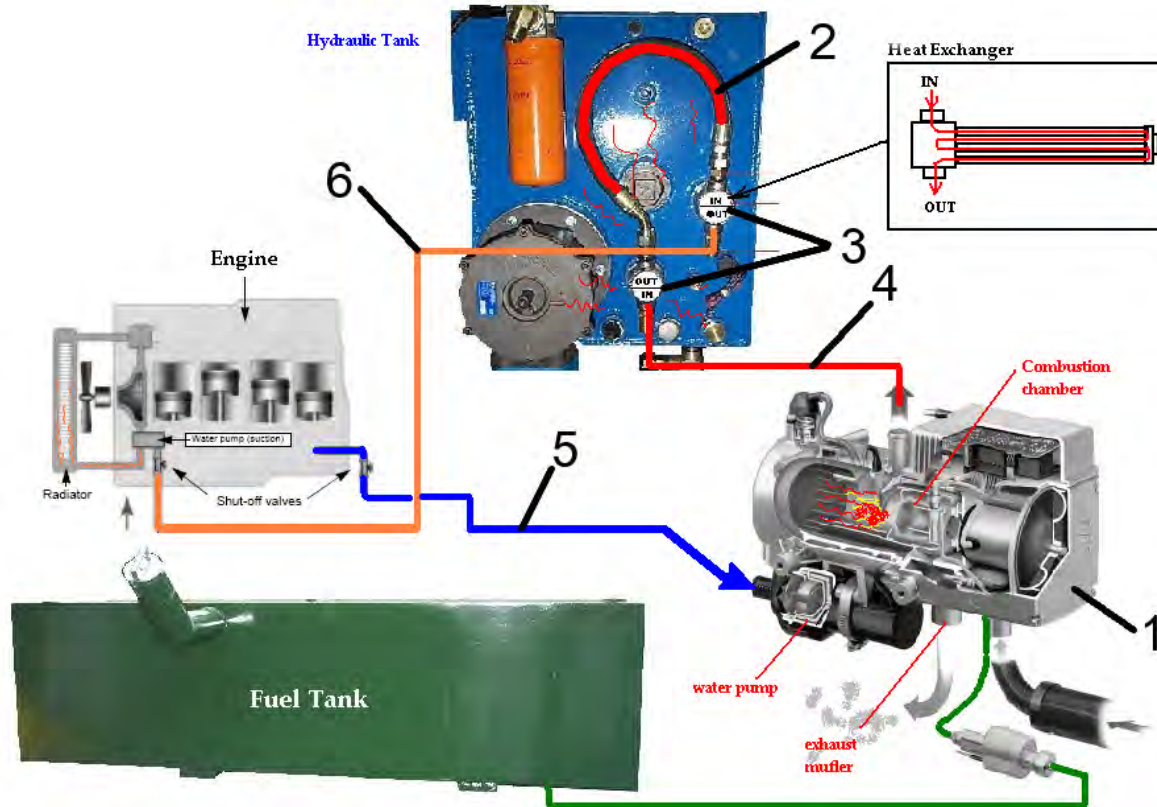


FIGURE 8-1. HYDRAULIC TANK
S/N 800300 and Above



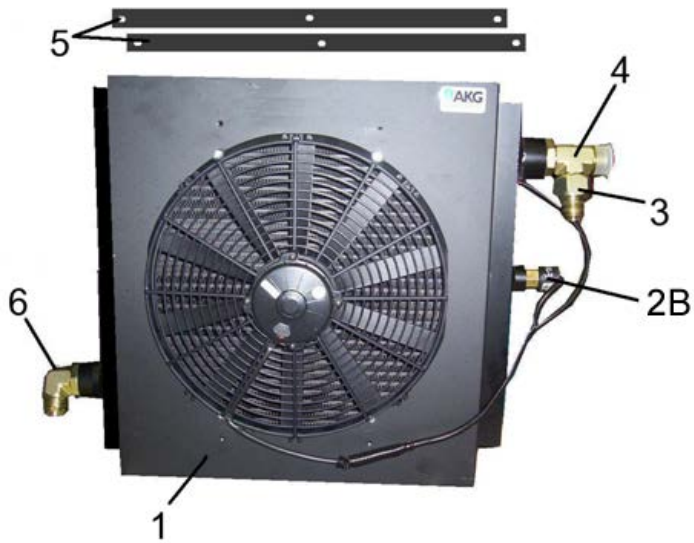
**FIGURE 8-1-1. HYDRAULIC TANK
ESPAR HEATER
S/N 800300 and Above**



**Refer to Fig 8-1 for updated
hyd tank photo**

ITEM NO.	PART NO.	DESCRIPTION	UNITS PER MACHINE
1	8986	Espar Heater	1
2	K-010	Hose	1
3	8854	Heat Exchanger (Thermal Liner)	2
4	GH663-12	Hose	1

FIGURE 9-1. HYDRAULIC OIL COOLER S/N 800300 and Above

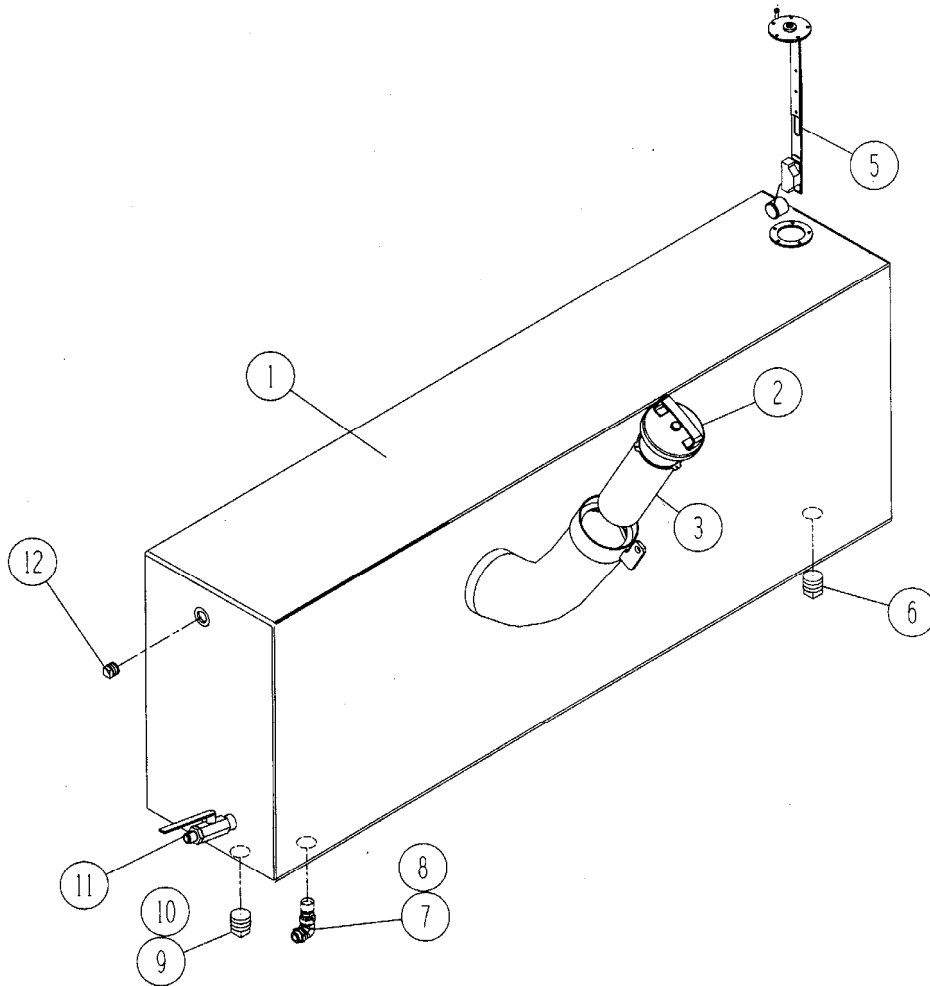


ITEM NO.	PART NO.	DESCRIPTION	UNITS PER MACHINE
1	500385	Hydraulic Oil Cooler	1
--	500383	. . Cooler Core	1
--	500384	. . Cooler Fan.....	1
2	660121	Controller Kit.....	1
2A	96391051	. . Controller.....	1
2B	7022557	. . . Temperature Sensor	1
2C*	2076046	. . Adapter #8 to #6.....	1
3	0603-20-16	Reducing Adapter.....	1
4	053T-20-20	Tee Adapter	1
5	802337	Cooler Mount Flat.....	2
6	2503-20-20	90° Elbow	1
7*	802335	Removable Cooler Mount	1

Mounting hardware:

10	0339	3/8" x 2 Bolt	8
11	2735	3/8" SAE Washer	8
12	2762	3/8" Lockwasher.....	8
13	2506	3/8" Nut.....	8

FIGURE 10-1. FUEL TANK
S/N 800300 and Above

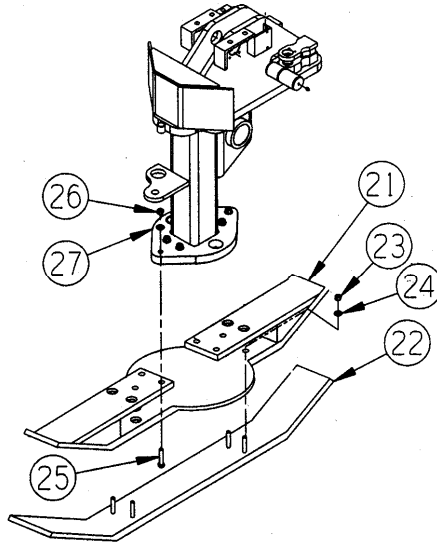


ITEM NO.	PART NO.	DESCRIPTION	UNITS PER MACHINE
1	700368	Fuel Tank 150 Gallon.....	1
2	22840030	Fuel Filler Cap.....	1
3	6090178	Fuel Filler Strainer.....	1
4*	2503-8-8	90° Elbow (Used on Item 11).....	2
5	810647	Fuel Sender	1
6	05CP-6	Hex Head Plug.....	1
7	2503-8-8	Elbow	1
8	06CP-8	Cap	1
9	1980765	Connector	1
10	06CP-12	Cap	1
11	F-426	Ball Valve	1
12	05CP-8	Hex Head Plug.....	1
13*	A-31372	Diesel Fuel Specification Decal	1

Mounting Hardware (not shown):

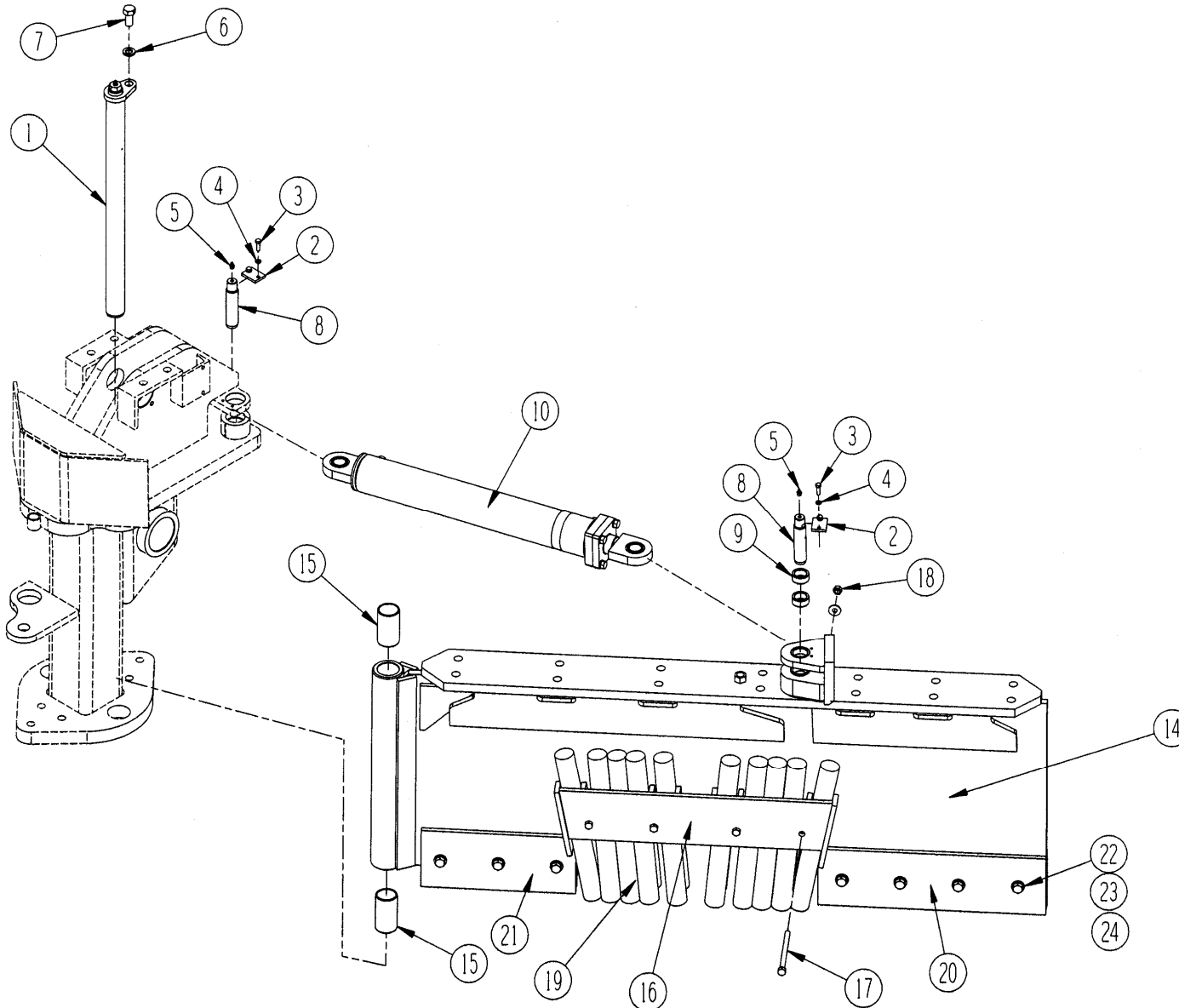
15	771	Hex Bolt, 5/8 x 1-1/2 Grade 8	4
16	2766	Lockwasher.....	4
17	2755-2	Flat Washer.....	4

FIGURE 11-1. FRONT PLOW TIE JUMPERS S/N 800300 and Above



ITEM NO.	PART NO.	DESCRIPTION	UNITS PER MACHINE
--	800069	BTI Tie Jumper Assembly	1
21	840151	. Tie Jumper Adapter.....	1
22	840152	. Front Skid Shoe	1
23	3042025	. 1/2" Hex Nut	4
24	3060477	. 1/2" Flat Washer.....	4
25	2453	. 3/4 x 4-1/2 Hex Capscrew	6
26	3042028	. 3/4" Nut.....	6
27	2755-3	. 3/4 Flat Washer	6

FIGURE 11-2-1. FRONT PLOW
Left Ballast Plow
S/N 800300 Only



**FIGURE 11-2-1. FRONT PLOW
Left Ballast Plow
S/N 800300 Only**

ITEM NO.	PART NO.	DESCRIPTION	UNITS PER MACHINE
1	A-40548	Plow Hinge Rod.....	1
2	A-5200-61	Keeper Plate.....	2
3	2774531	Capscrew 5/16 x 1.....	4
4	2761	5/16" Lockwasher.....	4
5	3004	Fitting, Grease.....	3
6	2768	Washer.....	1
7	0875	Bolt.....	1
8	810491	Pin, Cylinder Pivot.....	2
9	860535	Bushing, Cylinder Pivot.....	8
10	7500-120	Cylinder.....	1
--	SK-7500-98	. . Seal Kit.....	1
11	3895	Clamp, Support.....	4
12	0335	Bolt, Hex 3/8 x 1-3/4.....	1
13	2735	Washer, 3/8".....	1
14	700294	Plow Blade.....	1
15	A-25077	Bushing.....	2
16	860310	Element Clamp.....	2
17	0615	Bolt, 1/2 x 6.....	4
18	3042025	Nut, Stover.....	4
19A	B-40792	Plow Element (Derby).....	20
19B	B-40791	Plow Element (U-Nova).....	20
19C	B-27738	Plow Element (Polyco).....	20
20A	A-40323	Blade, 4-Hole (Standard).....	2
20B	840166	Blade, 4-Hole (BTI/Nordco) 1/2".....	2
20C	840167	Blade, 4-Hole (BTI/Nordco) 3/4".....	2
21A	A-25095	Blade, 3-Hole (Standard).....	2
21B	840164	Blade, 3-Hole (BTI/Nordco) 1/2".....	2
21C	840165	Blade, 3-Hole (BTI/Nordco) 3/4".....	2
22	0805	Bolt, Hex 5/8 x 3-1/2.....	7
23	2668	Nut, Stover 5/8.....	7
24	2755-2	Washer, 5/8.....	14

**FIGURE 11-2-1A. FRONT PLOW
Left Ballast Plow
S/N 800301 and Above**

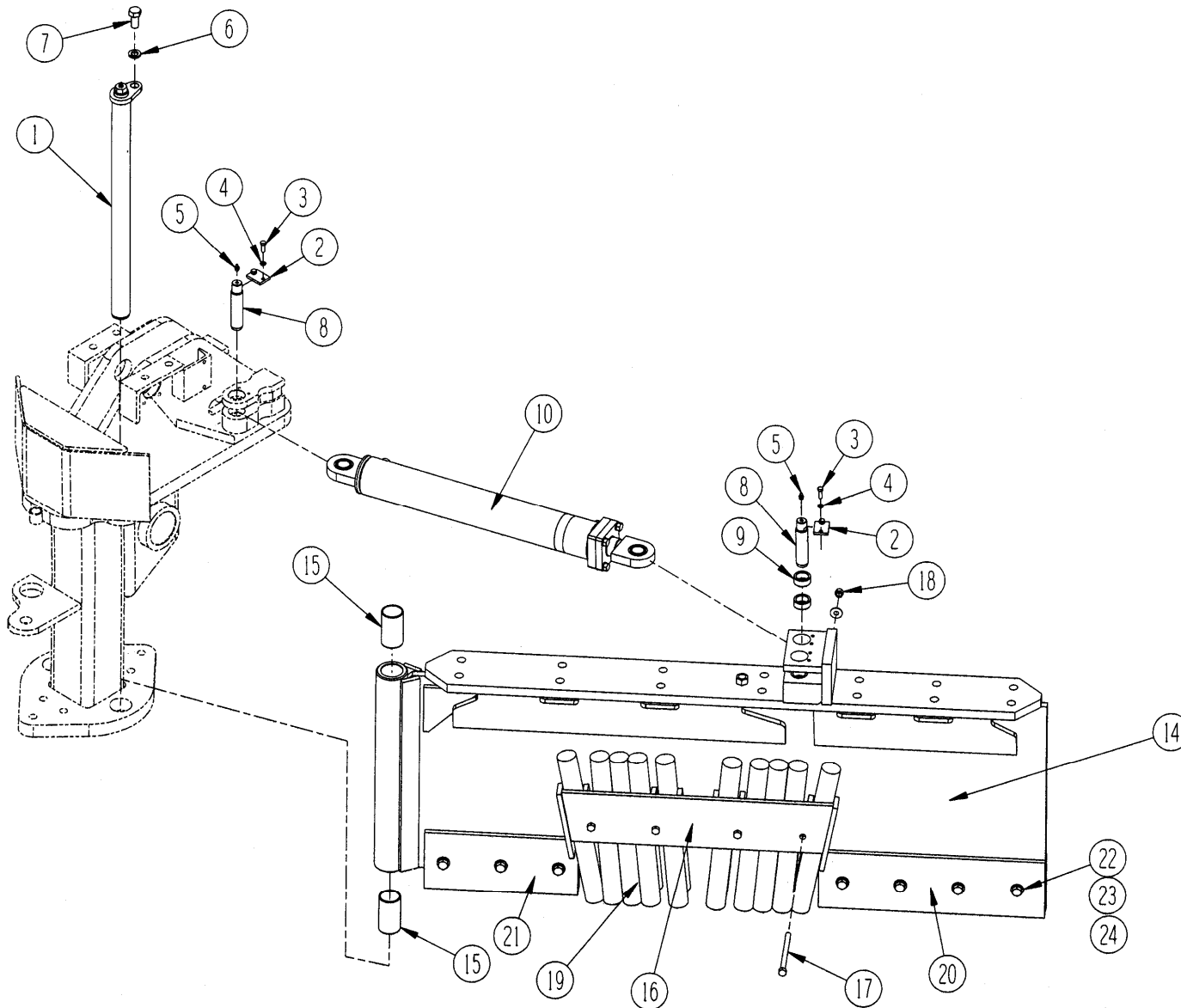


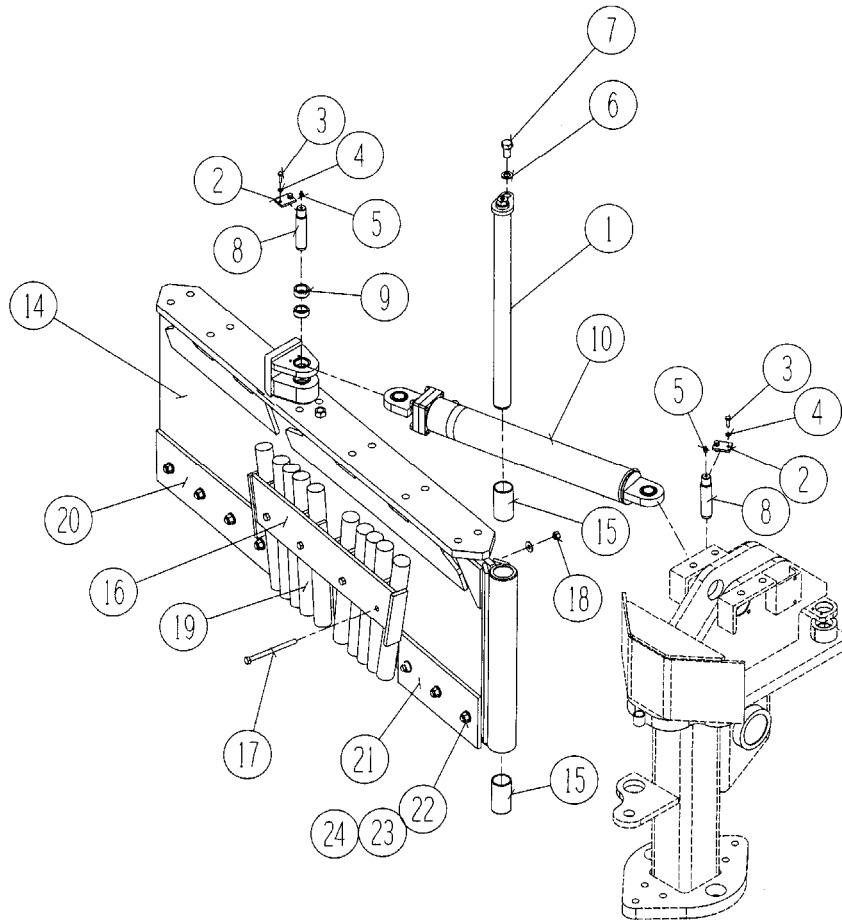
FIGURE 11-2-1A. FRONT PLOW Left Ballast Plow S/N 800301 and Above

ITEM NO.	PART NO.	DESCRIPTION	UNITS PER MACHINE
1	A-40548	Plow Hinge Rod.....	1
2	A-5200-61	Keeper Plate.....	2
3	0195	Capscrew 5/16 x 1	2
4	2761	5/16" Lockwasher	2
5	3004	Fitting, Grease.....	3
6	2768	Washer	1
7	0875	Bolt	1
8	810491	Pin, Cylinder Pivot	2
9	860535	Bushing, Cylinder Pivot	8
10	7500-120	Cylinder	1
--	SK-7500-98	. . Seal Kit.....	1
11	3895	Clamp, Support.....	4
12	0367	Bolt, Hex 3/8 x 3-3/4	1
13	2735	Washer, 3/8"	1
14	810223	Plow Blade	1
15	A-25077	Bushing	2
16	860310	Element Clamp	2
17	0615	Bolt, 1/2 x 6	4
18	2664	Nut, Stover	4
19A	B-40792	Plow Element (Derby).....	20
19B	B-40791	Plow Element (U-Nova)	20
19C	B-27738	Plow Element (Polyco)	20
20A	A-40323	Blade, 4-Hole (Standard).....	2
20B	840166	Blade, 4-Hole (BTI/Nordco) 1/2"	2
20C	840167	Blade, 4-Hole (BTI/Nordco) 3/4"	2
21A	A-25095	Blade, 3-Hole (Standard).....	2
21B	840164	Blade, 3-Hole (BTI/Nordco) 1/2"	2
21C	840165	Blade, 3-Hole (BTI/Nordco) 3/4"	2
22	0797	Bolt, Hex 5/8 x 3	7

ITEM NO.	PART NO.	DESCRIPTION	UNITS PER MACHINE
23	2668	Nut, Stover 5/8	7
24	2755-2	Washer, 5/8.....	14

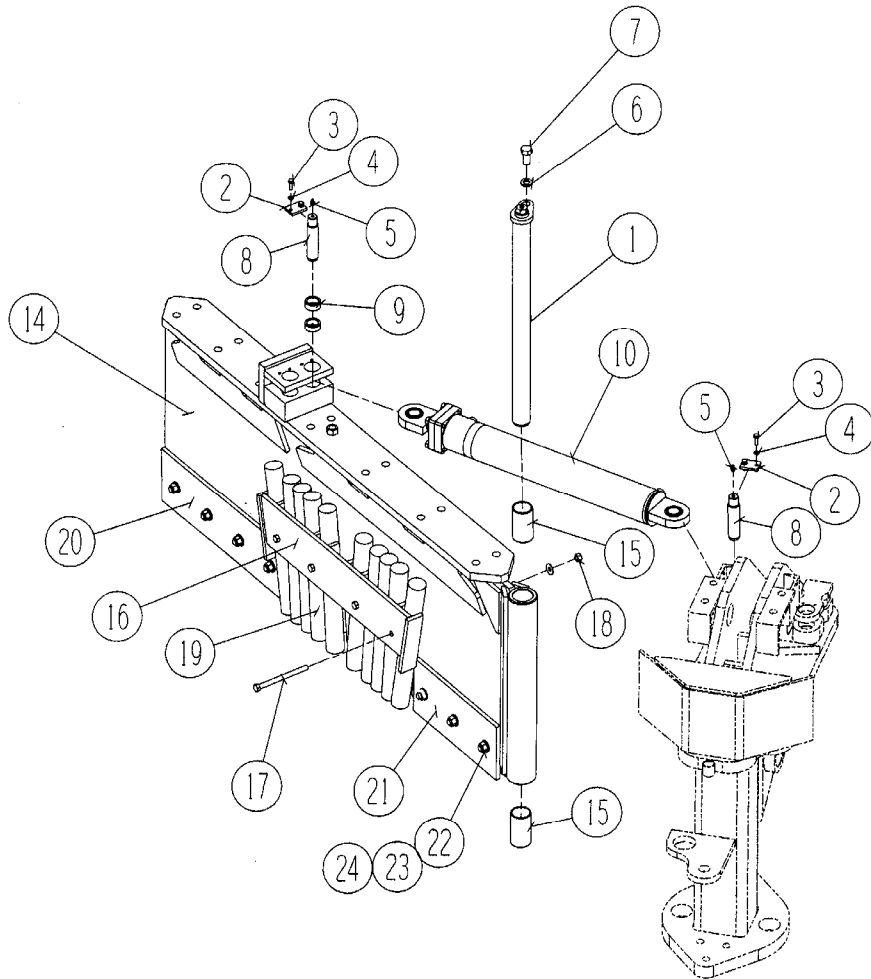
For Sliding Door Option, See Figure 11-2-3

FIGURE 11-2-2. FRONT PLOW Right Ballast Plow S/N 800300 Only



ITEM NO.	PART NO.	DESCRIPTION	UNITS PER MACHINE
1	A-40548	Plow Hinge Rod.....	1
2	A-5200-61	Keeper Plate.....	2
3	2774531	Capscrew 5/16 x 1.....	4
4	2761	5/16" Lockwasher.....	4
5	3004	Fitting, Grease.....	3
6	2768	Washer.....	1
7	0875	Bolt.....	1
8	810491	Pin, Cylinder Pivot.....	2
9	860535	Bushing, Cylinder Pivot.....	8
10	7500-120	Cylinder.....	1
--	SK-7500-98	.. Seal Kit.....	1
11	3895	Clamp, Support.....	4
12	0335	Bolt, Hex 3/8 x 1-3/4.....	1
13	2735	Washer, 3/8".....	1
14	700294	Plow Blade.....	1
15	A-25077	Bushing.....	2
16	860310	Element Clamp.....	2
17	0615	Bolt, 1/2 x 6.....	4
18	3042025	Nut, Stover.....	4
19A	B-40792	Plow Element (Derby).....	20
19B	B-40791	Plow Element (U-Nova).....	20
19C	B-27738	Plow Element (Polyco).....	20
20A	A-40323	Blade, 4-Hole (Standard).....	2
20B	840166	Blade, 4-Hole (BTI/Nordco) 1/2".....	2
20C	840167	Blade, 4-Hole (BTI/Nordco) 3/4".....	2
21A	A-25095	Blade, 3-Hole (Standard).....	2
21B	840164	Blade, 3-Hole (BTI/Nordco) 1/2".....	2
21C	840165	Blade, 3-Hole (BTI/Nordco) 3/4".....	2
22	0805	Bolt, Hex 5/8 x 3-1/2.....	7
23	2668	Nut, Stover 5/8.....	7
24	2755-2	Washer, 5/8.....	14

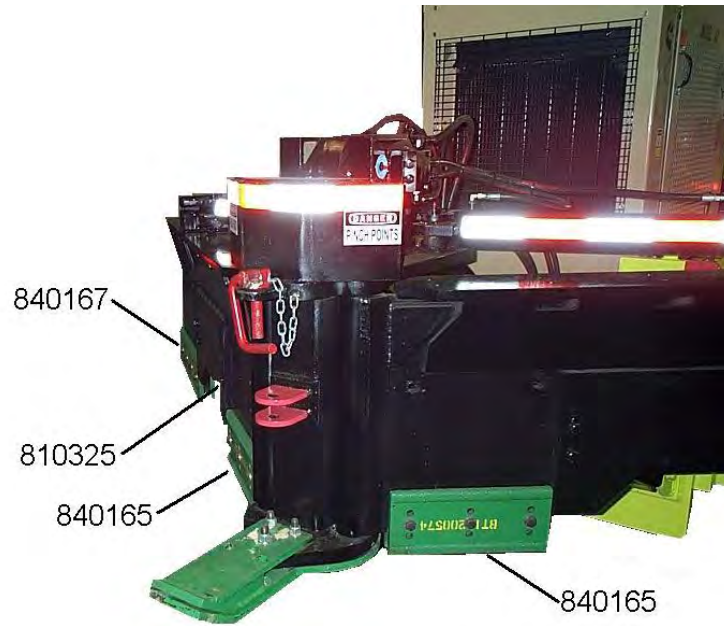
FIGURE 11-2-2A. FRONT PLOW Right Ballast Plow S/N 800301 and Above



ITEM NO.	PART NO.	DESCRIPTION	UNITS PER MACHINE
1	A-40548	Plow Hinge Rod.....	1
2	A-5200-61	Keeper Plate.....	2
3	0195	Capscrew 5/16 x 1.....	2
4	2761	5/16" Lockwasher.....	2
5	3004	Fitting, Grease.....	3
6	2768	Washer.....	1
7	0875	Bolt.....	1
8	810491	Pin, Cylinder Pivot.....	2
9	860535	Bushing, Cylinder Pivot.....	8
10	7500-120	Cylinder.....	1
--	SK-7500-98	.. Seal Kit.....	1
11	3895	Clamp, Support.....	4
12	0367	Bolt, Hex 3/8 x 3-3/4.....	1
13	2735	Washer, 3/8".....	1
14	810223	Plow Blade.....	1
15	A-25077	Bushing.....	2
16	860310	Element Clamp.....	2
17	0615	Bolt, 1/2 x 6.....	4
18	2664	Nut, Stover.....	4
19A	B-40792	Plow Element (Derby).....	20
19B	B-40791	Plow Element (U-Nova).....	20
19C	B-27738	Plow Element (Polyco).....	20
20A	A-40323	Blade, 4-Hole (Standard).....	2
20B	840166	Blade, 4-Hole (BTI/Nordco) 1/2".....	2
20C	840167	Blade, 4-Hole (BTI/Nordco) 3/4".....	2
21A	A-25095	Blade, 3-Hole (Standard).....	2
21B	840164	Blade, 3-Hole (BTI/Nordco) 1/2".....	2
21C	840165	Blade, 3-Hole (BTI/Nordco) 3/4".....	2
22	0797	Bolt, Hex 5/8 x 3.....	7
23	2668	Nut, Stover 5/8.....	7
24	2755-2	Washer, 5/8.....	14

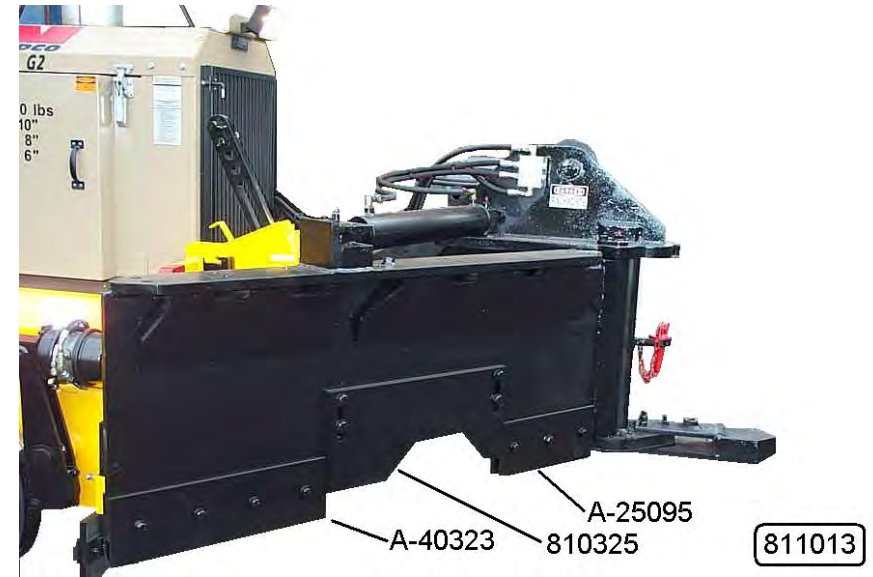
For Sliding Door Option, See Figure 11-2-3

**FIGURE 11-2-3. FRONT PLOW
Sliding Door Options
S/N 800300 and Above**



810245

Sliding Door with BTI Blades



Sliding Door with Hard-Ox Blades

FIGURE 11-3. FRONT PLOW
Front Plow Carrier
S/N 800300 and Above

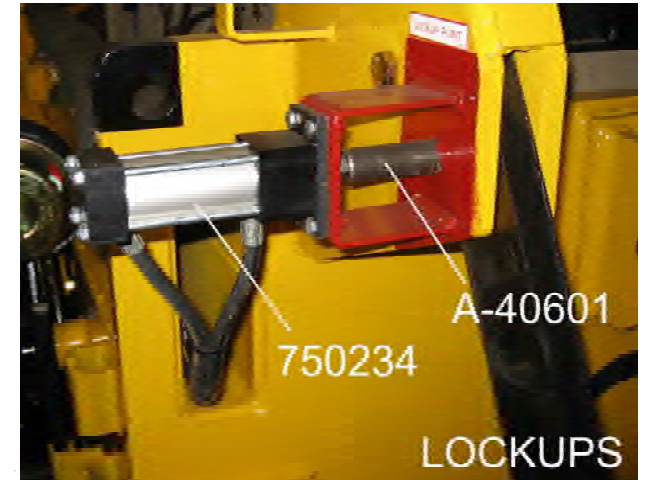
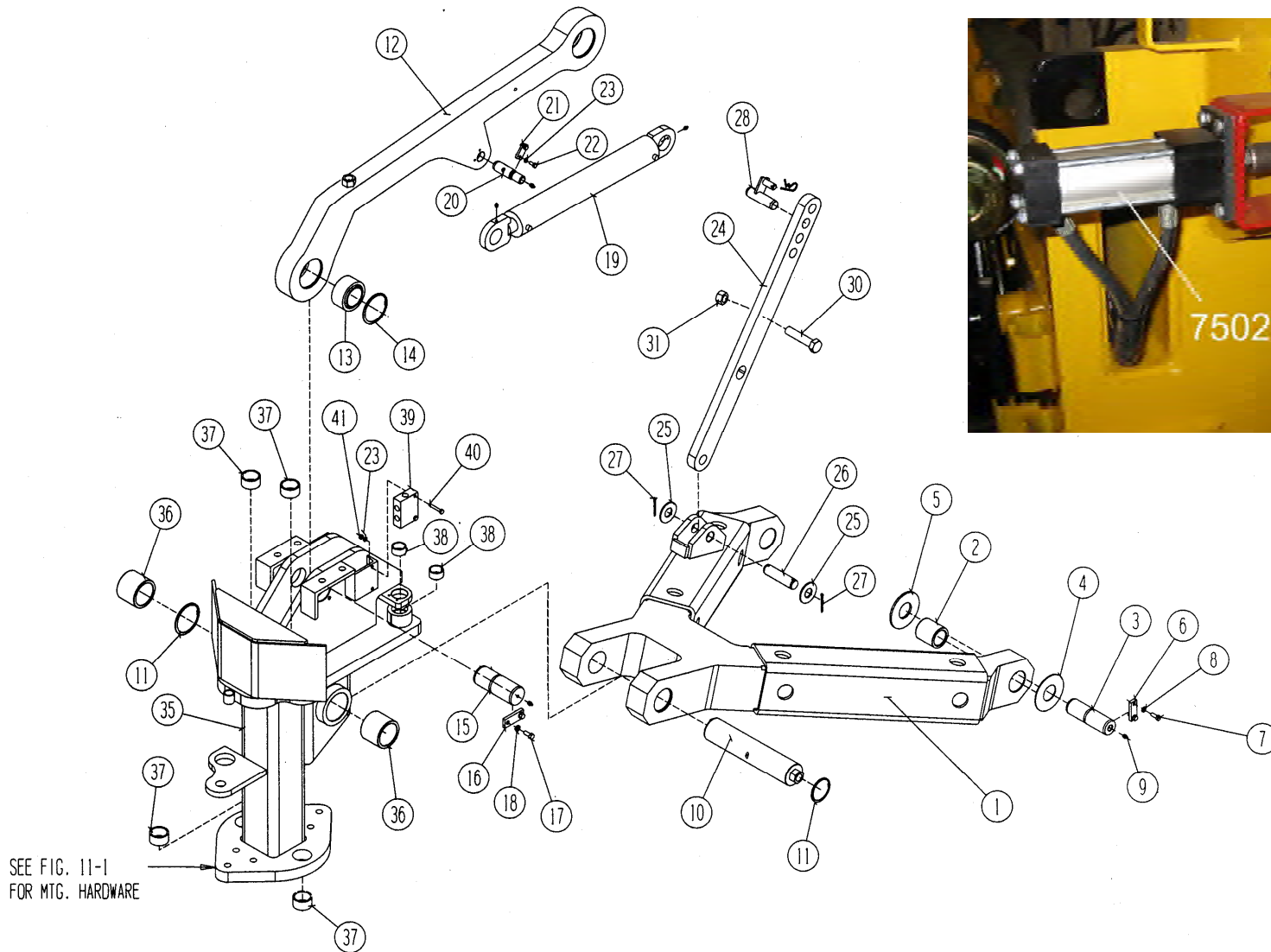


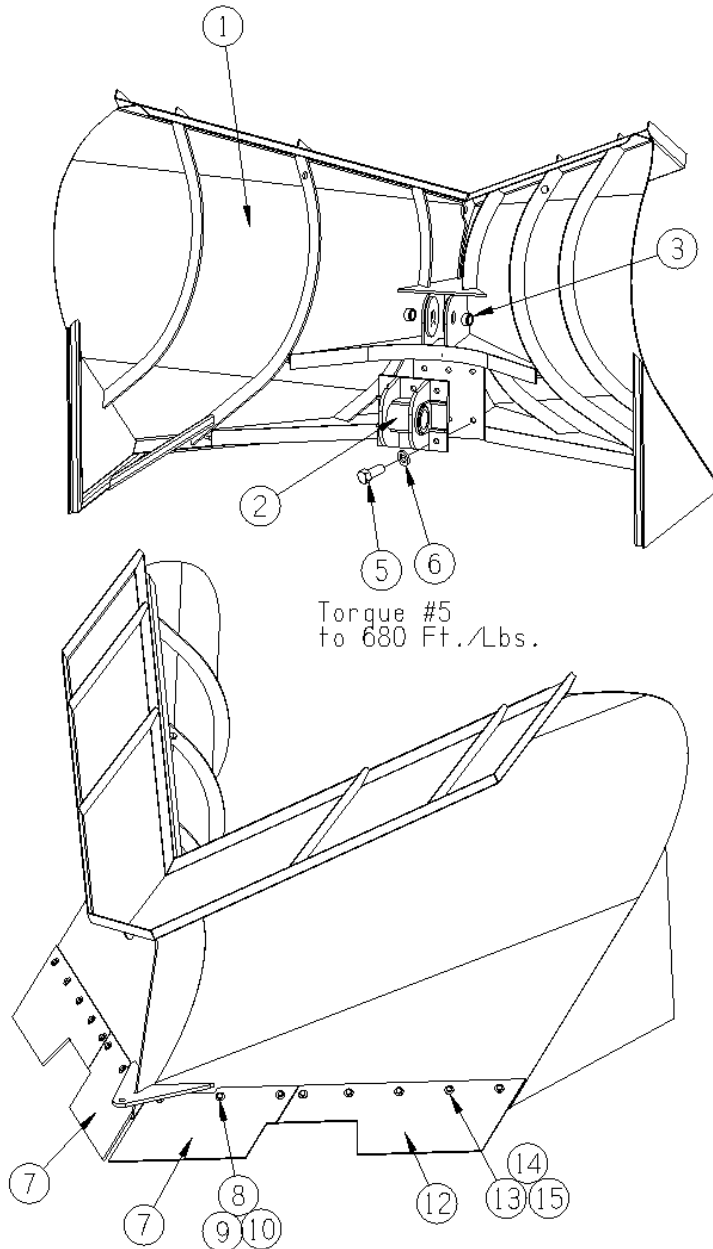
FIGURE 11-3. FRONT PLOW Front Plow Carrier S/N 800300 and Above

ITEM NO.	PART NO.	DESCRIPTION	UNITS PER MACHINE
1	860574	Lift Arm	1
2	A-6500-7	Bushing.....	2
3	B-40588	Lower Pivot Pin.....	2
4	A-40595	Washer, Thin	2
5	A-40594	Washer, Thick.....	2
6	A-5200-31	Keeper Plate.....	2
7	2774781	Capscrew HH	4
8	3064470	Lockwasher	4
9	3801052	Grease Fitting	10
10	B-40579	Pivot Pin	1
11	7667	Internal Retaining Ring	2
12	700289	Link Arm	1
13	6521	Spherical Self-Aligning Bearing	2
14	7666	Internal Retaining Ring	2
15	B-40587	Link Pin.....	2
16	A-5200-41	Keeper Plate.....	2
17	0439	Capscrew HH	4
18	3064473	Lockwasher	4
19	7500-227	Cylinder, Front Plow Lift	1
--	SK-7500-227	.. Seal Kit	1
20	B-4705-5	Pin	2
21	A-5200-21	Keeper Plate.....	2
22	2774521	Capscrew HH 5/16-18 X 3/4.....	4
23	3064467	Lockwasher	8
24	700398	Lock Up Bar.....	1
25	2717	Washer	2
26	A-5006-21	Cotter Type Headless Pin.....	1
27	2819	Cotter Pin.....	2
28	B-40609	Pin, Pivot	1
29*	2871	Pin, Hitch	1
30	0915	Bolt, Hex	1
31	3043028	¾-10 Stover Nut	1
32*	A-40606	Shim, Thick (Lockout Bar)	3
33*	A-40607	Shim, Thin (Lockout Bar).....	2

ITEM NO.	PART NO.	DESCRIPTION	UNITS PER MACHINE
34*	A-40608	Pipe, Lock Strut.....	1
35	860551	Front Mount.....	1
36	A-40596	Steel Bushing 3" ID	2
37	A-27763	Bushing, Hardened 2" ID.....	4
38	860535	Bushing, Hardened 1-1/2" iD.....	4
39	F-611	Valve, Check.....	2
40	0211	Bolt, Hex 5/16 x 2.....	4
41	3001018	Nut, Hex	4

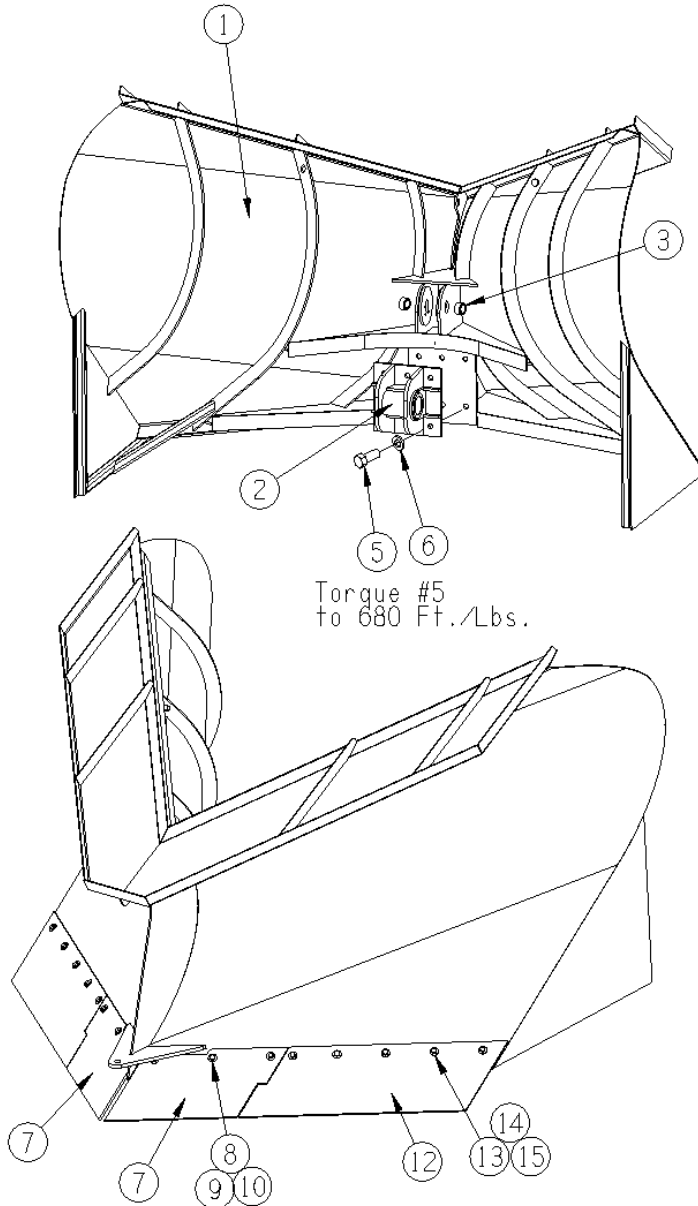
ⓘ Illustration to be updated to reflect this mount. Part Number is correct.

FIGURE 11-4-1. FRONT PLOW High Speed V-Plow (Std) w/Blade Cutouts S/N 800300 and Above



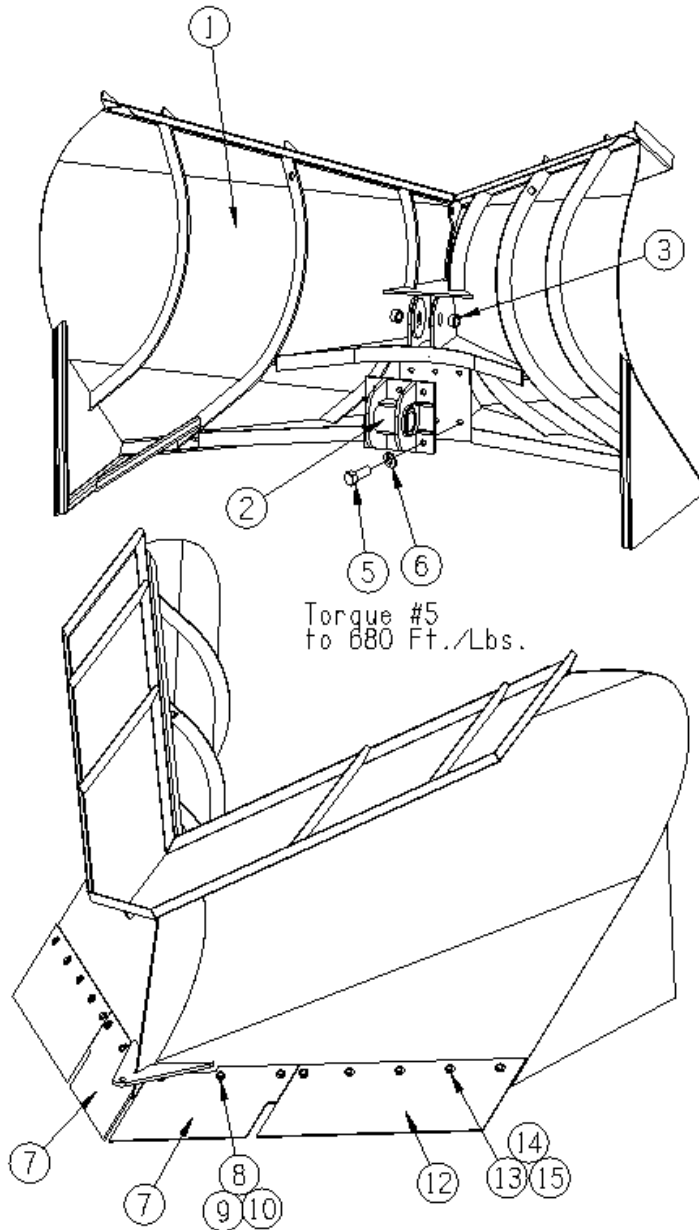
ITEM NO.	PART NO.	DESCRIPTION	UNITS PER MACHINE
1	802364	High Speed V-Plow (120").....	1
2	802365	Mounting Pivot.....	1
3	A-40596	Steel Bushing	2
4	802371	Locking Plate.....	3
5	1103	1" x 3-1/2" Hex Bolt (Grade 8).....	6
6	2742	1" SAE Flat Washer.....	6
--	802369	Inside Flanging Assembly	1
7	802366	. Inside Flanging Plate.....	2
8	0785	. 5/8" x 2-1/4" Hex Bolt (Grade 5).....	6
9	2668	. 5/8" Stover Nut	6
10	2739	. 5/8" Washer.....	12
--	802370	Outside Flanging Assembly.....	1
12	802367	. Outside Flanging Plate	2
13	0785	. 5/8" x 2-1/4" Hex Bolt (Grade 5).....	10
14	2668	. 5/8" Stover Nut	10
15	2739	. 5/8" Washer.....	20
16*	840040	Front Light Bracket.....	1

FIGURE 11-4-2. FRONT PLOW High Speed V-Plow w/Straight Outside Flanging S/N 800300 and Above



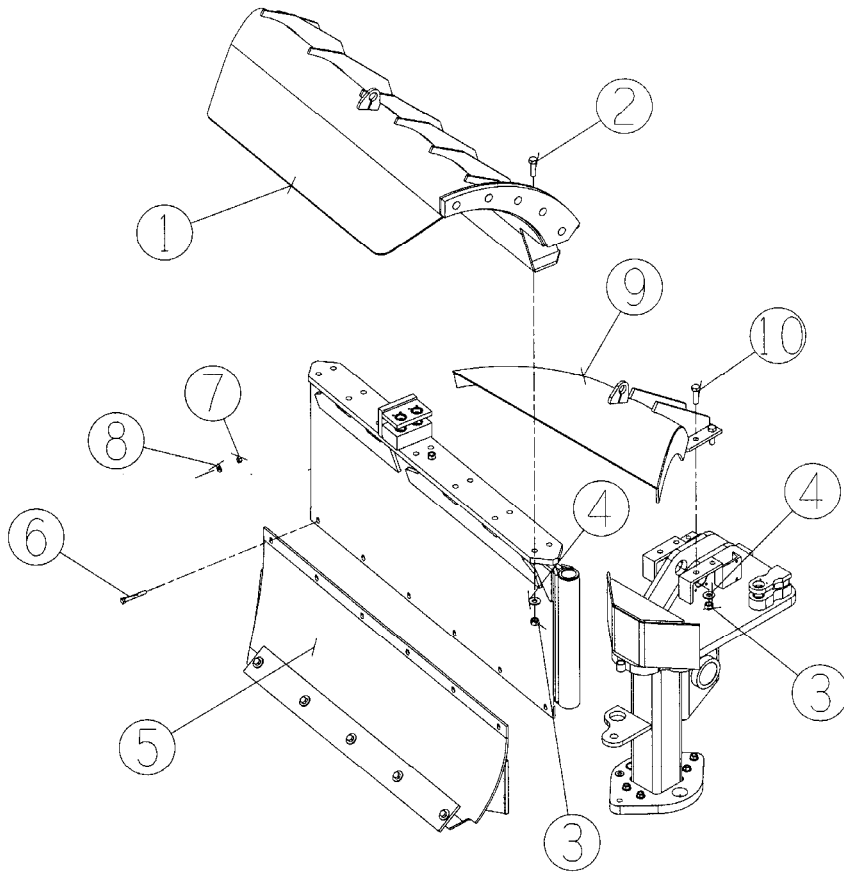
ITEM NO.	PART NO.	DESCRIPTION	UNITS PER MACHINE
1	802364	High Speed V-Plow (120").....	1
2	802365	Mounting Pivot.....	1
3	A-40596	Steel Bushing	2
4	802371	Locking Plate.....	3
5	1103	1" x 3-1/2" Hex Bolt (Grade 8).....	6
6	2742	1" SAE Flat Washer.....	6
--	802369	Inside Flanging Assembly	1
7	802366	. Inside Flanging Plate.....	2
8	0785	. 5/8" x 2-1/4" Hex Bolt (Grade 5).....	6
9	2668	. 5/8" Stover Nut	6
10	2739	. 5/8" Washer.....	12
--	460247	Outside Flanging Assembly.....	1
12	700250	. Outside Flanging Plate	2
13	0785	. 5/8" x 2-1/4" Hex Bolt (Grade 5).....	10
14	2668	. 5/8" Stover Nut	10
15	2739	. 5/8" Washer.....	20
16*	840040	Front Light Bracket.....	1

FIGURE 11-4-3. FRONT PLOW High Speed V-Plow w/Protective Outside Flanging S/N 800300 and Above



ITEM NO.	PART NO.	DESCRIPTION	UNITS PER MACHINE
1	802364	High Speed V-Plow (120").....	1
2	802365	Mounting Pivot.....	1
3	A-40596	Steel Bushing	2
4	802371	Locking Plate.....	3
5	1103	1" x 3-1/2" Hex Bolt (Grade 8).....	6
6	2742	1" SAE Flat Washer.....	6
--	802369	Inside Flanging Assembly	1
7	802366	. Inside Flanging Plate.....	2
8	0785	. 5/8" x 2-1/4" Hex Bolt (Grade 5).....	6
9	2668	. 5/8" Stover Nut	6
10	2739	. 5/8" Washer.....	12
--	460284	Outside Flanging Assembly.....	1
12	700279	. Outside Flanging Plate	2
13	0785	. 5/8" x 2-1/4" Hex Bolt (Grade 5).....	10
14	2668	. 5/8" Stover Nut	10
15	2739	. 5/8" Washer.....	20
16*	840040	Front Light Bracket.....	1

FIGURE 11-5-1. FRONT PLOW Snow Curls S/N 800300 and Above



ITEM NO.	PART NO.	DESCRIPTION	UNITS PER MACHINE
1A	802212	Upper Snow Curl, RH (Shown)	1
1B*	802211	Upper Snow Curl, LH	1
2	0893	Bolt, Hex 3/4-10 x 2-1/2"	32
3	3043028	Nut, Stover 3/4-10	32
4	2740	Washer	32
5A	802216	Lower Snow Curl, RH (Shown)	1
5B*	802215	Lower Snow Curl, LH	1
6	0793	Bolt, Hex 5/8 NC x 2-3/4 Grade 5.....	20
7	2668	Nut, Stover 5/8-11	20
8	2708	Washer, 5/8" Flat.....	40
9	802213	Center Cover	1
10	0885	Bolt, Hex 3/4 x 2 Grade 5	4

FIGURE 12-1. FIXED BALLAST WING
Ballast Wing Boom
S/N 800300 and Above

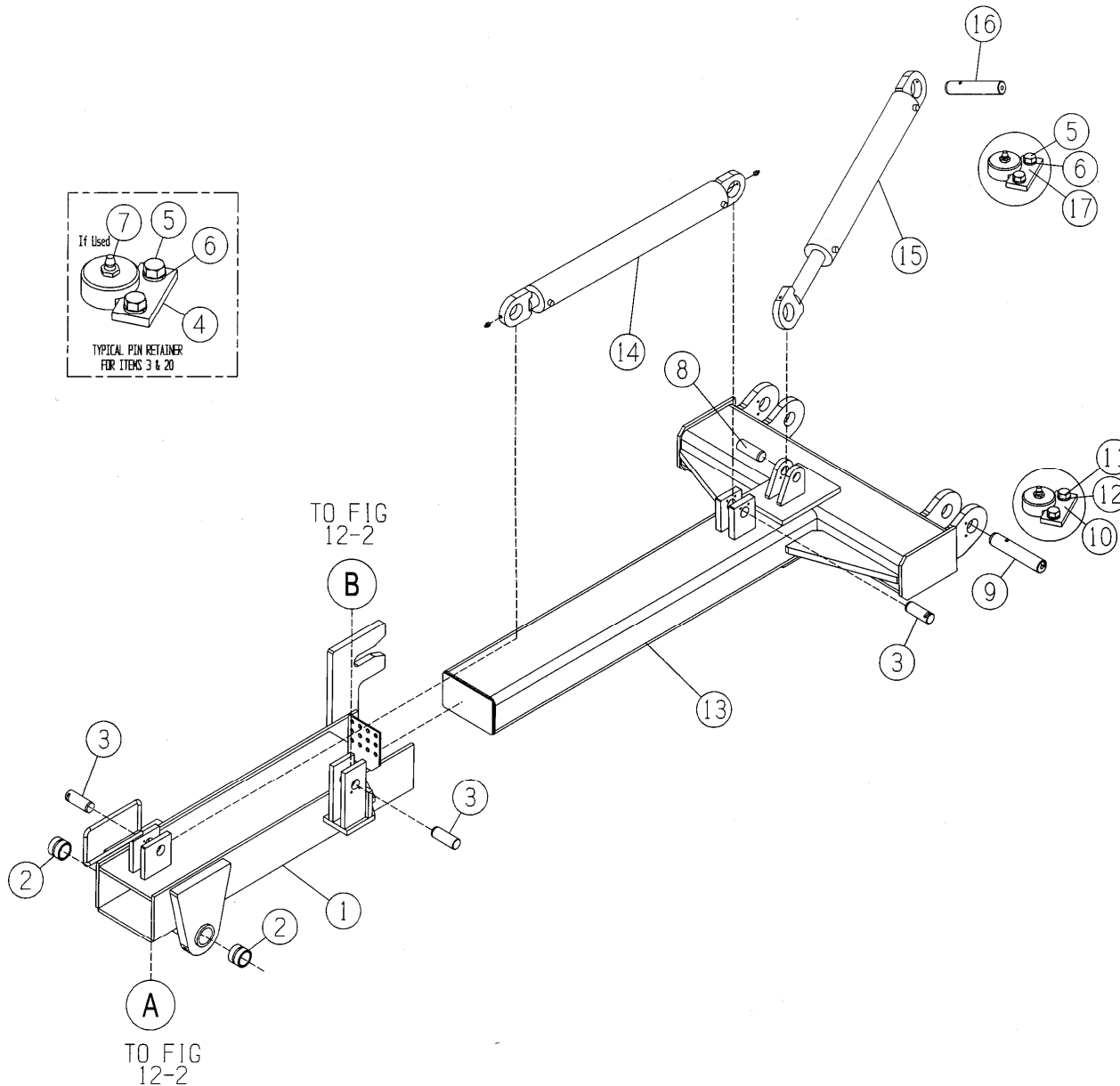
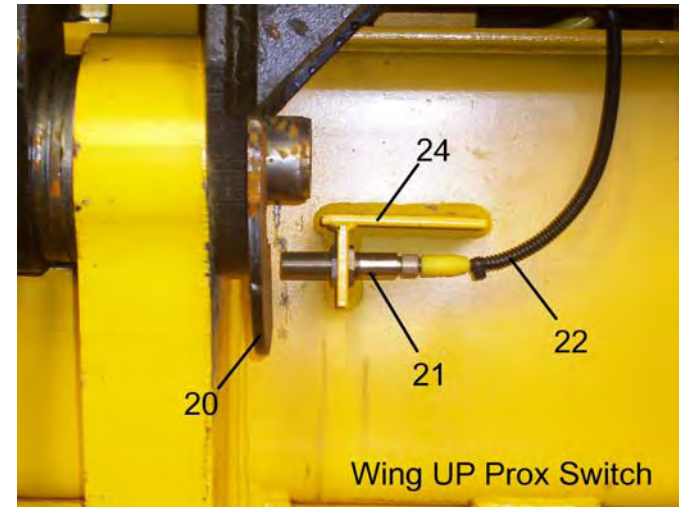


FIGURE 12-1. FIXED BALLAST WING Ballast Wing Boom S/N 800300 and Above

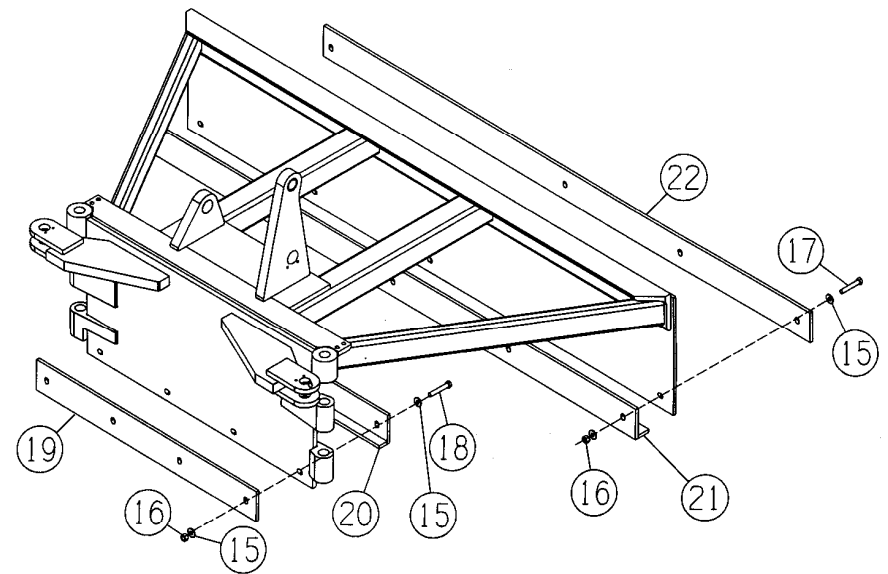
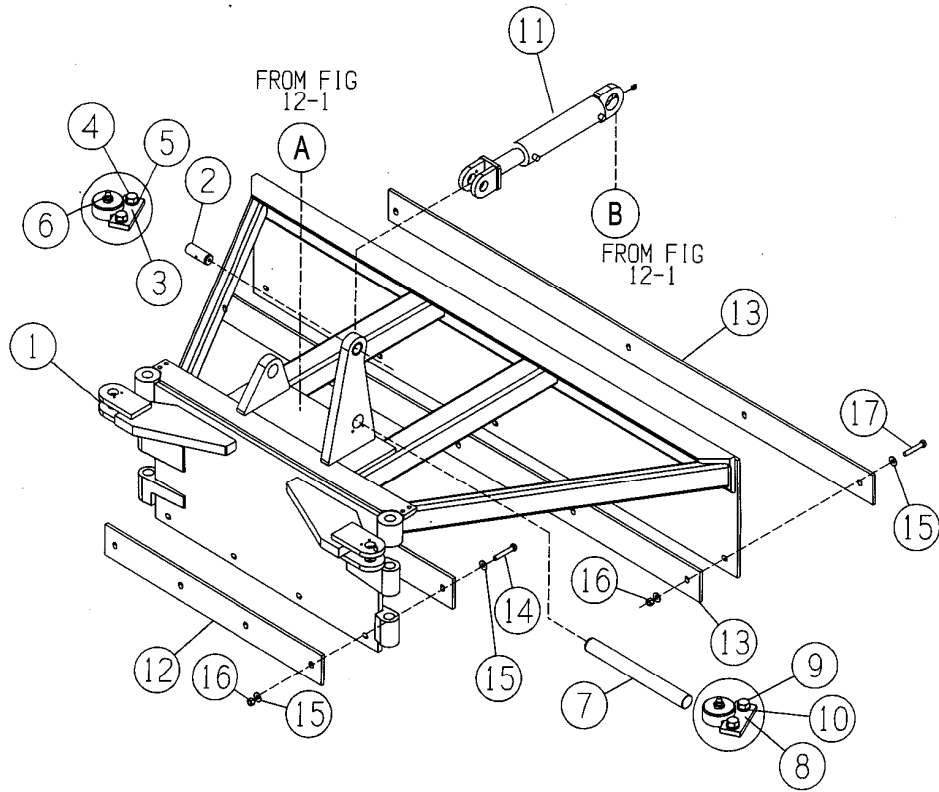
ITEM NO.	PART NO.	DESCRIPTION	UNITS PER ASSY
1A	700299	RH Outer Boom (Shown)	1
1B*	700308	LH Outer Boom	1
2	700302	.. Steel Bushing.....	2
3	810332	Pin, 1-1/2 x 4.13.....	3
4	810447	Keeper Plate	5
5	2774521	Hex Head Bolt, 5/16-18 x 3/4.....	10
6	3064467	Lockwasher, 5/16.....	10
7	3801052	Grease Fitting	10
8	A-25470	Wing Pivot Pin.....	2
9	700183	Cylinder Pin (Rod End)	1
10	A-5200-31	Keeper Plate	3
11	0323	Hex Head Bolt, 3/8-16 x 1	6
12	2762	Lockwasher, 3/8.....	6
13	700298	Inner Boom	1
14	750239	Boom Motion Cylinder (In/Out)	1
15	750229	Wing Lift Cylinder.....	1
16	700182	Cylinder Pin (Cap End)	1
17	A-5200-21	Keeper Plate	1



The following items are located on the frame next to the wings and control the Wing UP functions. When switching from ballast to snow wings, item 20A is replaced by 20B.

ITEM NO.	PART NO.	DESCRIPTION	UNITS PER ASSY
20A	700085	Flag, Prox Switch (Summer)	1
20B	802077	Flag, Prox Switch (Winter)	1
21	5127411	Switch, Prox.....	1
22	22311601-060	Cable, Microfast Prox Switch.....	1
24	802072	Prox Switch Mtg. Bracket.....	1

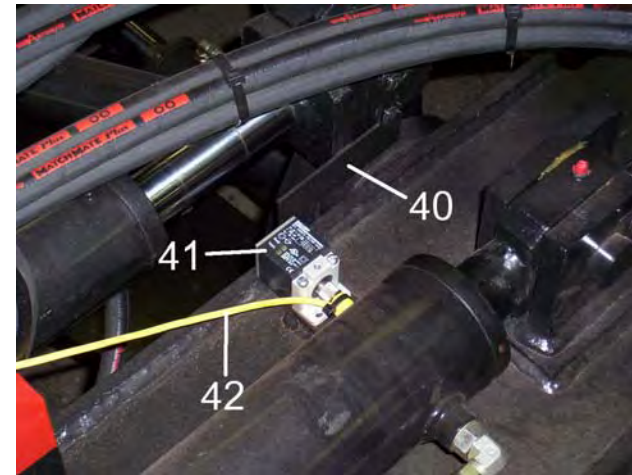
**FIGURE 12-2. FIXED BALLAST WING
Outer/Inner Door
S/N 800300 and Above**



BTI/NORDCO PARTNERSHIP PARTS

FIGURE 12-2. FIXED BALLAST WING Outer/Inner Door S/N 800300 and Above

ITEM NO.	PART NO.	DESCRIPTION	UNITS PER ASSY
1A	700301	RH Outer/Inner Door (Shown)	1
1B	700306	LH Outer/Inner Door	1
2	810692	Pivot Pin.....	1
3	810447	Keeper Plate	5
4	2774521	Hex Head Bolt, 5/16-18 x 3/4.....	10
5	3064467	Lockwasher, 5/16.....	10
6	3801052	Grease Fitting	10
7	700312	Wing Tilt Pin.....	1
8	A-5200-31	Keeper Plate	3
9	2774781	Hex Head Bolt, 3/8-16 x 1	6
10	3064470	Lockwasher, 3/8.....	6
11	750237	Ballast Wing Tilt Cylinder	1
12	700314	Outer Grader Blade (Hard-Ox).....	1
13	700315	Inner Grader Blade (Hard-Ox)	1
14	0793	Hex Head Bolt, 5/8-11 x 2-3/4.....	4
15	2755-2	Alloy Flat Washer, 5/8.....	18
16	2668	Nut, 5/8-11	9
17	0785	Hex Head Bolt, 5/8-11 x 2-1/4.....	5
18	0797	Hex Head Bolt, 5/8-11 x 3.....	4
19	700323	Outer Grader Blade Wear Bar (BTI)	1
20	700322	Outer Grader Blade L-Bar (BTI).....	1
21	700....	Inner Grader Blade L-Bar (BTI).....	1
22	700324	Inner Grader Blade Wear Bar (BTI)	1



The following items are located on the outer door assembly and control the Door Tilt functions. To switch out to snow wings, the prox cable should be removed from the junction box only (hoses and cables remain attached to outer door components)

ITEM NO.	PART NO.	DESCRIPTION	UNITS PER ASSY
40	802 076	Flag, Prox Switch	1
41	5127 415	Switch, Prox (Stubby)	1
42	22311601-184	Cable, Microfast Prox Switch	1

NOTE: Items 12-14 are replaced by 18-22 when BTI/Nordco Partnership parts are installed.

**FIGURE 12-3. FIXED BALLAST WING
Template Doors
Non-Articulating
S/N 800300 and Above**

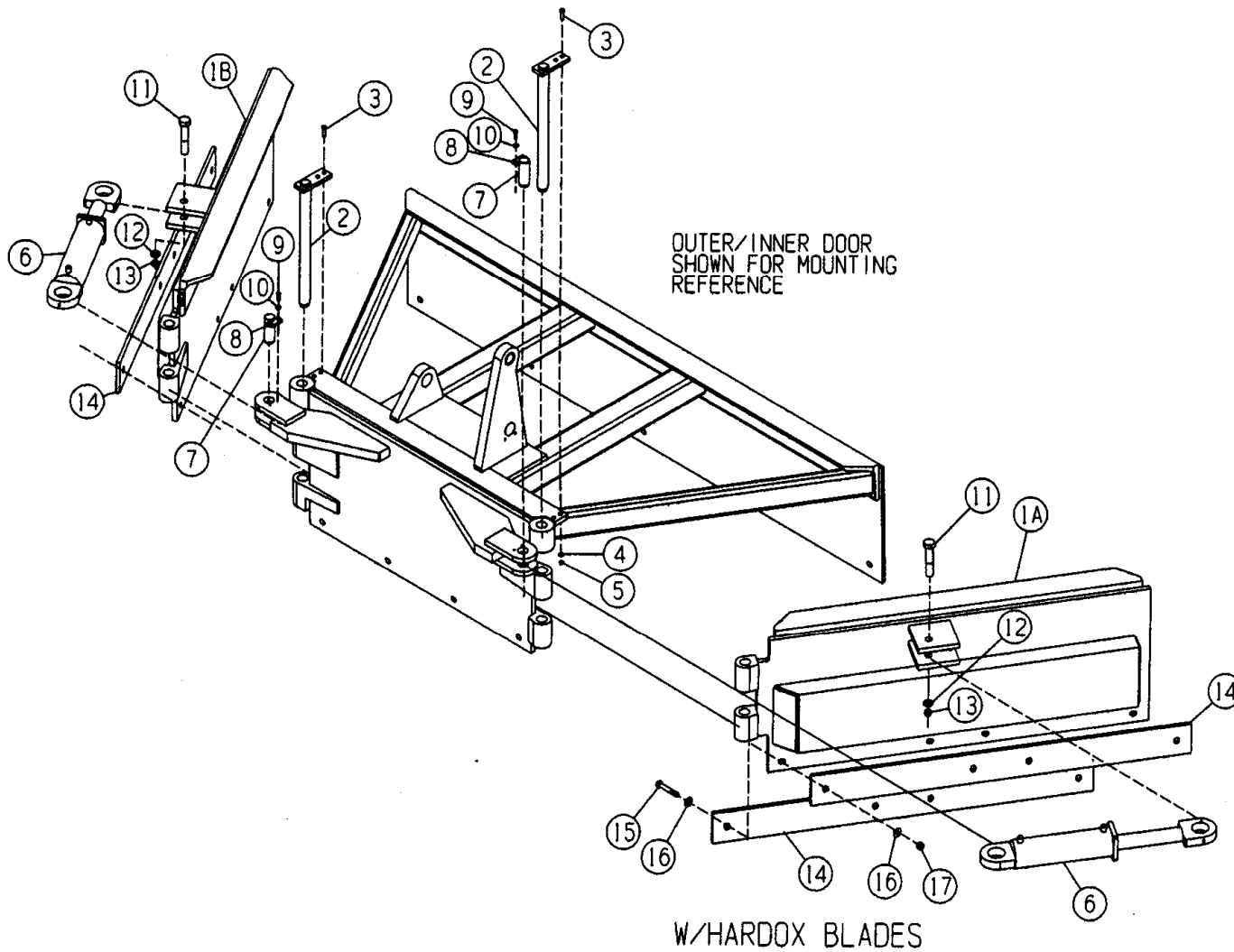




FIGURE 12-3. FIXED BALLAST WING Template Doors Non-Articulating S/N 800300 and Above

ITEM NO.	PART NO.	DESCRIPTION	UNITS PER SIDE
1A	700304	RHF/LHR Template Door.....	1
1B	700307	RHR/LHF Template Door.....	1
2	700310	Template Door Pivot Pin	1
3	0565	Hex Head Bolt, 1/2-13 x 2.....	2
4	3060476	Washer, 1/2.....	2
5	3042025	Hex Nut, 1/2-13.....	2
6	750238	Door Pivot Cylinder	1
7	810332	Cylinder Pin.....	1
8	810447	Keeper Plate	1
9	2774521	Hex Head Bolt, 5/16-18 x 3/4.....	2
10	3064467	Lockwasher, 5/16.....	2
11	1154	Hex Head Bolt, 1"-8 x 5" Grade 2	1
12	2771	Lockwasher, 1".....	1
13	2520	Hex Nut, 1"-8.....	1
14⓪	700316	Template Door Blade (Hardox)	2
15⓪	0793	Hex Head Bolt, 5/8-11 x 2-3/4.....	4
16	2755-2	Flat Washer, 5/8.....	8
17	2668	Hex Nut, 5/8-11	4
18	700320	Template Door L-bar Blade (BTI).....	1
19	700321	Template Door Wear Liner (BTI).....	1
20	0797	Hex Head Bolt, 5/8-11 x 3.....	4
21*	3801052	Grease Fitting	6

⓪ NOTE: Items 14 and 15 are replaced by Items 18-20 when using BTI/Nordco Partnership parts.

FIGURE 12-1. Ballast Wing Rotational Wings

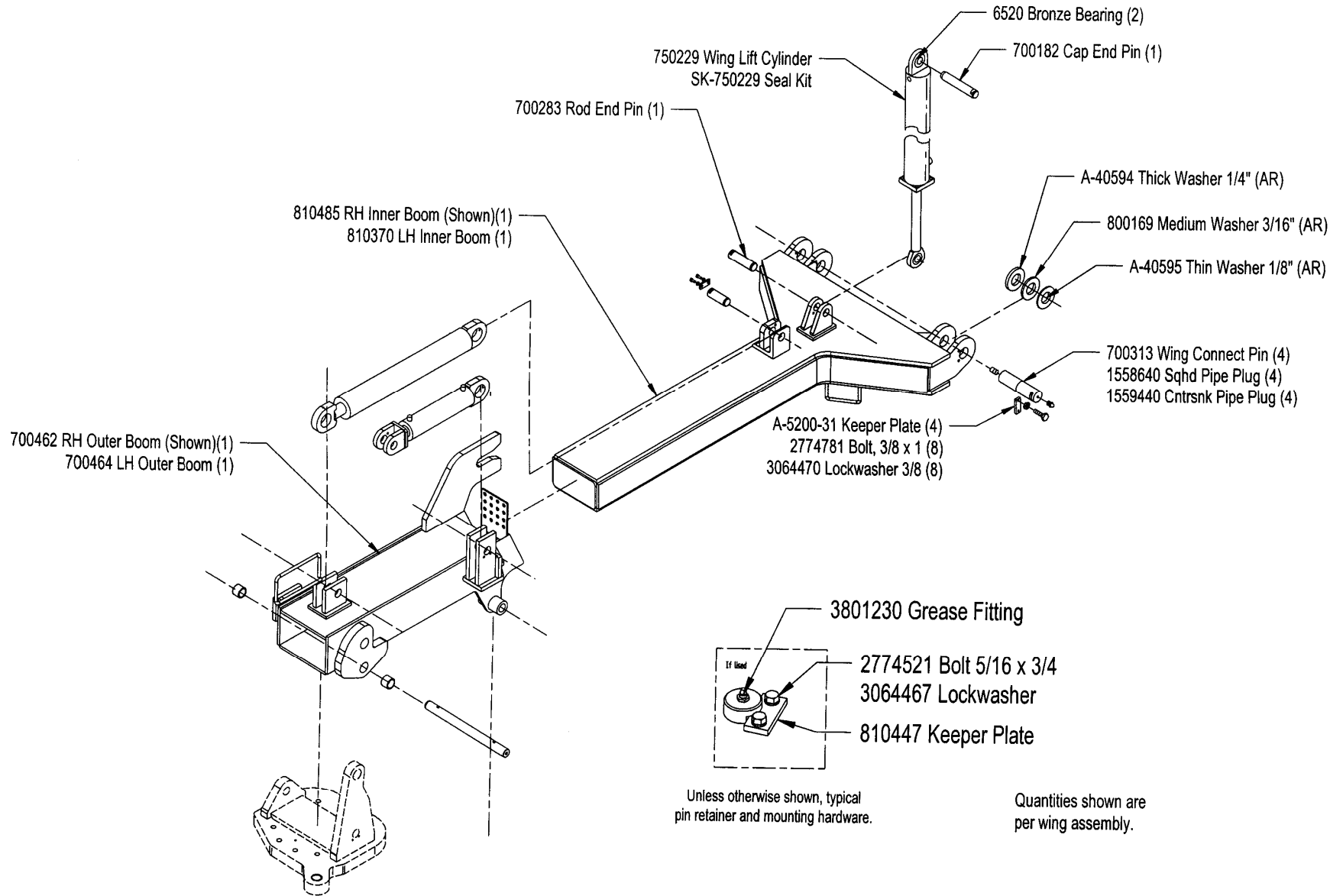
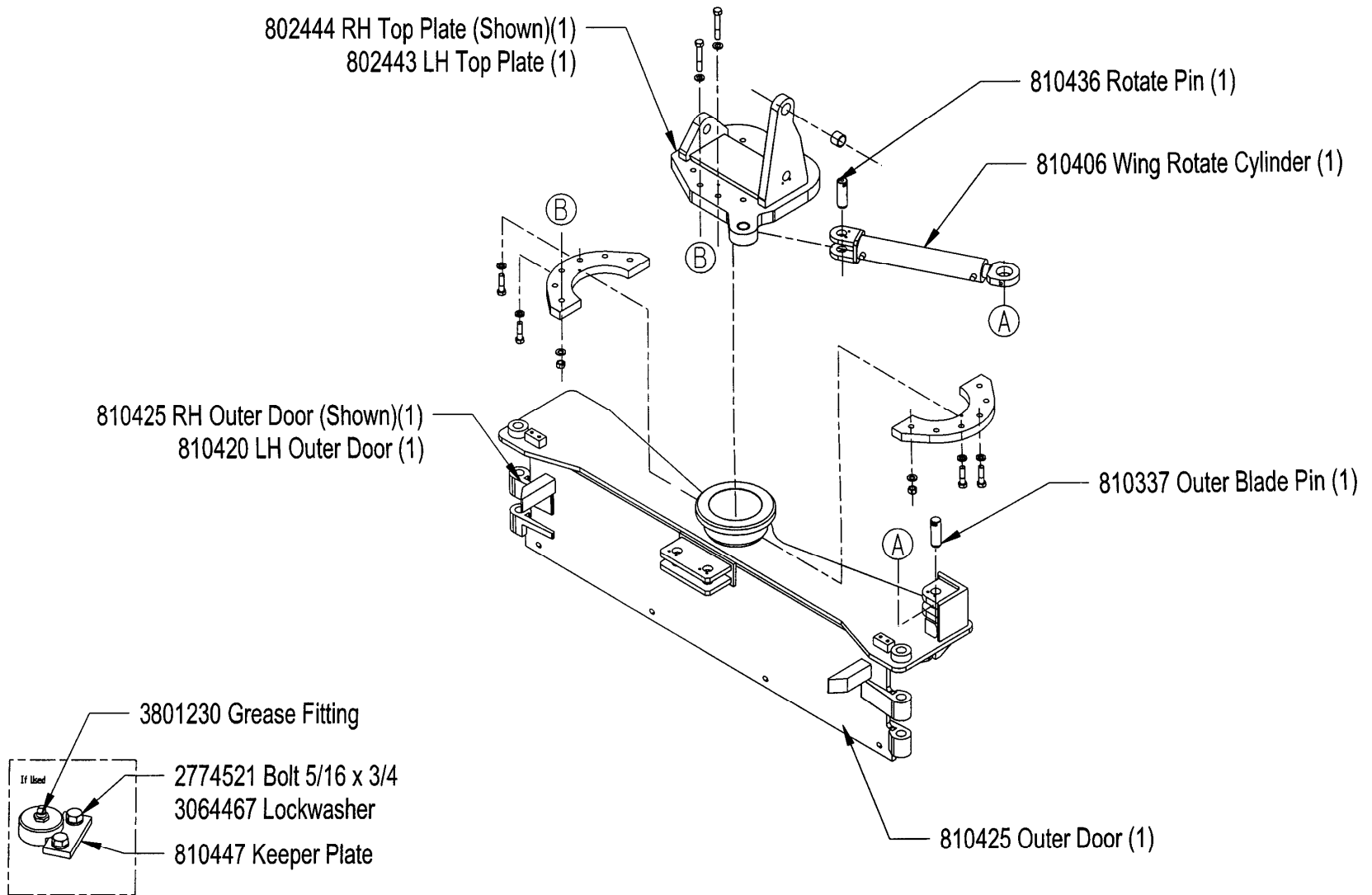


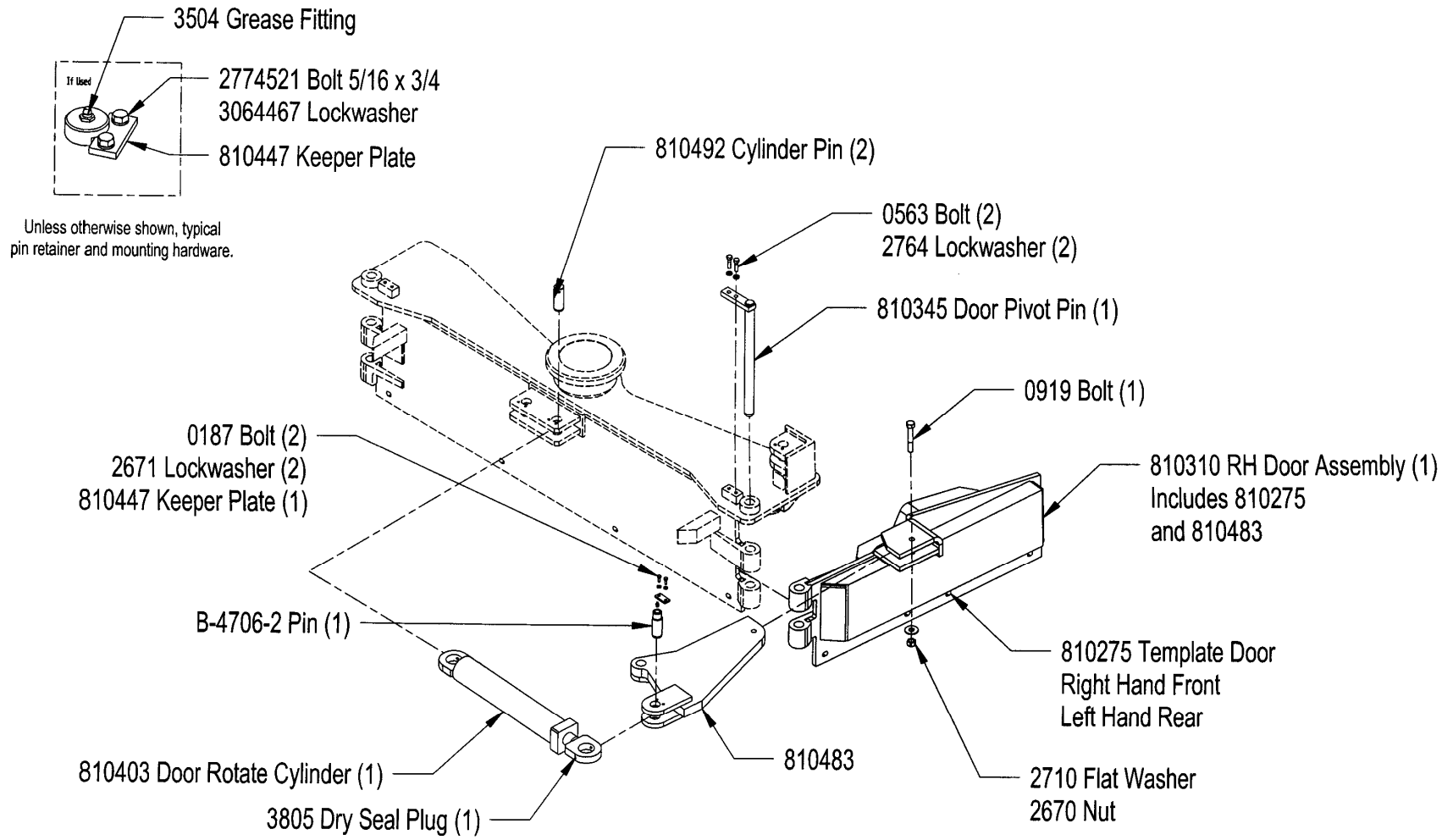
FIGURE 12-1. Ballast Wing Rotational Wings



Unless otherwise shown, typical pin retainer and mounting hardware.

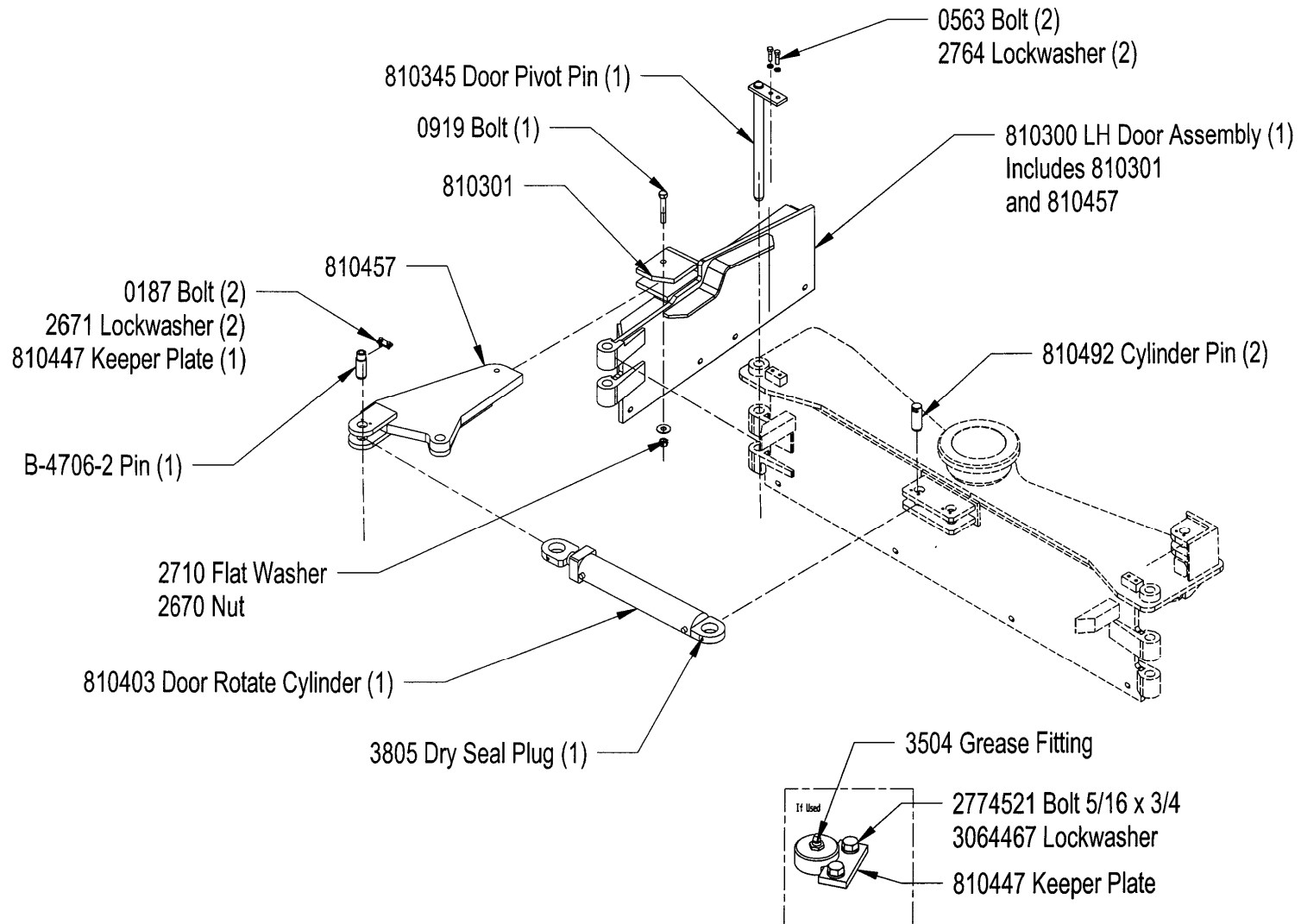
Quantities shown are per wing assembly.

FIGURE 12-1. Ballast Wing Rotational Wings



RIGHT FRONT TEMPLATE DOOR
LEFT REAR TEMPLATE DOOR

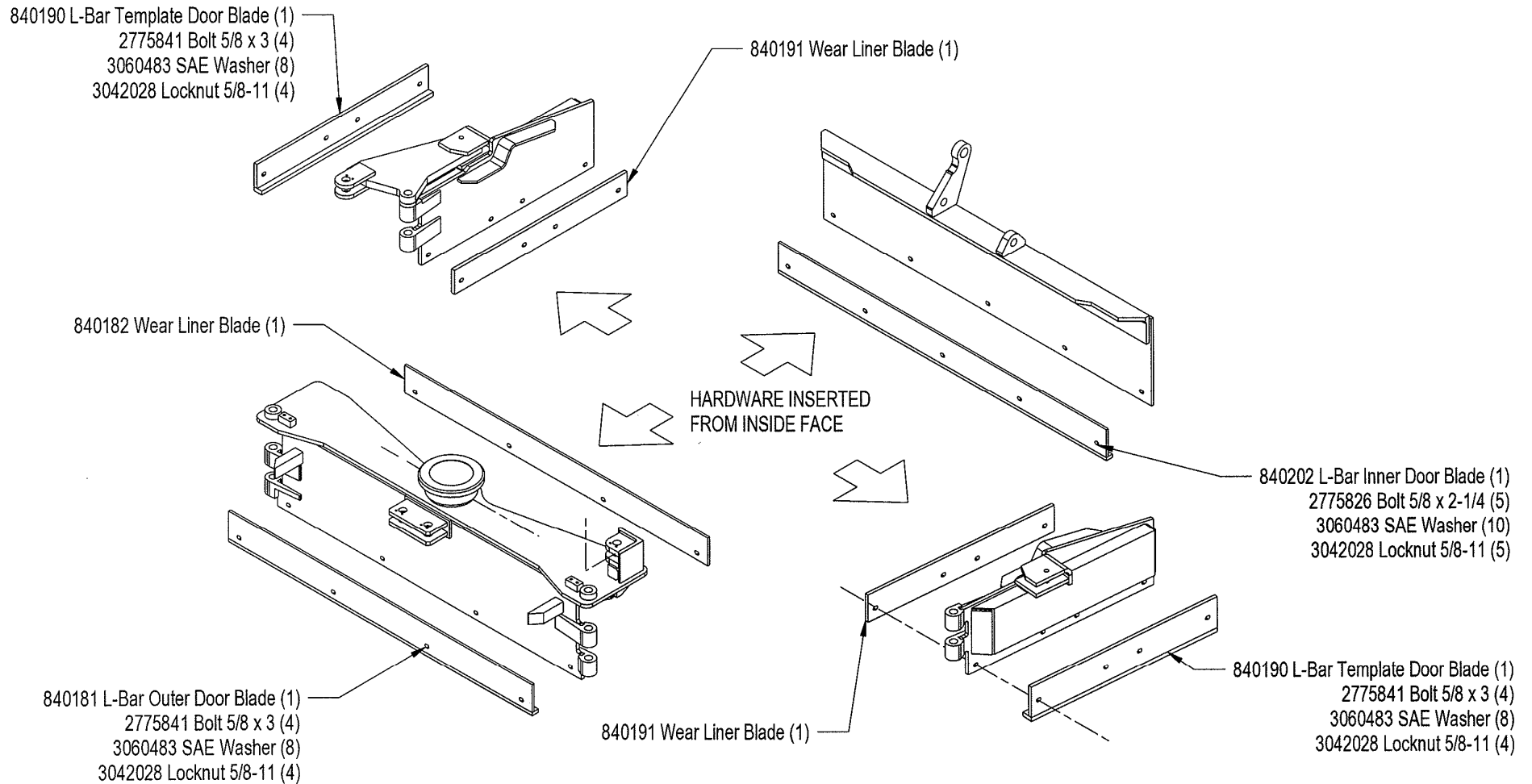
FIGURE 12-1. Ballast Wing Rotational Wings



Unless otherwise shown, typical pin retainer and mounting hardware.

RIGHT REAR TEMPLATE DOOR
LEFT FRONT TEMPLATE DOOR

**FIGURE 12-2. Ballast Wing
Rotational Wings
Grader Blades**



BTI GRADER BLADES

FIGURE 15-1A. BROOM BROOM CARRIER Direct Drive

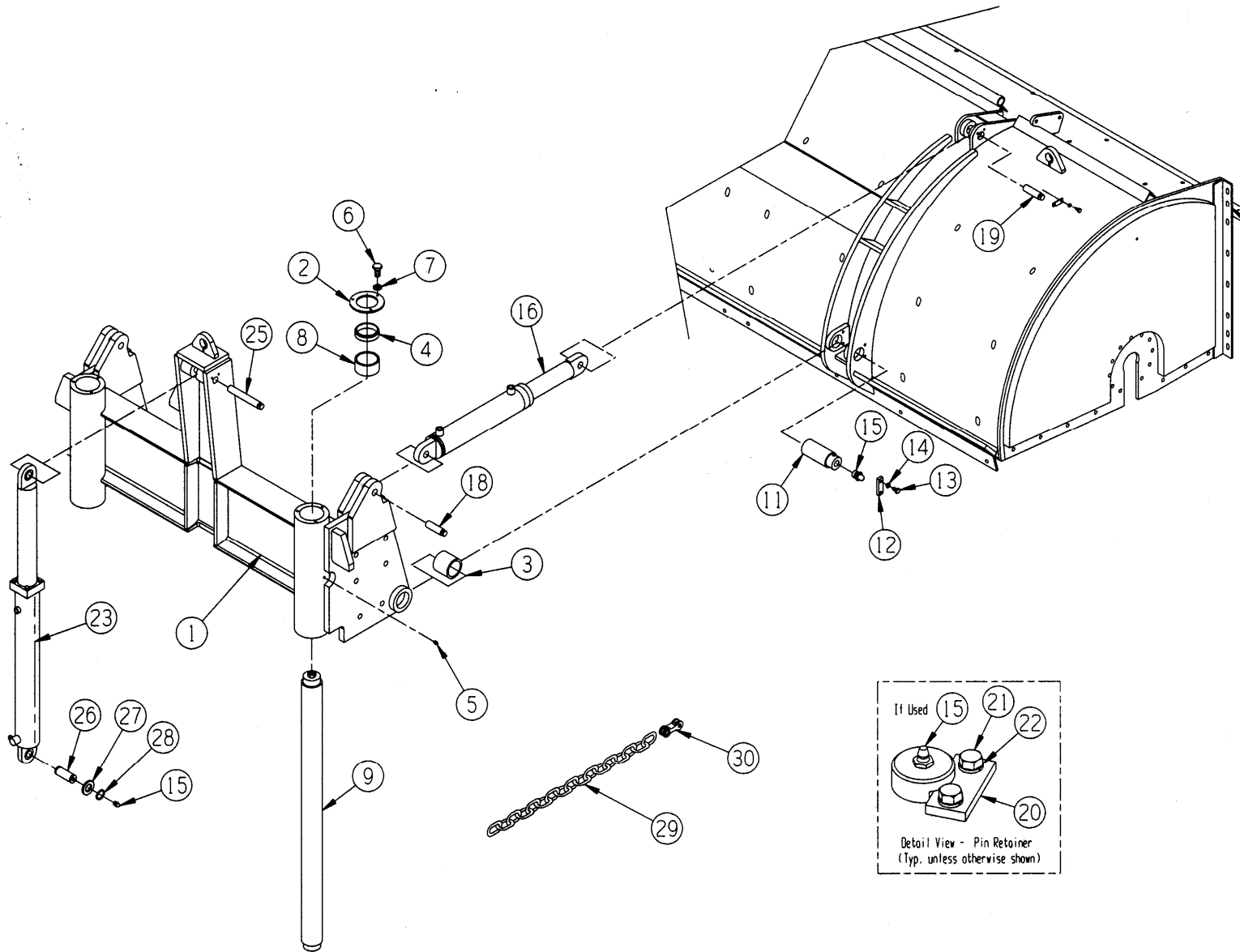




FIGURE 15-1A. BROOM BROOM CARRIER Direct Drive

ITEM NO.	PART NO.	DESCRIPTION	UNITS PER MACHINE
1	700027	. Broom Carrier	1
2	A-27938	. Retaining Ring	4
3	A-25473	. Bronze Bushing	2
4	3900-36	. Wiper Ring	4
5	3004	. Grease Fitting	2
6	0181	. Hex Head Bolt	6
7	2761	. Lock Washer	6
8	A-25083	Bronze Bushing	4
9	B-33016	Guide Rod	2
10	B-25081	Cover, Guide Rod	4
11	A-25470	Pin	2
12	A-5200-31	Lock Plate	2
13	0323	Hex Head Bolt	4
14	2762	Lock Washer	4
15	3004	Grease Fitting	2
16	7500-64	Cylinder	2
17	SK-7500-64	. Seal Kit	1
18	B-4703-2	Pin	2
19	B-4703-3	Pin	2
20	A-5200-21	Lock Plate	5
21	0187	Hex Head Bolt	8
22	2761	Lock Washer	8
23	7500-109	Cylinder	1
24	SK-7500-64	. Seal Kit	1
25	700103	Pin	1
26	B-4716-2	Pin, Lock	1
27	4730-5	Thrust Washer	2
28	7630	Retaining Ring	2
29	4523-26	Chain	2
30	4543	Clevis Link, Twin	2

FIGURE 15-2. DIRECT DRIVE BROOM HOUSING & REEL

S/N 800300 and Above

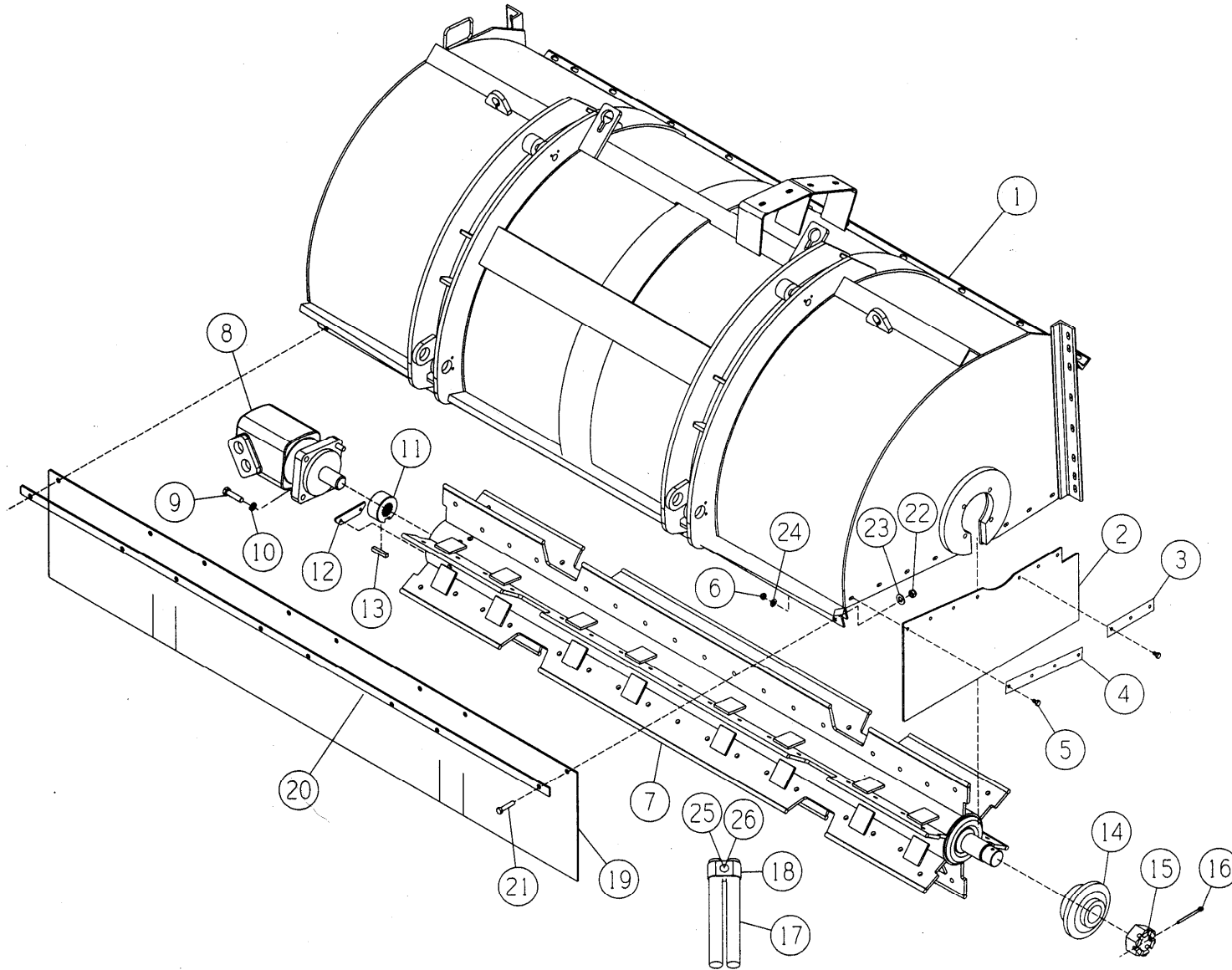
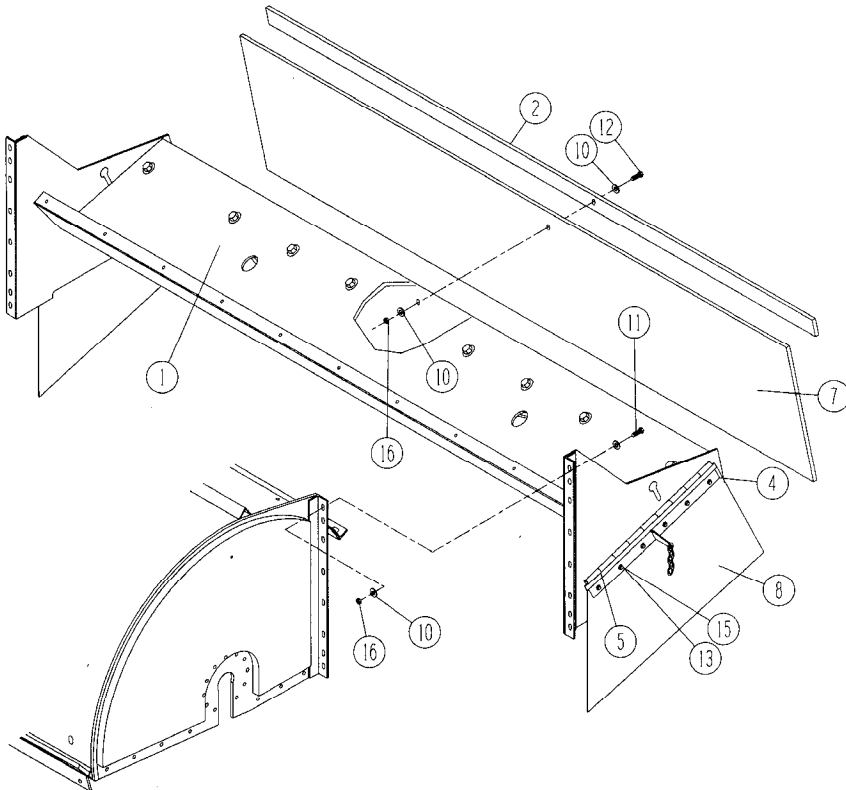


FIGURE 15-2. DIRECT DRIVE BROOM HOUSING & REEL

S/N 800300 and Above

ITEM NO.	NO.	DESCRIPTION	MACHINE	PART	UNITS PER
--	460028	Broom Assembly	1		
1	700034	. Broom Cover	1		
2	680028	. Rubber Skirt.....	2		
3	A-33794	. Rubber Retainer	2		
4	B-33795	. Rubber Retainer	2		
5	0335	. Hex Head Bolt 3/8-16 x 1-3/4	14		
6	2660	. Stover Nut.....	14		
7	700033	Direct Drive Shaft	1		
8	500028	Direct Drive Hydraulic Motor.....	1		
9	0793	Hex Bolt 5/8-11 x 2-3/4	4		
10	?	Lockwasher	4		
11	700048	Splined Bushing.....	1		
12	700049	Keeper Plate.....	1		
13	620034	Direct Drive Key.....	1		
14	620029	Flanged Spherical Roller Bearing.....	1		
15	700066	Castle Nut.....	1		
16	2850	Cotter Pin.....	1		
17A	B-40792	Broom Element (Derby).....	204		
17B	B-40791	Broom Element (U-Nova)	204		
17C	B-27738	Broom Element (Polyco).....	204		
18A	C-27736	Element Clamp (U-Nova and Polyco).....	102		
18B	680000	Element Clamp (Derby)	102		
19	A-40889	Retainer Rubber	1		
20	B-40888	Rubber Skirt.....	1		
21	0559	Bolt 1/2-13 x 1-1/2	8		
22	3042025	Stover Nut, 1/2-13	8		
23	2755-1	½" Alloy Flatwasher	8		
24	2735	3/8" SAE Flatwasher.....	14		
25	2405	5/8" x 4" Bolt	102		
26	2668	Stover Nut, 5/8"	102		
27*	3801230	Grease Fitting	1		
28*	700064	Broom Shaft Cover	1		
27*	0769	HH Bolt 5/8-11 x 1-1/4	3		
28*	2739	SAE 5/8" Flatwasher.....	3		

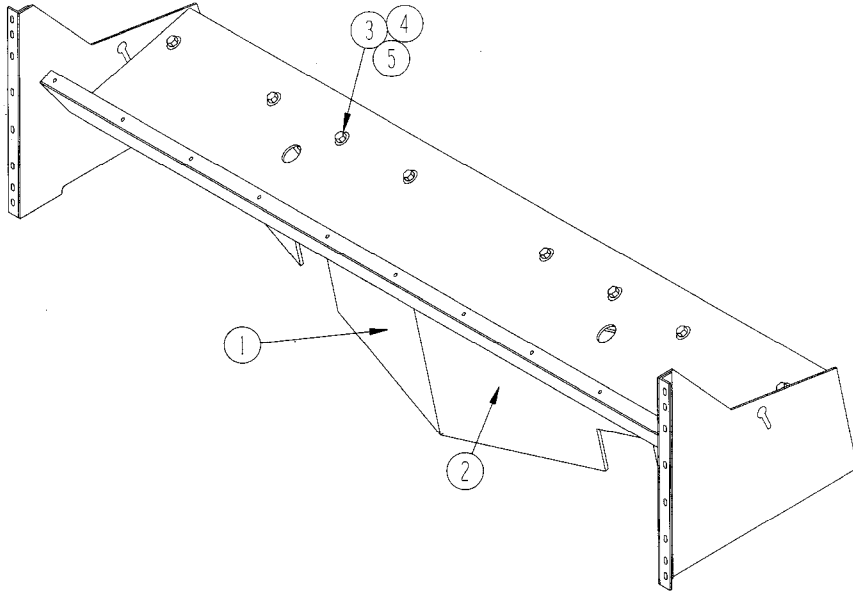
FIGURE 15-3. BROOM Stone Deflector (Optional) S/N 800300 and Above



ITEM NO.	PART NO.	DESCRIPTION	UNITS PER MACHINE
1	D-27697	Stone Deflector Weldment	1
---	D-27681	. Deflector Wrapper	1
2	A-27682	Rubber Retainer (Front)	1
3*	A-25214	Rubber Retainer (Corner Bend)	2
4	A-25237	Rubber Retainer Weldment (Sides)	2
5	C-33345	Hinge Plate Assembly	2
6*	2816	Cotter Pin	4
7	B-27684	Rubber Skirt (Front).....	1
8	B-27679	Rubber Skirt (Sides).....	2
9*	C-33346	Hinge Plate Assembly (Front)	1
10	2755-1	Washer, ½" Flat.....	56
11	0559	Hex Head Bolt	16
12	0563	Hex Head Bolt	28
13	0331	Hex Head Bolt	25
14*	A-25206	Pin	2
15	2660	Stover Nut	25
16	2664	Stover Nut	28

See Figure 15-3-1 For Stone Deflector Cartridge Options

FIGURE 15-3-1. BROOM Stone Deflector Cartridges S/N 800300 and Above



ITEM NO.	PART NO.	DESCRIPTION	UNITS PER MACHINE
---	800045	Mult. V Cartridge Assembly.....	1
1	D-33418	Cartridge, RH	1
2	D-33417	Cartridge LH.....	1
3	0775	Hex Head Bolt	16
4	2668	Stover Nut	16
5	2755-2	Flat Washer, 5/8".....	32
--	800139	Single V Rubber Cartridge Assembly.....	1
1	800138	Cartridge, RH	1
2	800137	Cartridge, LH.....	1
3	0775	Hex Head Bolt	16
4	2668	Stover Nut	16
5	2755-2	Flat Washer, 5/8.....	32
---	800044	Single V Cartridge Assembly	1
1	D-33416	Cartridge, RH	1
	2514	. . Hex Nut	1
	A-33458	. . Plate	1
	A-33549	. . Plate, Hardox	1
2	D-33415	Cartridge, LH.....	1
	2514	. . Hex Nut	1
	A-33458	. . Plate	1
	A-33549	. . Plate, Hardox	1
3	0775	Hex Head Bolt	16
4	2668	Stover Nut	16
5	2755-2	Flat Washer, 5/8.....	32

**FIGURE 15-4. BROOM
Broom Steps (Option)
S/N 800300 and Above**



**FIGURE 17-1. 175" SNOW WINGS
Left (Shown)/Right
S/N 800201 and Above**

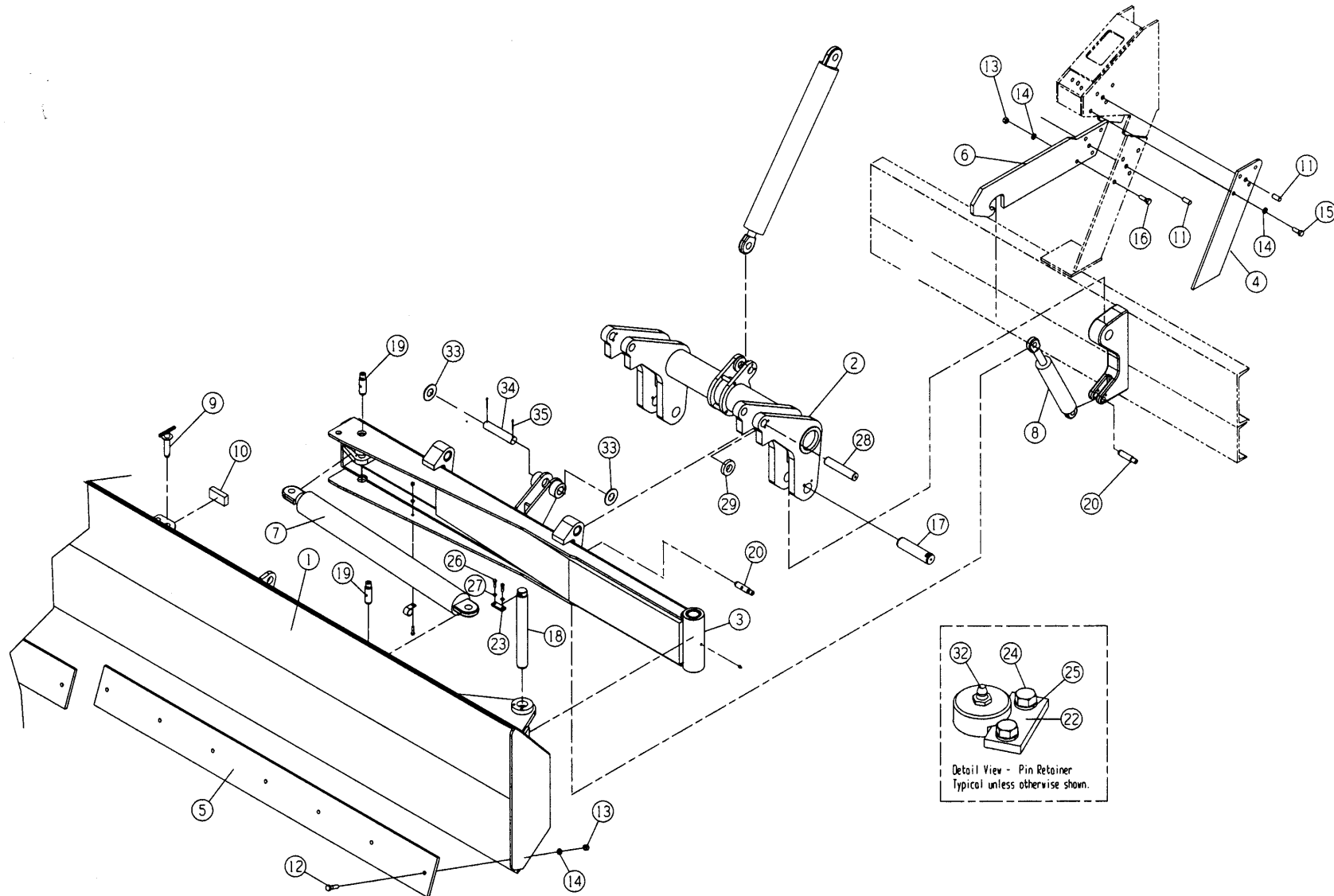


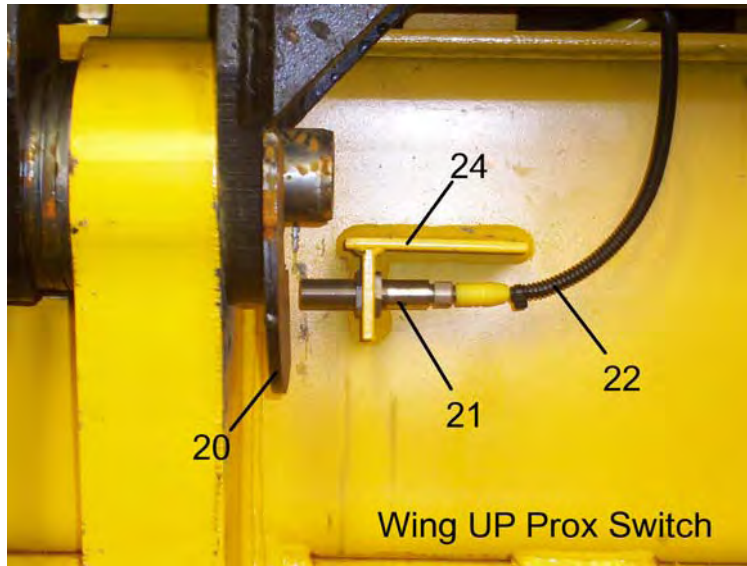
FIGURE 17-1. 175" SNOW WINGS Left (Shown)/Right S/N 800201 and Above

ITEM NO.	PART NO.	DESCRIPTION	UNITS PER MACHINE
1A	D-32302	LH Wing (Shown)	1
1B	D-32303	RH Wing	1
2	802194	Lift Bracket.....	2
3A	802192	LH Support Arm.....	1
3B	802193	RH Support Arm	1
4	A-27556	Plate	2
5	B-32312	Wing Blade	4
6	802196	Plow Hook	2
7	7500-101	Wing Tilt Cylinder	2
--	SK7500-101	. . Seal Kit	1
8	7500-68	Wing Lift/Extend Cylinder	4
--	SK7500-68	. . Seal Kit	1
9	A-27592	Security Pin	2
10	A-27559-6	Shim	2
11	2913	Dowel Pin	4
12	0785	Bolt, Hex 5/8" x 2-1/4 Grade 5.....	28
13	2514	Nut, Hex 5/8"	44
14	2766	Lockwasher, 5/8"	44
15	0777	Bolt, Hex	8
16	0781	Bolt, Hex 5/8" x 2 Grade 5	8
17	A-25790	Pin	4
18	B-4708-3	Pin	1
19	B-4704-10	Pin	4
20	B-4703-2	Pin	8
21	802195	Support Bar	2
22	A-5200-21	Keeper Plate.....	18
23	A-5200-31	Keeper Plate.....	2
24	0187	Bolt, Hex	36
25	2761	Lockwasher	36
26	0327	Bolt, Hex	6
27	2762	Lockwasher	4
28	700283	Pin	2
29	A-27385	Washer	4

ITEM NO.	PART NO.	DESCRIPTION	UNITS PER MACHINE
32	3004	Grease Fitting.....	20
33	2721	Washer, 1-1/2".....	4
34	A-27125	Pin	2
35	2817	Cotter Pin	4
36	3881	Hose Clamp	4
37	0331	Bolt, Hex.....	1
38	2660	Nut, Hex	2
39*	4524x10	Chain 10-Inch Grade 30.....	2
40*	750236	Lockup Cylinder (Optional).....	1

See next page for Snow Wing Prox Switch Info

**FIGURE 17-1. 175” SNOW WINGS
 Left (Shown)/Right
 S/N 800201 and Above**

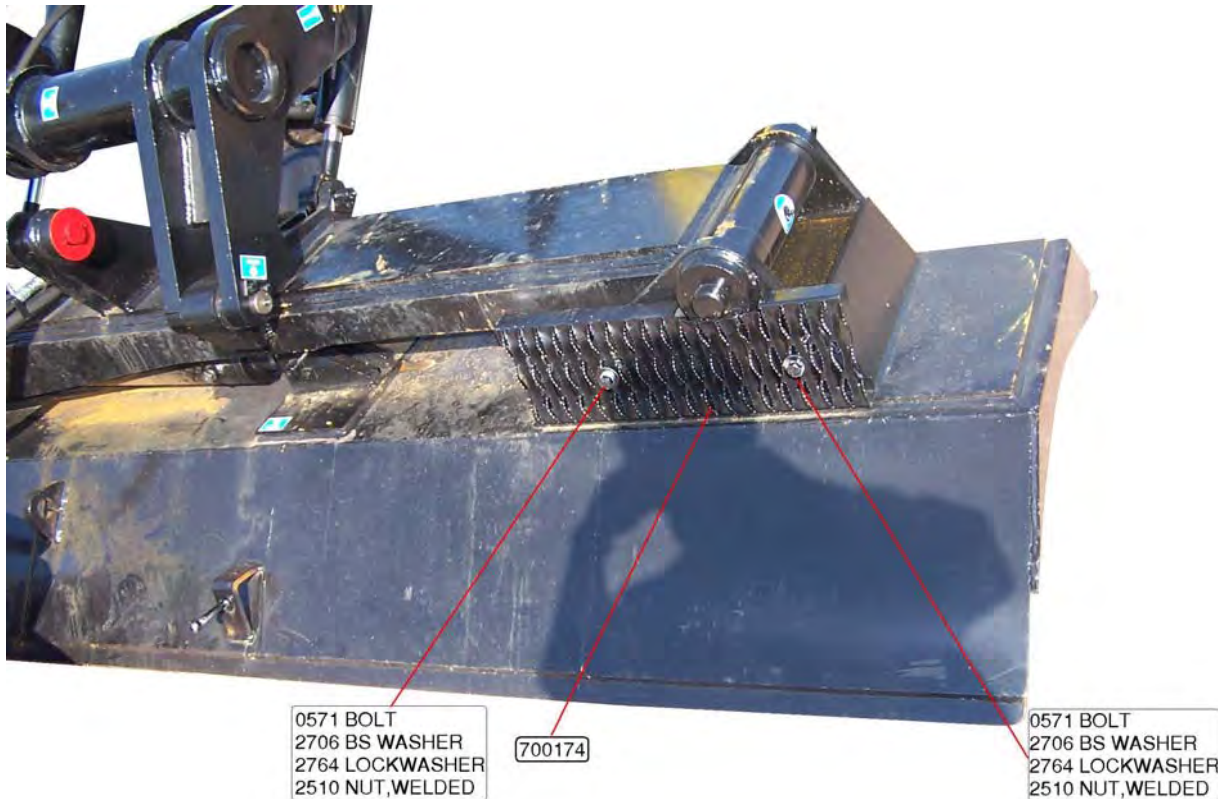


The following items are located on the frame next to the wings and control the Wing UP functions. When switching from ballast to snow wings, item 20A is replaced by 20B.

ITEM NO.	PART NO.	DESCRIPTION	UNITS PER ASSY
20A	700085	Flag, Prox Switch (Summer).....	1
20B	700084	Flag, Prox Switch (Winter).....	1
21	5127411	Switch, Prox	1
22	22311601-060	Cable, Microfast Prox Switch.....	1
24	802072	Prox Switch Mtg. Bracket	1

**FIGURE 17-2. 175" SNOW WINGS
Steps (option)
S/N 800201 and Above**

**Right
Hand**



**FIGURE 17-2. 175" SNOW WINGS
Steps (option)
S/N 800201 and Above**

Left Hand

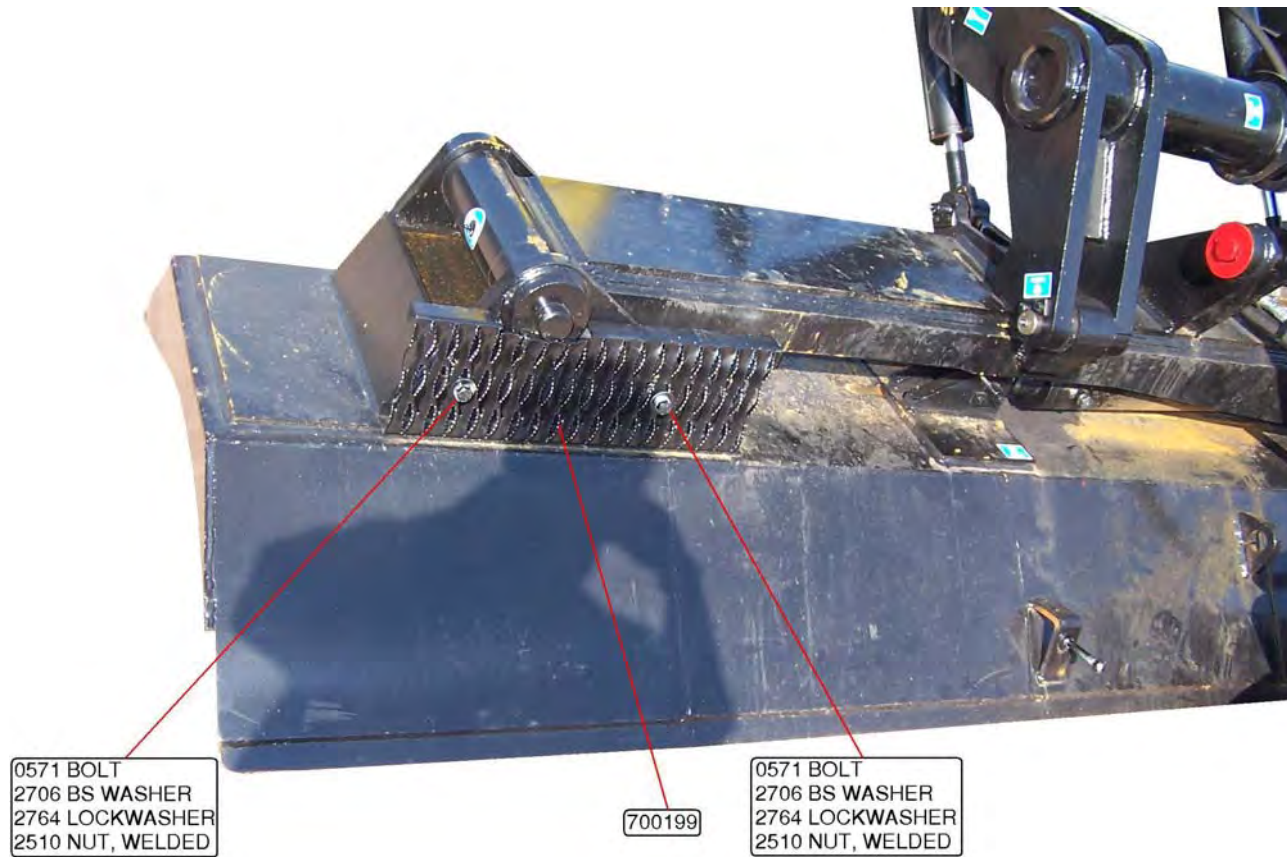


FIGURE 18-1. SNOW SCREW
S/N 800201 and Above

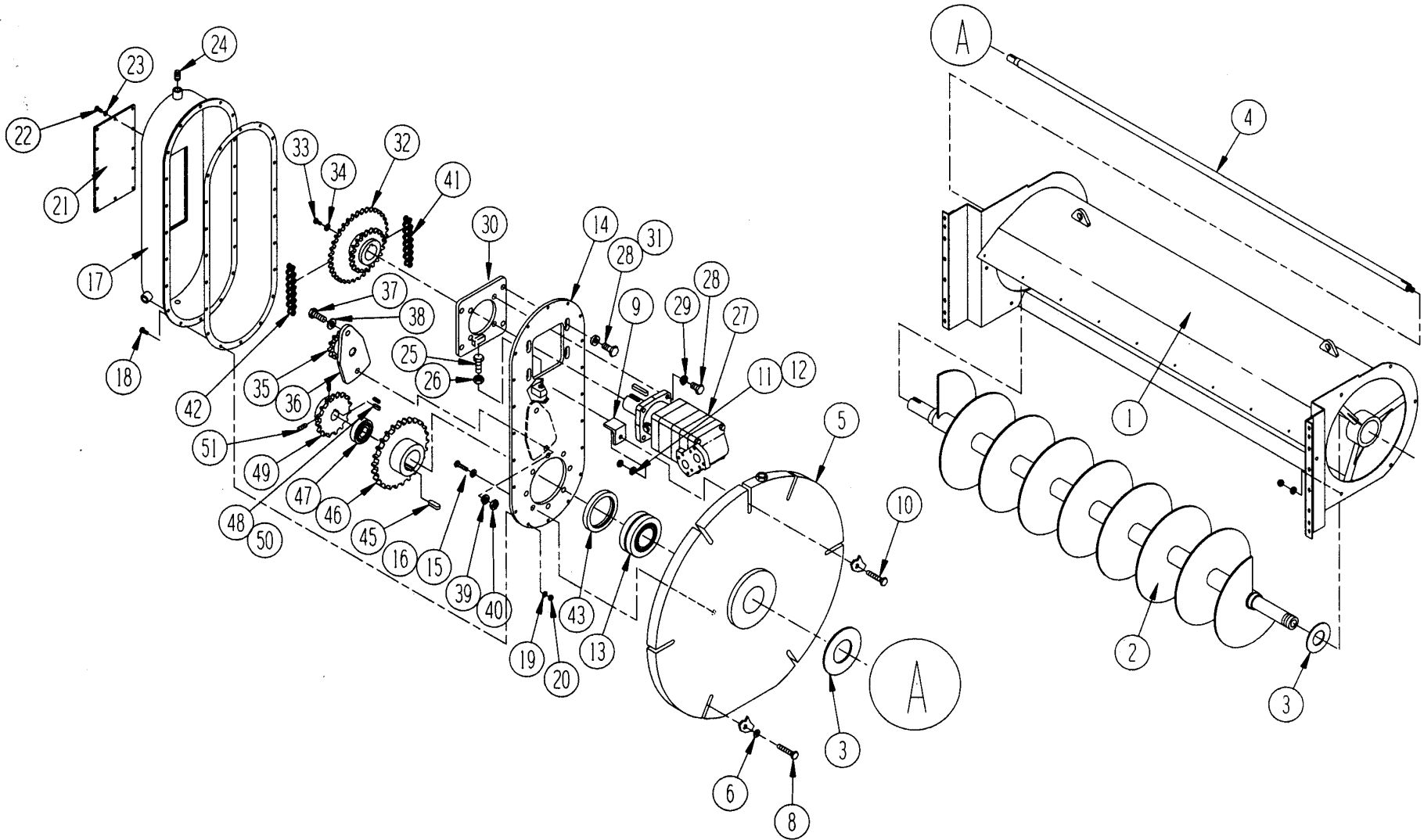


FIGURE 18-1. SNOW SCREW S/N 800201 and Above

ITEM NO.	PART NO.	DESCRIPTION	UNITS PER MACHINE	ITEM NO.	PART NO.	DESCRIPTION	UNITS PER MACHINE
1	D-32911	Screw Cover	1	--	B-32880PROD	Adjuster Assembly	1
--	3006	Grease Fitting	1	35	A-32895	. Sprocket	1
2	D-10342	Screw Conveyor	1	36	B-32881	. Bracket	1
3	B-10344	Flinger	2	37	897	. Hex Bolt 3/4 x 2-3/4	1
4	B-10343	Blower Shaft	1	38	2755-3	3/4" Alloy Flat Washer	1
5	B-33574	Counterweight	1	39	2768	3/4" Lockwasher	1
--	3004	Grease Nipple	1	40	2670	3/4 Stover Nut	1
6	2755-3	3/4" Flat Washer	6	41	4539-68	Chain	1
7	2670	3/4" Stover Nut	6	42	4539-70	Chain	1
8	905	Hex Bolt 3/4 x 3-1/4" Grade 5	6	43	3900-74	Oil Seal	1
9	A-32894	Angle	1	44*	3900-73	Sealing Ring	1
10	591	Hex Bolt 1/2 x 3-1/2 Grade 5	1	45	A-27967	Key	1
11	2737	1/2 SAE Washer	1	46	B-33860	Auger Sprocket Assembly	1
12	2664	1/2" Stover Nut	1	47	4274	Bearing	1
13	4264	Bearing, Shaft	2	48	A-10347	Spacer	1
14	C-32918	Cover Assembly	1	49	C-10346	Blower Sprocket	1
15	771	Hex Bolt 5/8 x 1-1/2 Grade 8	8	50	A-27966	Key	1
16	2755-2	5/8" Flat Washer	8	51	1928	Set Screw	1
17	C-32917	Chain Case	1				
18	0327	Hex Bolt 3/8 x 1-1/4	20				
19	2762	3/8" Lockwasher	20				
20	2506	3/8" Hex Nut	20				
21	B-32885	Cover	1				
22	183	Hex Bolt 5/16 x 5/8"	12				
23	2761	5/16" Lockwasher	12				
24	3636	Square Head Plug	3				
25	2115	Square Head Set Screw	1				
26	2516	Hex Nut	1				
27	F-233	Motor, Hydraulic (Auger Drive)	1				
28	777	Hex Bolt	4				
29	2766	Lockwasher	4				
30	B-32954	Motor Base	1				
31	A-32989	Washer	4				
32	C-33863	Drive Sprocket Assembly	1				
33	558	Hex Bolt 1/2 x 1-1/2	1				
34	2764	1/2" Lockwasher	1				

FIGURE 18-2. SNOW SCREW
 Snow Chute
 S/N 800201 and Above

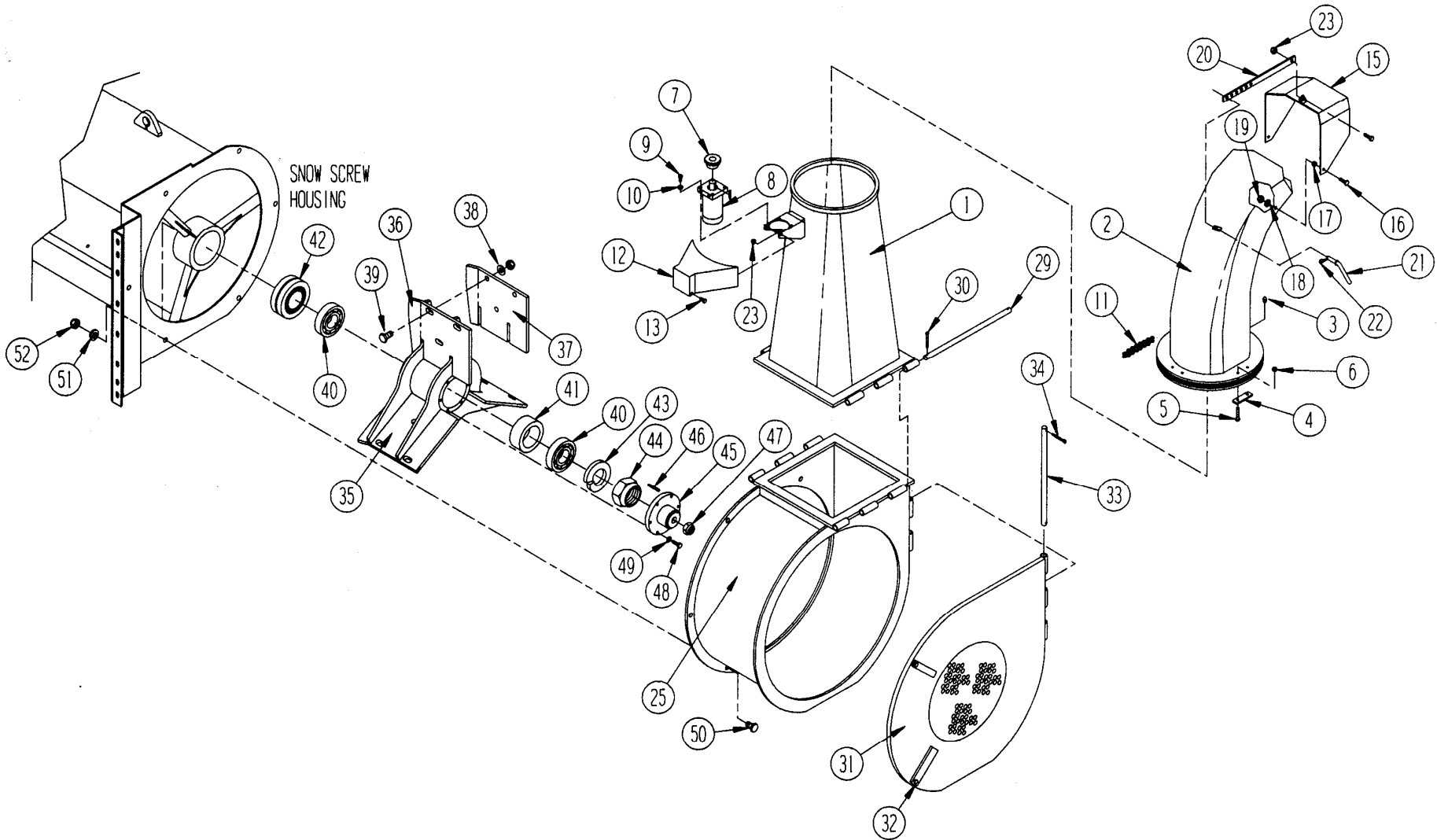


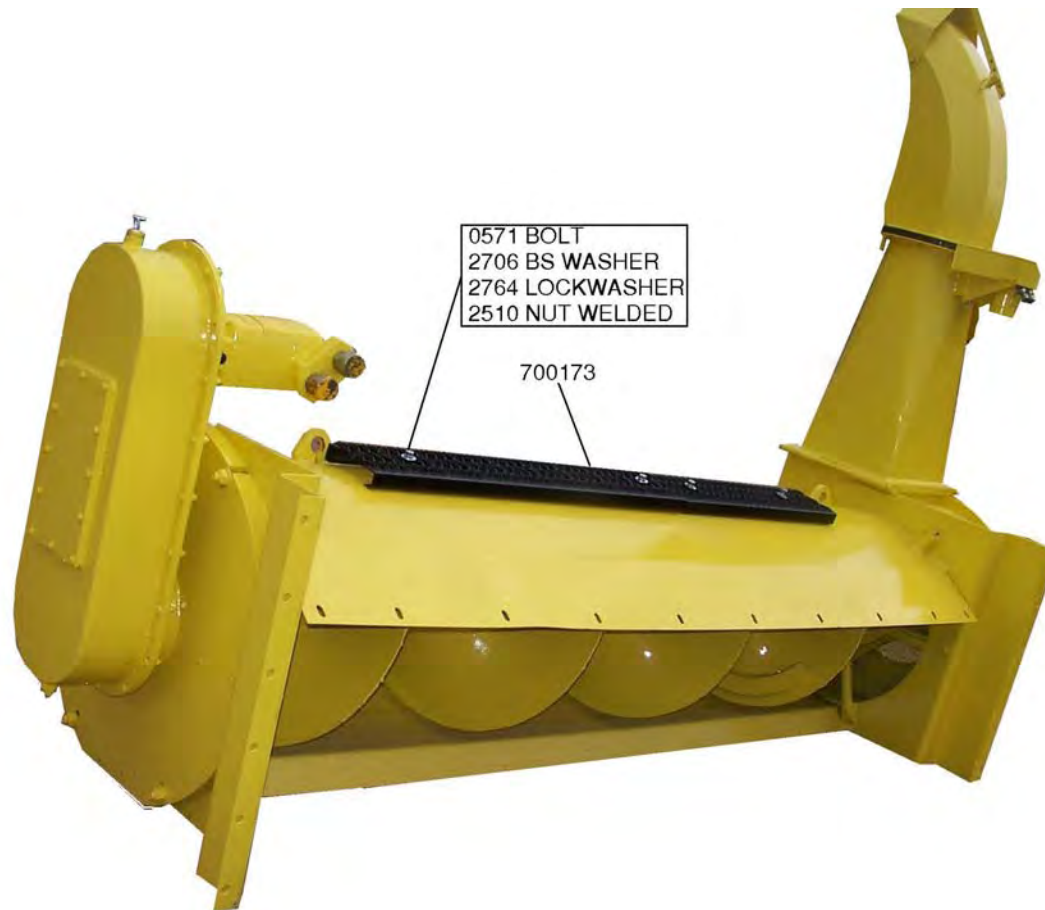
FIGURE 18-2. SNOW SCREW Snow Chute S/N 800201 and Above

ITEM NO.	PART NO.	DESCRIPTION	UNITS PER MACHINE
1	0218-2500	Chute Base.....	1
2	0218-2300	Discharge Chute.....	1
3	3004	Grease Nipple.....	3
4	0218-0800	Retaining Plate.....	4
5	0087	Hex Bolt ¼ x 2.....	8
6	2656	Lock Nut ¼".....	8
7	6721	Chain Sprocket.....	1
8	F-201	Motor, Hydraulic (Chute Rotate).....	1
9	0323	Hex Bolt 3/8 x 1.....	8
10	2762	Lock Washer.....	4
11	4538-92	Chain.....	1
12	0218-1000	Chain Guard.....	1
13	0323	Hex Bolt 3/8 x 1.....	4
14	2762	Lock Washer.....	4
15	0218-3400	Deflector Hood.....	1
16	0075	Hex Bolt ¼ x 1-1/4.....	2
17	A-33640	Spacer.....	2
18	2734	5/16" SAE Flat Washer.....	2
19	2656	Lock Nut.....	2
20	0218-3500	Adjusting Bar.....	1
21	A-32892	Pin Assembly.....	1
22	2874-3	Hitch Pin Clip.....	1
23	2660	Lock Nut.....	1
24	331	Hex Bolt.....	1
25	0218-2200	Blower Housing.....	1
26	2737	½ SAE Washer.....	6
27	2664	Lock Nut.....	6
28	563	Hex Bolt.....	6
29	0218-2900	Hinge Pin.....	2
30	2797	Cotter Pin.....	4
31	C-33535	Inspection Cover.....	1
32	A-7315	Locking Handle.....	2
33	0218-3600	Hinge Pin.....	2
34	2797	Cotter Pin.....	2

ITEM NO.	PART NO.	DESCRIPTION	UNITS PER MACHINE
35	D-33135	Blower Propeller.....	1
36	C-33137	Plate.....	3
37	C-33138	Propeller Blade.....	3
38	2755-2	Flat Washer.....	9
39	801	Hex Bolt.....	9
40	4200-3	Bearing.....	2
41	0218-0600	Spacer.....	1
42	7612	Retaining Ring.....	2
43	7024	Lock Washer.....	1
44	7309	Locknut.....	1
45	0218-3000	Flange.....	1
46	A-27968	Key.....	1
47	2675	Lock Nut.....	1
48	0327	Hex Bolt.....	27
49	2762	Lock Washer.....	10
50	0559	Hex Bolt.....	16
51	2755-1	Hardened Washer.....	15
52	2664	Lock Nut.....	22
53	2668	Lock Nut (Goes w/Blade).....	9
*	2729 9279	Tarp, Discharge Chute.....	1
*	3104 491	Screw, Sheet Metal.....	10

ⓘ Service Required Monthly November through March

**FIGURE 18-3. SNOW SCREW
Housing Steps (Option)
S/N 800201 and Above**



**FIGURE 18-4. SNOW SCREW
Toolbox (Option)
S/N 800201 and Above**

