

**Operation Manual**

**B/F L 1011F**

**B/FM 1011F**



1 Gerade



## Safety guidelines / Accident prevention

- Please read and observe the information given in this Operation Manual. This will enable you to avoid accidents, preserve the manufacturer's warranty and maintain the engine in peak operating condition.
- This engine has been built exclusively for the application specified in the scope of supply, as described by the equipment manufacturer and is to be used only for the intended purpose. Any use exceeding that scope is considered to be contrary to the intended purpose. The manufacturer will not assume responsibility for any damage resulting therefrom. The risks involved are to be borne solely by the user.
- Use in accordance with the intended purpose also implies compliance with the conditions laid down by the manufacturer for operation, maintenance and servicing. The engine should only be operated by personnel trained in its use and the hazards involved.
- The relevant accident prevention guidelines and other generally accepted safety and industrial hygiene regulations must be observed.
- When the engine is running, there is a risk of injury through:
  - turning/hot components
  - engines with positive ignition
  - ignition systems (high electrical voltage)You must avoid contact at all times!
- Unauthorized engine modifications will invalidate any liability claims against the manufacturer for resultant damage. Manipulations of the injection and regulating system may also influence the performance of the engine, and its emissions. Adherence to legislation on pollution cannot be guaranteed under such conditions.
- Do not change, convert or adjust the cooling air intake area to the blower. The manufacturer shall not be held responsible for any damage which results from such work.
- When carrying out maintenance/repair operations on the engine, the use of DEUTZ original parts is prescribed. These are specially designed for your engine and guarantee perfect operation. Non-compliance results in the expiry of the warranty!
- Maintenance and cleaning of the engine should only be carried out when the engine is switched off and has cooled down. You must ensure that the electrical systems have been switched off and the ignition key has been removed. Accident prevention guidelines concerning electrical systems (e.g. VDE-0100/-0101/-0104/-0105 Electrical protective measures against dangerous touch voltage) are to be observed. When cleaning with fluids, all electrical components are to be covered impermeably.

## Operation Manual

# B/F L 1011F B/FM 1011F

## 0297 9683 en

Engine Serial Number

--	--	--	--	--	--	--	--	--	--

Please enter the engine serial number here. This number should be quoted when inquiring about Customer Service, Repairs or Spare Parts (see Section 2.1). All rights reserved. Technical modifications required to improve our engines are reserved with regard to speci-

fication data and other technical information contained in this Operation Manual. No parts of this Manual may be reproduced in any form or by any means without our written approval.



3 Gerade



# Foreword

---

Dear Customer,

Air / liquid-cooled DEUTZ engines are designed for a large number of applications. Consequently, a wide range of variants are offered to meet the requirements of specific cases.



Your engine is appropriately equipped for the installation concerned, which means that not all of the components described in this Operation Manual are necessarily mounted to your engine.

We have endeavored to highlight any differences so that you will be able to locate the operating and maintenance instructions relevant to your engine quickly and easily.

Please read this Manual before starting your engine, and always observe the operating and maintenance instructions.

We are available to help with any additional inquiries

Sincerely,  
DEUTZ AG



# Index

1

- 1 General**
- 2 Engine Description**
  - 2.1 Model
    - 2.1.1 Rating Plate
    - 2.1.2 Rating Plate Location
    - 2.1.3 Engine Serial Number
    - 2.1.4 Cylinder Numbering
    - 2.1.5 Fuel Delivery Lock
  - 2.2 Engine Illustrations
    - 2.2.1 Service Side FL 1011F
    - 2.2.2 Exhaust Side FL 1011F
    - 2.2.3 Service Side BFL 1011F
    - 2.2.4 Exhaust Side BFL 1011F
    - 2.2.5 Service Side FM 1011/ F
    - 2.2.6 Exhaust Side FM 1011/ F
    - 2.2.7 Service Side BFM 1011F
    - 2.2.8 Exhaust Side BFM 1011F
  - 2.3 Oil Circuit
    - 2.3.1 Lube Oil Circuit
  - 2.4 Fuel System Schematic
    - 2.4.1 Fuel System
- 3 Engine Operation**
  - 3.1 Commissioning
    - 3.1.1 Adding Engine Oil
    - 3.1.2 Filling oil bath air filter with engine oil
    - 3.1.3 Adding Fuel
    - 3.1.4 Other Preparations
    - 3.1.5 Additional Maintenance Work
  - 3.2 Starting
    - 3.2.1 Starting
  - 3.3 Monitoring Systems
    - 3.3.1 Engine Oil Pressure
    - 3.3.2 Coolant Temperature
  - 3.4 Stopping
    - 3.4.1 Mechanical Shutdown
    - 3.4.2 Electrical Shutdown
- 3.5 Operating Conditions
  - 3.5.1 Winter Operation
  - 3.5.2 High Ambient Temperature, High Altitude
- 4 Operating Media**
  - 4.1 Lube Oil
    - 4.1.1 Quality Grade
    - 4.1.2 Viscosity
  - 4.2 Fuel Operating Media
    - 4.2.1 Quality Grade
    - 4.2.2 Winter-Grade Fuel
- 5 Routine Maintenance**
  - 5.1 Maintenance Schedule
  - 5.2 Maintenance Chart
  - 5.3 Maintenance Work Completed
- 6 Service and Maintenance**
  - 6.1 Lubrication System
    - 6.1.1 Oil Change Intervals
    - 6.1.2 Changing Engine Oil, Check Oil Level
    - 6.1.3 Changing Oil Filter
  - 6.2 Fuel System
    - 6.2.1 Changing Fuel Filter
    - 6.2.2 Clean Strainer of Fuel Filter
    - 6.2.3 Change Fuel Leakage Line
  - 6.3 Cooling System
    - 6.3.1 Cleaning Intervals
  - 6.4 Combustion Air Cleaner
    - 6.4.1 Cleaning Intervals
    - 6.4.2 Emptying Cyclone Type Precleaner
    - 6.4.3 Cleaning Oil Bath Air Cleaner
    - 6.4.4 Dry Type Air Cleaner
  - 6.5 Belt Drives
    - 6.5.1 Checking V-Belts
    - 6.5.2 Tensioning V-Belts
- 6.5.3 Changing V-Belts
- 6.6 Adjustments
  - 6.6.1 Checking / Adjusting Valve Clearances
- 6.7 Accessories
  - 6.7.1 Battery
  - 6.7.2 Three-Phase Alternator
  - 6.7.3 Lifting Tackle
  - 6.7.4 Ether Starting System
  - 6.8.1 Engine Cleaning
- 7 Troubleshooting**
  - 7.1 Diagnostic chart
- 8 Engine Preservation**
  - 8.1 Preservation
    - 8.1.1 Preserving Engine
    - 8.1.2 Removing Engine Preservations
- 9 Technical Specification**
  - 9.1 Engine Specifications and Settings
  - 9.2 Torque Wrench Settings
  - 9.3 Tools
- 10 Service**

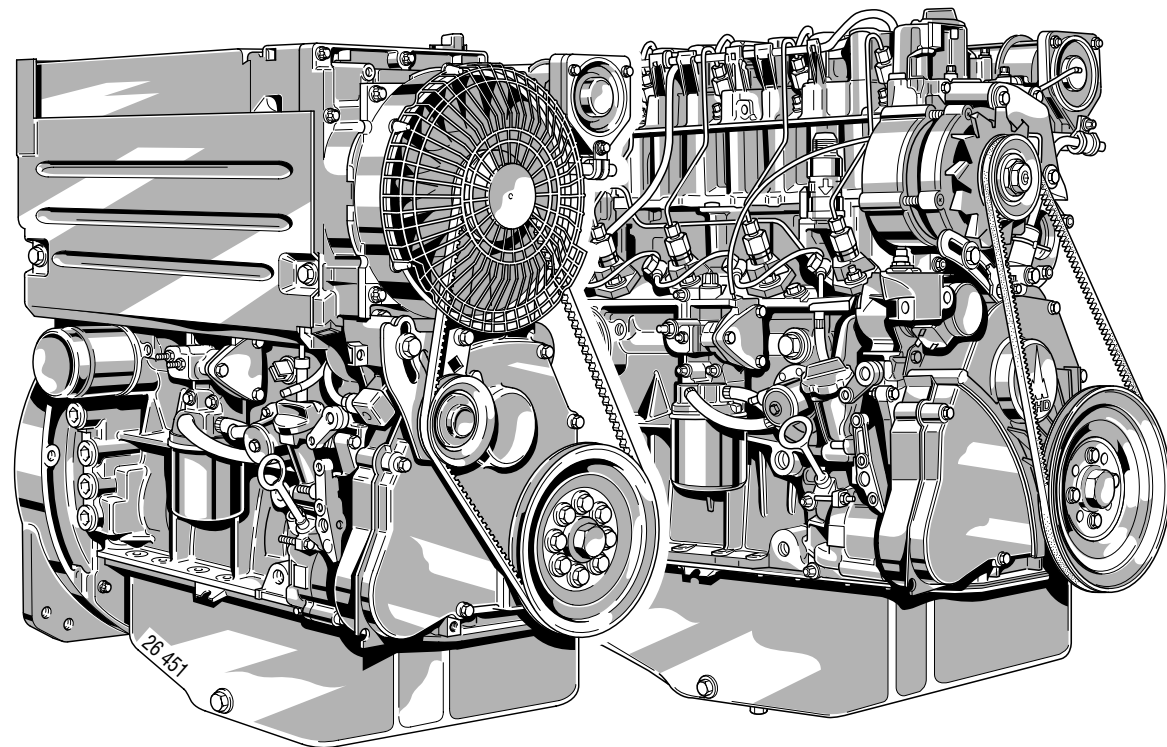



# General

1

## DEUTZ Diesel Engines

are the product of many years of research and development. The resulting know-how, coupled with stringent quality standards, guarantee their long service life, high reliability and low fuel consumption. It goes without saying that DEUTZ Diesel Engines meet the highest standards for environmental protection.

## Care and Maintenance

Sound care and maintenance practices will ensure that the engine continues to meet the requirements placed on it. Recommended service intervals must be observed and service and maintenance work carried out conscientiously. Special care should be taken under abnormally demanding operating conditions.

## Service

Please contact one of our authorized service representatives in the event of breakdowns or for spare parts inquiries. Our trained specialists will carry out repairs quickly and professionally, using only genuine spare parts. Original parts from DEUTZ AG are always produced in accordance with state-of-the-art technology. Please turn to the end of this manual for further service information.

## Beware of Running Engine

Shut the engine down before carrying out maintenance or repair work. Ensure that the engine cannot be accidentally started. Risk of accidents. When the work is complete, be sure to refit any panels and guards that may have been removed. Never fill the fuel tank while the engine is running. Observe industrial safety regulations when running the engine in an enclosed space or underground.

## Safety



This symbol is used for all safety warnings. Please follow them carefully. The attention of operating personnel should be drawn to these safety instructions. General safety and accident prevention regulations laid down by law must also be observed.

**California  
Proposition 65 Warning**

Diesel engine exhaust and some of its constituents are known to the State of California to cause cancer, birth defects, and other reproductive harm.

## Asbestos



DEUTZ original parts are asbestos-free.

7 Gerade





1



8

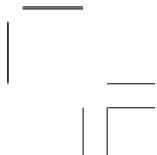



## Engine Description

2

- 2.1 Model**
- 2.2 Engine Illustration**
- 2.3 Lube Oil Circuit Schematic**
- 2.4 Fuel System Schematic**

# Engine Description

## 2.1 Model

### 2

#### 2.1.1 Rating Plate

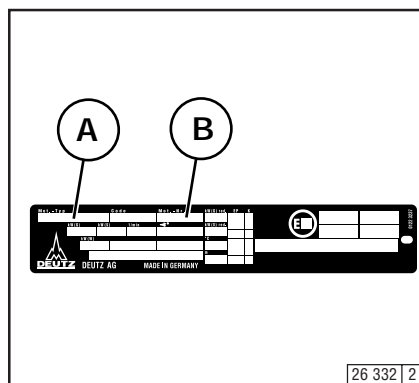

The model **A**, the engine serial number **B** and the performance data are stamped on the rating plate. The model and engine serial number must be given when ordering parts.

#### 2.1.2 Rating Plate Location

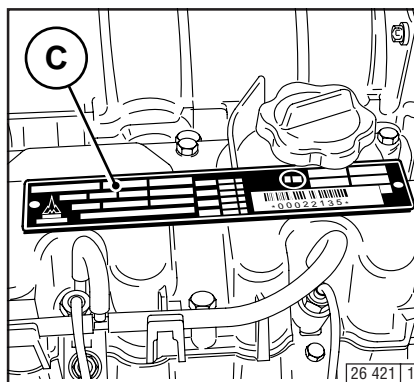

The rating plate **C** is attached to the valve cover.

#### 2.1.3 Engine Serial Number

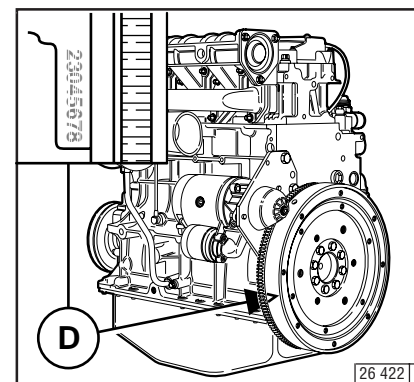

The engine serial number **B** is stamped on the crankcase **D** as well as the rating plate.

## 2.1 Model

## Engine Description

### 2.1.4 Cylinder Numbering

### 2.1.5 Fuel Delivery Lock

2

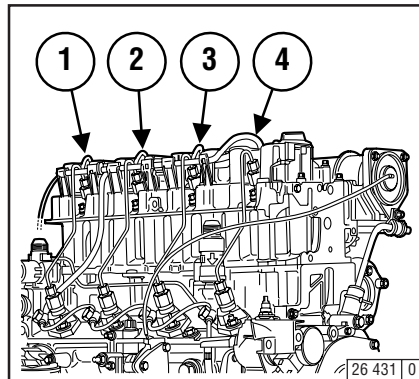

Cylinders are numbered consecutively, beginning at the flywheel end.

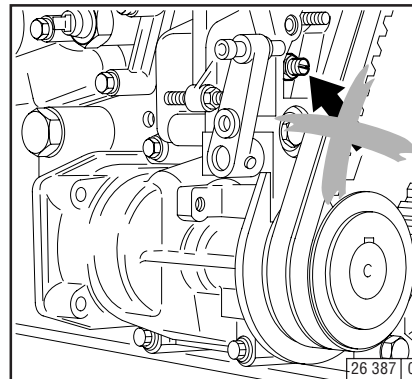

The manufacturer shall not be held liable for damages resulting from adjustments made to the regulator by the operator.  
The lock screws are protected in order to prevent this:

1. with locking paint on model:  
torque balancer
2. with plastic protective cap on model:  
without torque balancer.



Adjustments to the regulator are to be carried out only by authorized DEUTZ SERVICE - specialists.

## Engine Description

2

### 2.2.1 Service Side FL 1011F

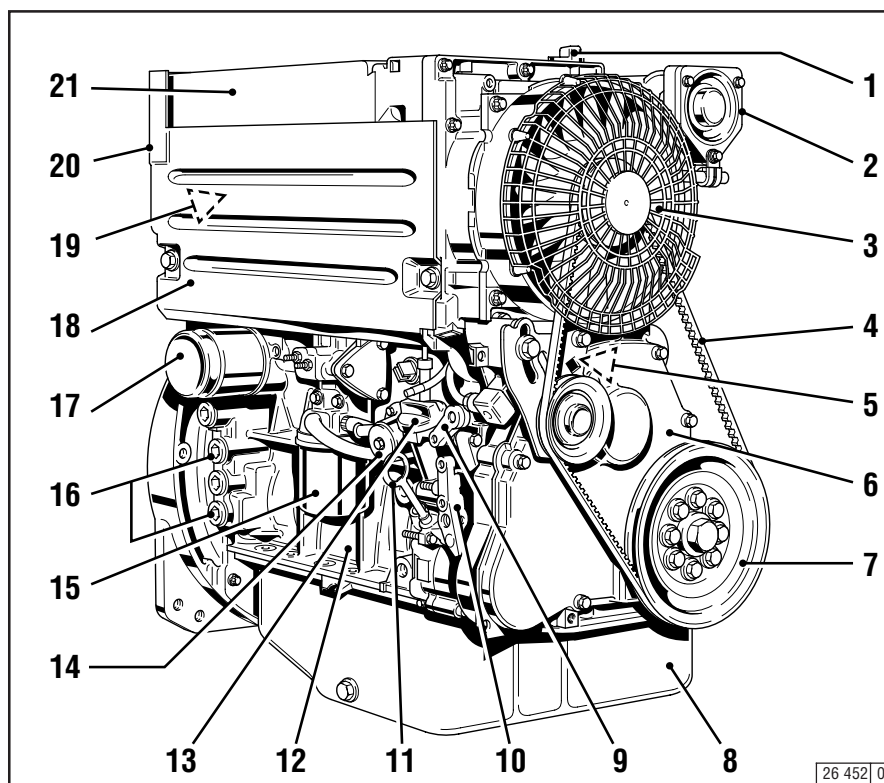

- 1 Oil filler neck (valve-gear cover)
- 2 Charge-air line / air-intake line
- 3 Fan with integrated generator
- 4 Narrow V-belt
- 5 Solenoid
- 6 Toothed belt cover
- 7 V-belt pulley on crankshaft
- 8 Oil sump
- 9 Cut-out handle
- 10 Speed control lever
- 11 Oil dipstick
- 12 Crankshaft housing
- 13 Oil fill point (on side of crankcase)
- 14 Fuel pump
- 15 Easy-change fuel filter
- 16 Connecting facility for oil heater
- 17 Lube oil easy-change filter
- 18 Removable coolant intake hood
- 19 Injection pumps
- 20 Date plate
- 21 Oil cooler

## 2.2 Engine Illustrations

## Engine Description

2

### 2.2.2 Exhaust side FL 1011F

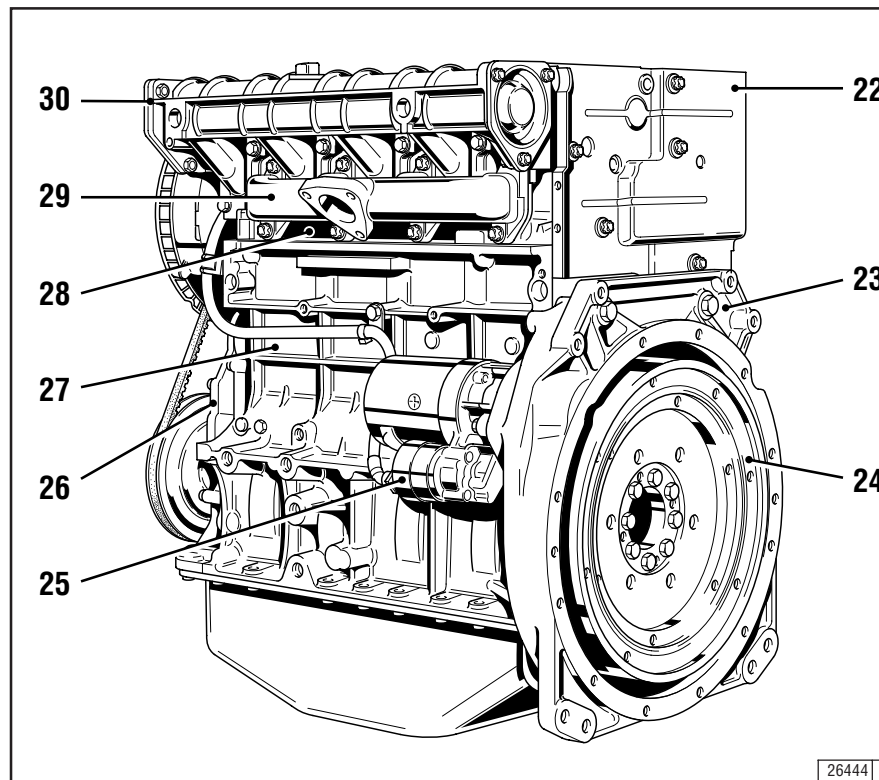

- 22 Date plate
- 23 Connection housing (SAE)
- 24 Flywheel with ring gear
- 25 Starter
- 26 Front cover
- 27 Crankcase
- 28 Cylinder head
- 29 Exhaust manifold pipe
- 30 Air-intake pipe

## Engine Description

## 2.2 Engine Illustrations

2

### 2.2.3 Service Side BFL 1011F

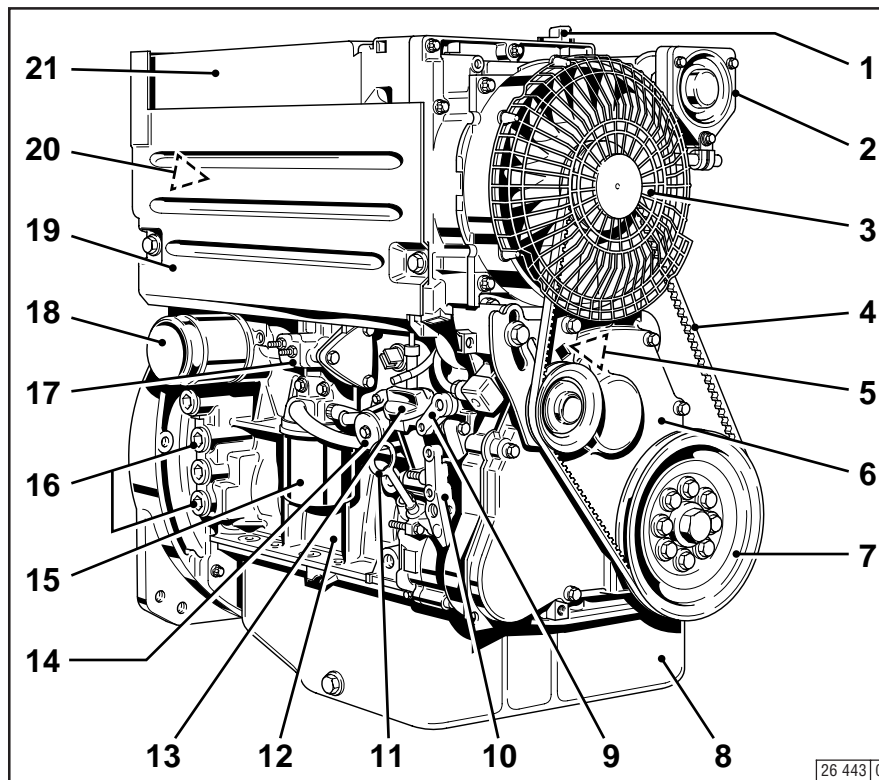

- 1 Oil filler neck (valve-gear housing cover)
- 2 Charge-air line / air-intake line
- 3 Fan with integrated generator
- 4 Narrow V-belt
- 5 Solenoid
- 6 Wheel-house cover
- 7 V-belt pulley on crankshaft
- 8 Oil sump
- 9 Cut-out handle
- 10 Speed control lever
- 11 Oil dipstick
- 12 Crankshaft housing
- 13 Oil fill point (on side of crankcase)
- 14 Fuel pump
- 15 Easy-change fuel filter
- 16 Connection facility for oil heater
- 17 Charge-air pressure full-load stop (LDA)
- 18 Lube oil easy-change filter
- 19 Removable coolant intake hood
- 20 Injection pumps
- 21 Oil cooler

## 2.2 Engine Illustrations

## Engine Description

2

### 2.2.4 Exhaust side BFL 1011F

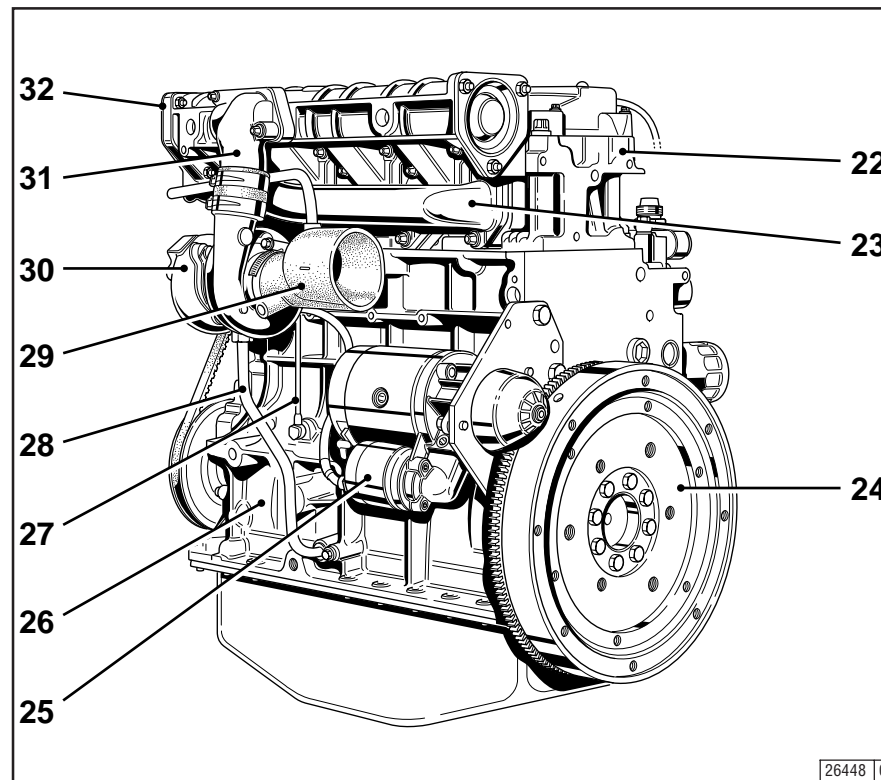

- 22 Cylinder head
- 23 Exhaust manifold pipe
- 24 Flywheel with ring gear
- 25 Starter
- 26 Crankshaft housing
- 27 Inlet line to TC (Lube oil)
- 28 Return line from TC (Lube oil)
- 29 Induction pipe
- 30 Turbocharger (TC)
- 31 Intake manifold
- 32 Air-intake line

15

15 Gerade

## Engine Description

## 2.2 Engine Illustrations

2

### 2.2.5 Service Side FM 1011F

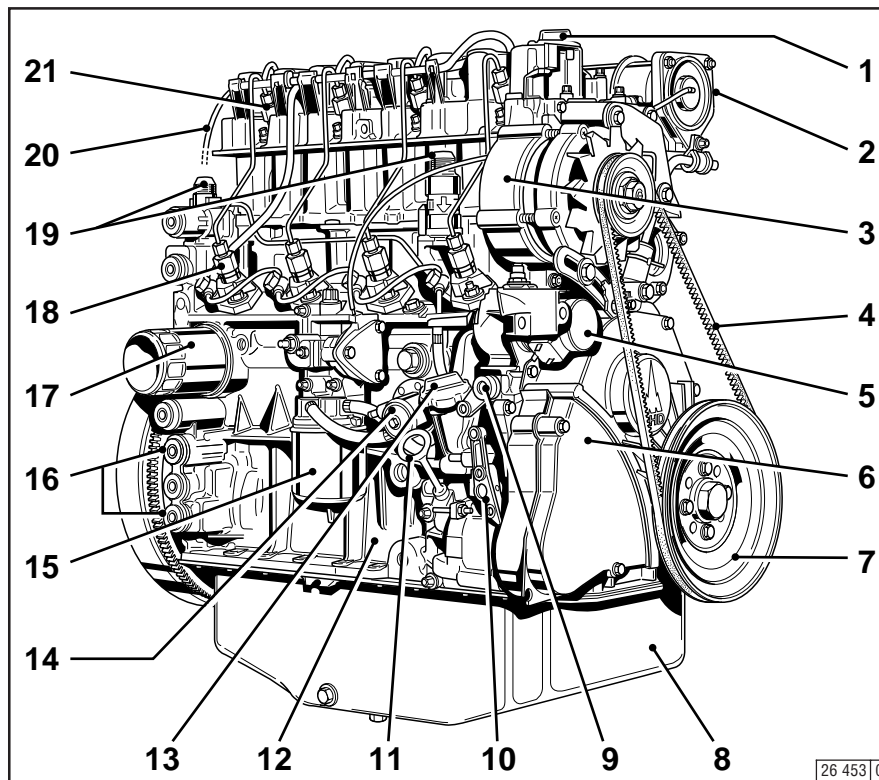

- 1 Oil filler neck (valve-gear housing)
- 2 Charge-air line / air-intake line
- 3 Generator
- 4 Narrow V-belt
- 5 Solenoid
- 6 Wheel-house cover
- 7 V-belt pulley on crankshaft
- 8 Oil sump
- 9 Cut-out handle
- 10 Speed control lever
- 11 Oil dipstick
- 12 Crankshaft housing
- 13 Oil fill point (on side of crankcase)
- 14 Fuel pump
- 15 Easy-change fuel filter
- 16 Connecting facility for oil heater
- 17 Lube oil easy-change filter
- 18 Injection pumps
- 19 Connection for oil cooler
- 20 Leakage-fuel line
- 21 Injection valves



## 2.2 Engine Illustrations

## Engine Description

### 2.2.6 Exhaust side FM 1011F

2

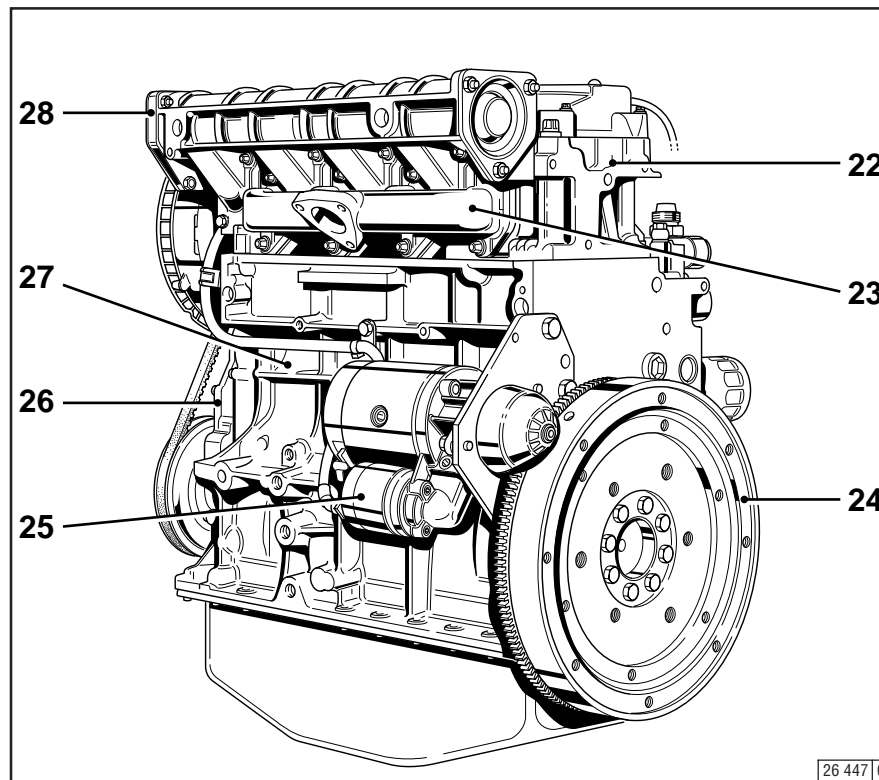

- 22 Cylinder head
- 23 Exhaust manifold line
- 24 Flywheel with ring gear
- 25 Starter
- 26 Front cover
- 27 Crankcase
- 28 Intake pipe

## Engine Description

## 2.2 Engine Illustrations

2

### 2.2.7 Service Side BFM 1011F

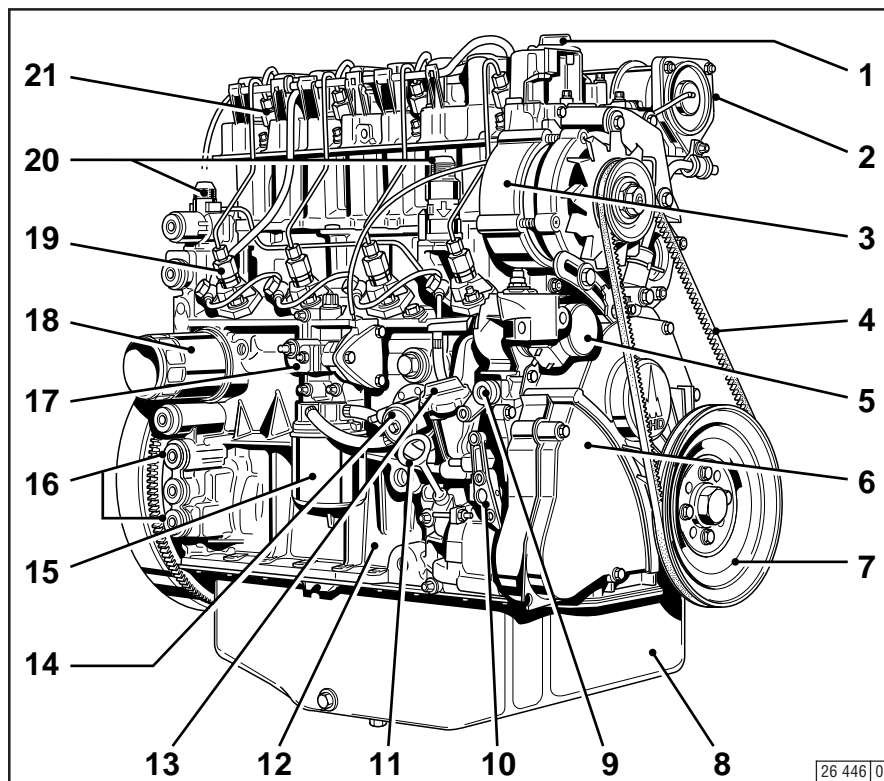

- 1 Oil filler neck (valve-gear housing cover)
- 2 Charge-air line / air-intake line
- 3 Generator
- 4 Narrow V-belt
- 5 Solenoid
- 6 Wheel-house cover
- 7 V-belt on crankshaft
- 8 Oil sump
- 9 Cut-out handle
- 10 Speed control lever
- 11 Oil dipstick
- 12 Crankshaft housing
- 13 Oil fill point (on side of crankcase)
- 14 Fuel pump
- 15 Easy-change fuel filter
- 16 Connecting facility for oil heater
- 17 Charge-air pressure full-load stop (TC)
- 18 Lube oil easy-change
- 19 Injection pumps
- 20 Oil cooler connection
- 21 Injection valves

## 2.2 Engine Illustrations

## Engine Description

2

### 2.2.8 Exhaust side BFM 1011F

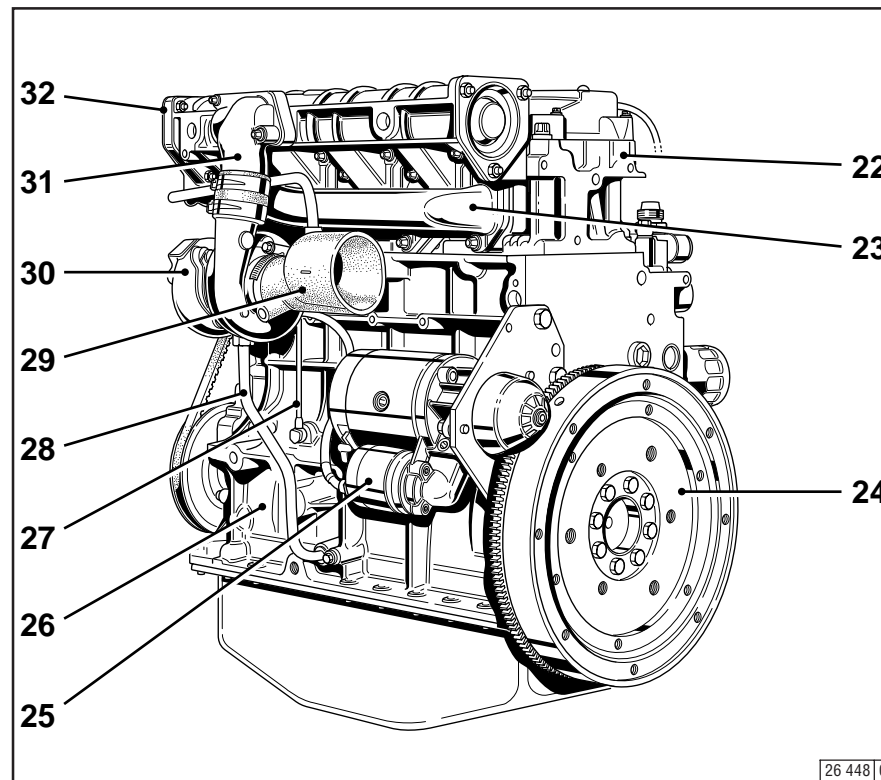

- 22 Cylinder head
- 23 Exhaust manifold pipe
- 24 Flywheel with ring gear
- 25 Starter
- 26 Crankshaft housing
- 27 Inlet line to TC (Lube oil)
- 28 Return line from TC (Lube oil)
- 29 Induction pipe
- 30 Turbocharger (TC)
- 31 Intake manifold
- 32 Air-intake line

## Engine Description

## 2.3 Oil Circuit

2

### 2.3.1 Lube Oil Circuit Schematic

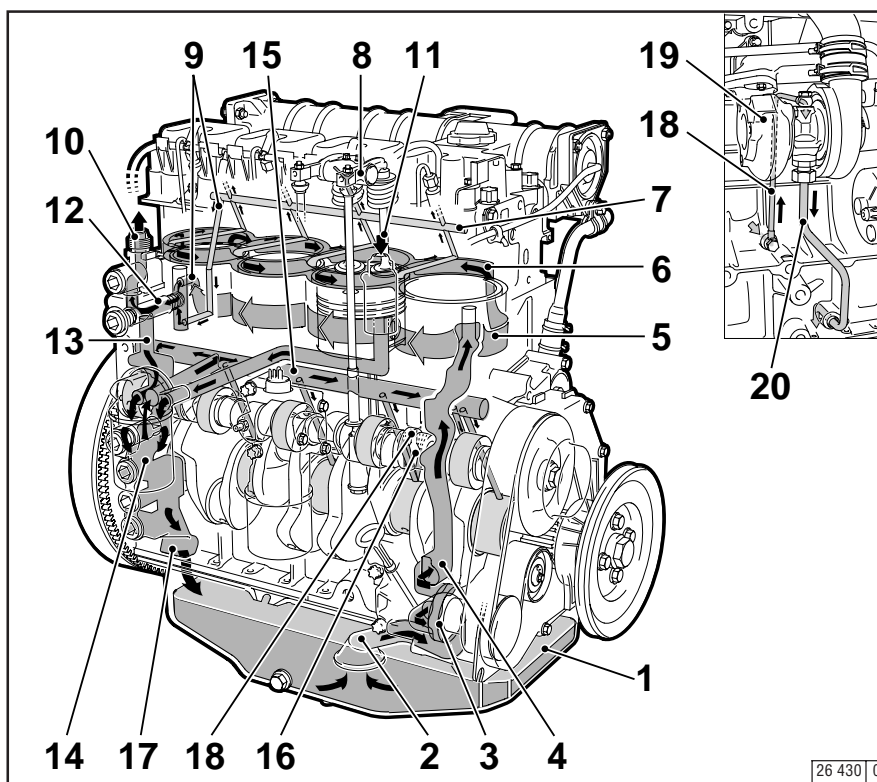

- 1 Oil sump
- 2 Intake manifold
- 3 Oil pump
- 4 Main oil duct
- 5 Oil-cooled cylinder
- 6 Cylinder head cooling neck
- 7 Oil duct for rocker arm lubrication
- 8 Rocker arm
- 9 Oil manifold for the thermostat
- 10 Intake to external engine oil cooler
- 11 Return from external engine oil cooler
- 12 Thermostat housing with slide thermostat
- 13 Oil duct to oil filter
- 14 Oil filter
- 15 Oil duct to the cam, con-rod and crankshaft bearing
- 16 Injection jet for cooling the pistons
- 17 Oil return via crankcase to the oil sump
- 18 Lube oil intake to turbocharger
- 19 Turbocharger
- 20 Return from turbocharger to oil sump

20

## 2.4 Fuel System

## Engine Description

### 2.4.1 Fuel system schematic

2

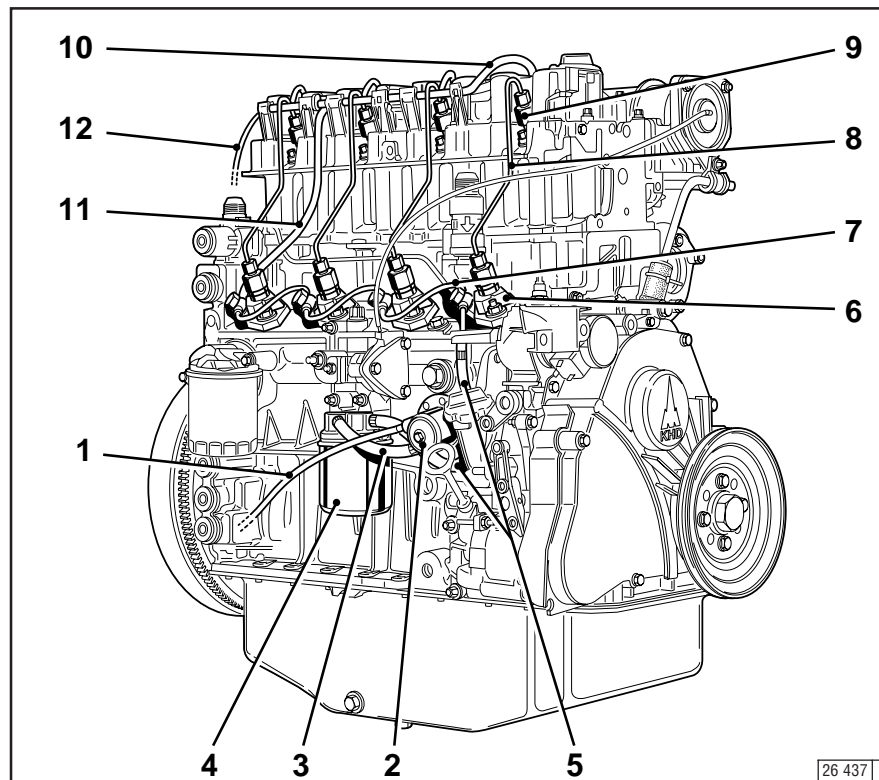

- 1 Fuel line from tank to fuel pump
- 2 Fuel pump
- 3 Fuel line from fuel pump to easy-change fuel filter
- 4 Easy-change fuel filter
- 5 Fuel line from filter to injection pump
- 6 Injection pumps
- 7 Fuel distributor line
- 8 Injection lines
- 9 Injection valves
- 10 Fuel leakage line
- 11 Fuel overflow pipe
- 12 Fuel return line to tank

21

21 Gerade

- 3.1 Commissioning**
- 3.2 Starting**
- 3.3 Monitoring Systems**
- 3.4 Stopping**
- 3.5 Operating Conditions**

# Engine Operation

## 3.1 Commissioning

### 3

#### 3.1.1 Adding Engine Oil

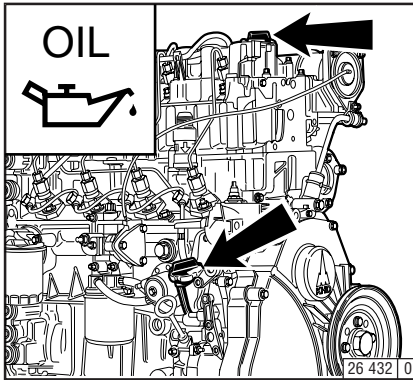

As a rule, engines are delivered empty of oil. Pour lube oil into the oil filler neck (arrow). For oil grade and viscosity, see 4.1.

##### 3.1.1.1 Initial Engine Oil Fill-Up for B/FM1011F Series

- Fill oil into the oil sump up to the „max.“ mark on the engine dip stick (for oil top-up quantity see 9.1).
- Start the engine and allow to run at a low idling speed for approx. 2 mins.
- Switch off the engine.
- Check the oil level, if necessary, top up oil to the „max.“ mark.

##### 3.1.1.2 Initial Engine Oil Fill-up for B/FM 1011F Series

- Fill oil into the oil sump up to the „min.“ mark on the engine dip stick.
- In addition, top up the oil quantity of the supply hoses and of the external oil cooler (according to manufacturer's details).
- Allow the engine to run warm until the thermostat opens (at approx. 95°C).
- Allow the engine to run for approx. 2 mins.
- Switch off the engine.
- Check the oil level, and if necessary, top up oil to the „max.“ mark.

If the person operating the engine does not run up the engine until the thermostat opens, the oil level may lie above the „max.“ mark on the engine dip stick when delivered. The level can then only be assessed after the engine has been run up.

## 3.1 Commissioning

### 3.1.1.3 Initial Engine Oil Fill-Up for B/FM 1011F Genset Engine

- Fill oil into the oil sump up to the “max.” mark on the engine dip stick (for oil quantity see 9.1).
- Start up the engine and allow to run at a lower idling speed for approx. 2 mins.
- Switch off the engine.
- Check the oil level and fill up with oil up to the upper „max.“ mark.

### 3.1.2 Filling Oil Bath Air Filter with Engine Oil

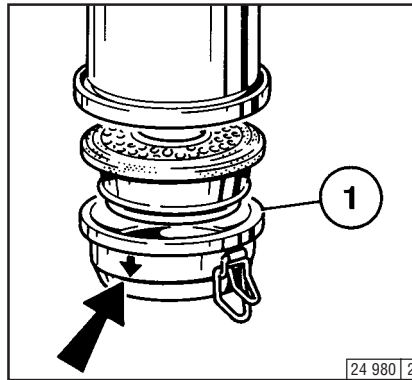

Fill oil cup 1 of the oil bath air cleaner with oil up to the arrow.  
For oil grade and viscosity, see 4.1.



Do not fill the precleaner dust collector (if fitted) with oil.

## Engine Operation

3

### 3.1.3 Adding Fuel

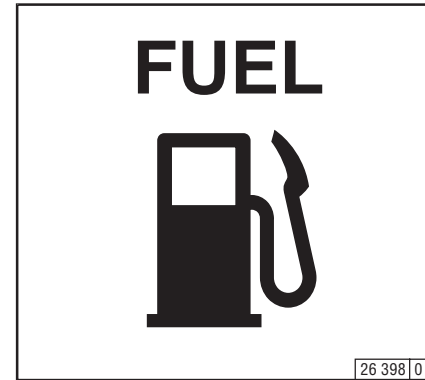

Use only commercial-grade diesel fuel. For fuel grade, see 4.2. Use summer or winter-grade fuel, depending on the ambient temperature.



Never fill the tank while the engine is running. Keep the filler cap area clean and do not spill fuel.



#### 3.1.4 Other Preparations

- Check battery and cable connections, see 6.7.1
- Transport hooks  
Remove if fitted (see 6.7.3)
- Trial run  
After the engine has been prepared, let it run for about 10 minutes without load.  
  
During and after trial run
  - Check the engine for leaksAfter the engine has been turned off
  - Check the oil level,  
see 6.1.2  
If necessary, top up oil,  
see 3.1.1
  - Retension V-belts, see 6.5
- Breaking in  
During the break-in phase – about 200 operating hours – check the oil level twice a day. After the engine is broken in, checking once a day will be sufficient.

#### 3.1.5 Additional Maintenance Work

When commissioning new and reconditioned engines, the following additional maintenance work must be carried out:

##### After 50-150 OH

- Change lube oil,  
see 6.1.2
- Change oil filter cartridge,  
see 6.1.3
- Change fuel filter cartridge,  
see 6.2.1
- Check V-belts and retension as necessary,  
see 6.5.
- Check the engine for leaks
- Check the engine mount and adjust as necessary, see 9.2

##### After 500 OH

- Check the valve clearance and adjust as necessary, see 6.6.1.



# Engine Operation

## 3.2 Starting

3

### 3.2.1 Electric Starting



Before starting, make sure that nobody is standing in the immediate vicinity of the engine or driven machine.

After repair work:

Check that all guards have been replaced and that all tools have been removed from the engine.

When starting with glow plugs, do not use any other starter substance (e.g. injection with start pilot).

**Caution: If the speed regulator has been removed, the engine must not be tested under any circumstances:**

**Disconnect the battery.**

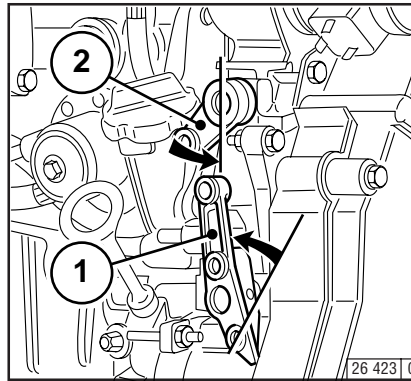

- Where possible, disengage the clutch to separate the engine from any driven parts.
- Move speed control lever 1 into idle position.
- Move cut-out handle 2 into operating position.

### Starting without Cold-Start Aid

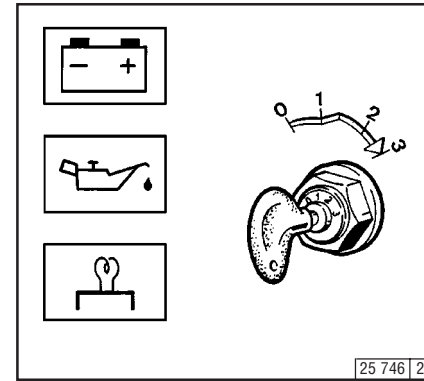

- Insert key.
  - Position 0 = no operating voltage
- Turn key clockwise
  - Position 1 = operating voltage
  - Pilot lights come on
- Push the key in and turn it further clockwise against spring pressure
  - Position 2 = no function
  - Position 3 = start
- Release key as soon as engine fires
  - Pilot lights go out

Do not actuate the starter for more than 20 seconds. If the engine does not catch, wait a minute then try again.

If the engine does not catch after two attempts, refer to the Diagnosis Chart (see 7.1).

## 3.2 Starting

# Engine Operation

3

### with Cold-Start Aid – Glow Plug

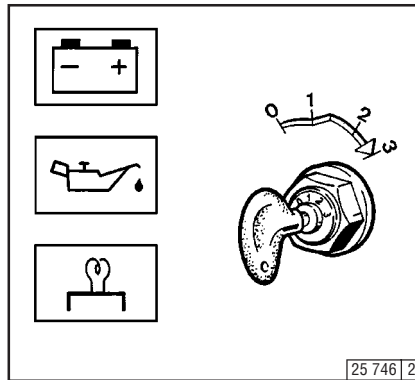

- Insert key.
  - Position 0 = no operating voltage
- Turn key clockwise
  - Position 1 = operating voltage
  - Pilot lights come on
- Push key in and turn further clockwise against spring pressure
  - Position 2 = Preheat, hold for approx. 1 minute.
  - Preheat lamp comes on
  - Position 3 = Start
- Release key as soon as engine fires
  - Pilot lights go out

### with Cold-Start Aid – Ether Starting System

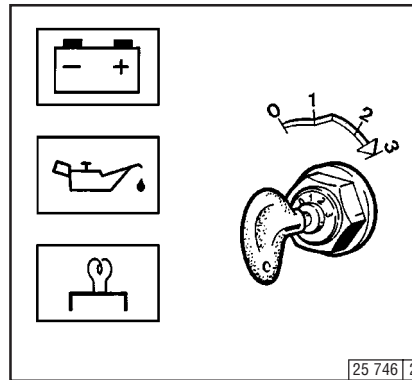

- Insert key
  - Position 0 = no operating voltage
- Turn key clockwise
  - Position 1 = operating voltage
  - Pilot lights come on
- Push key in and turn further clockwise against spring pressure
  - Position 2 = no function
  - Position 3 = start
- Release key as soon as engine fires
  - Pilot lights go out

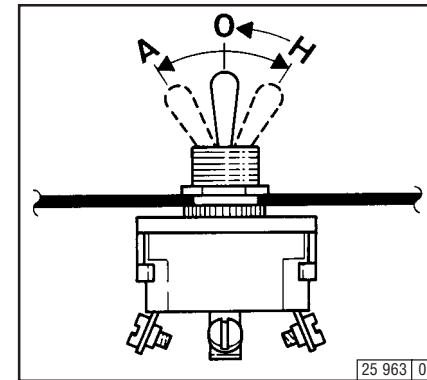

- Starting fluid is injected automatically in switch position **A**, as long as the starter is operated.
- To assist acceleration at lower temperatures and to avoid white fumes, briefly hold the arctic switch in switch position **H**.



The switch must not be moved to position **H** when the engine is switched off and the ignition is switched on.

# Engine Operation

## 3.3 Monitoring Systems

3

### 3.3.1 Engine Oil Pressure Oil Pressure Pilot Light

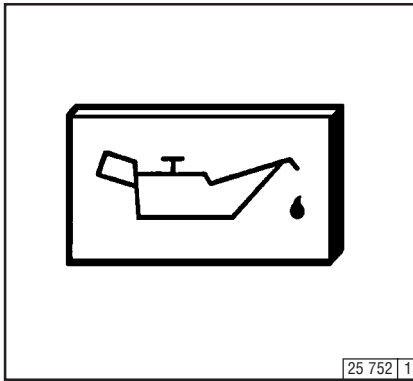

- The oil pressure pilot light comes on with operating voltage on and engine off.
- The oil pressure pilot light should go out when the engine is running.

### Oil Pressure Indicator

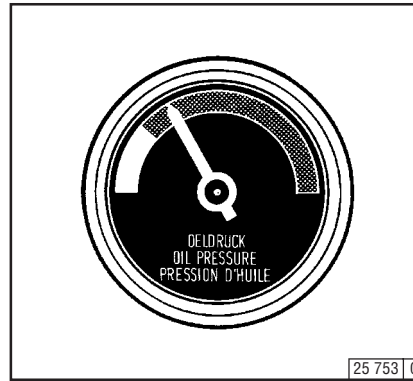

- The pointer must remain in the green sector over the entire range.

### Oil Pressure Gauge

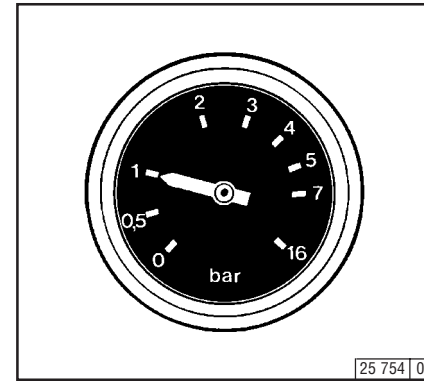

- The pointer must indicate the minimum oil pressure (see 9.1).

## 3.3 Monitoring Systems

# Engine Operation

3

### 3.3.2 Coolant Temperature Engine Temperature Gauge

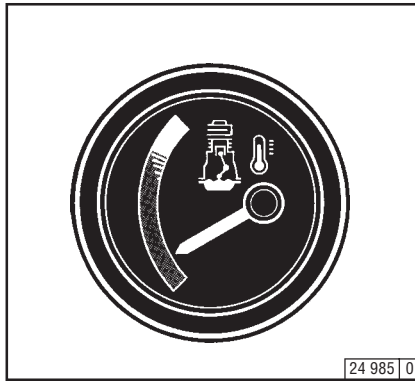

- The engine temperature gauge pointer should remain in the green sector most of the time. It should rarely enter the yellow-green sector. If the pointer enters the orange sector, the engine is overheating. Turn off and establish the cause from the Diagnosis Chart (see 7.1).

# Engine Operation

## 3.4 Stopping

3

### 3.4.1 Mechanical Shutdown

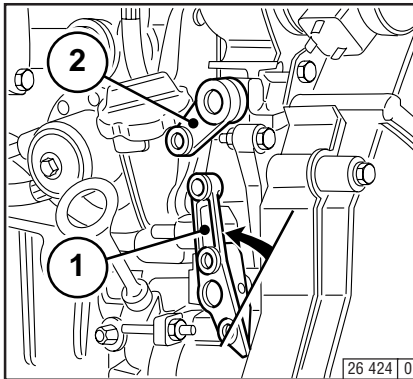

- Move speed control lever 1 to low idle.
- Operate shutdown lever 2 until the engine comes to a stop. The charge pilot light and the oil pressure pilot light will come on when the engine stops.
- Turn key counterclockwise (to position 0) and remove. The pilot lights will go out.

### 3.4.2 Electrical Shutdown (Ignition Key)

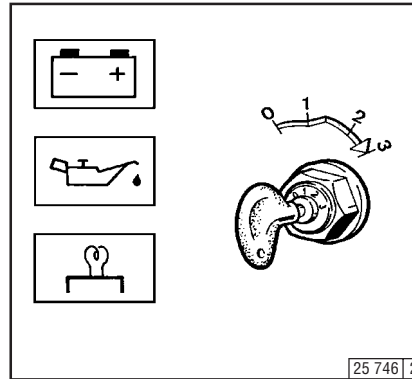

- Turn key counterclockwise (to position 0) and remove. The pilot lights will go out.

If possible, do not suddenly switch off the engine when under full load.

## 3.5 Operating Conditions

## Engine Operation

3

### 3.5.1 Winter Operation

- Lube Oil Viscosity
  - Select the oil viscosity (SAE grade) according to the ambient temperature when the engine is started, see 4.1.2.
  - Increase oil change frequency when operating below  $-10\text{ }^{\circ}\text{C}$ , see 6.1.1.
- Diesel Fuel
  - Use winter-grade diesel fuel for operation below  $0\text{ }^{\circ}\text{C}$ , see 4.2.2.
- Additional Maintenance Work
  - Drain the sludge from the fuel tank once a week. (Unscrew the sludge drain plug)
  - If necessary, allow the oil in the oil bath air cleaner and the engine oil to settle at the ambient temperature.
  - Below  $-20\text{ }^{\circ}\text{C}$ , after removing the starter if necessary, smear the ring gear on the fly wheel via the pinion bore from time to time with cold-resistant grease. (e.g. Bosch grease FT 1 V 31).
- Cold-Start Aid
  - At temperatures near or below freezing point, use glow plugs if necessary, see 3.2.1.  
This not only lowers the starting limit temperature, but provides easier starting at temperatures normally not requiring a start-aid.

- Battery
  - Efficient cold starting requires a healthy battery, see 6.7.1.
  - The starting limit temperatures can be lowered by  $4\text{--}5\text{ }^{\circ}\text{C}$  by heating the battery up to about  $+20\text{ }^{\circ}\text{C}$ . (To do so, remove the battery and store in a warm place).

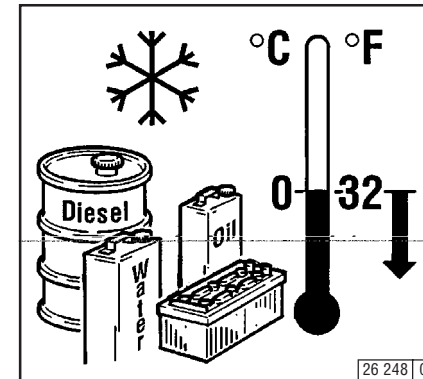



### 3

#### 3.5.2 High Ambient Temperatures, High Altitude

- As the altitude and ambient temperature rise, the density of air tends to decrease, which affects the maximum power output of the engine, the exhaust gas quality and, in extreme cases, the starting behavior. Under transient conditions, the engine can be used at altitudes up to 1000 m and temperatures up to 30 °C. If the engine is to operate under more severe conditions (at higher altitudes or temperatures), it will be necessary to reduce the injected fuel quantity and thus, engine power.
- If you have any doubts about engine operation under these or similar conditions, ask your engine or equipment supplier whether the engine has been derated in the interests of reliability, service life and exhaust gas quality (smoke). Otherwise contact DEUTZ SERVICE.

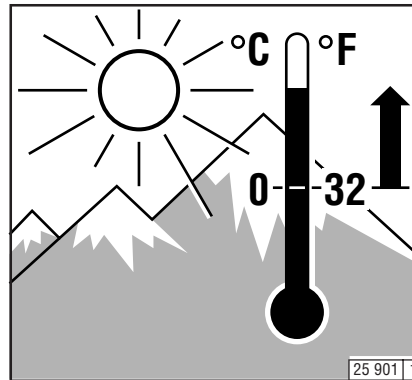

- 4.1 Lube Oil**
- 4.2 Fuel**
- 4.3 Coolant**

# Operating Media

## 4.1 Lube Oil

### 4

#### 4.1.1 Quality Grade

Lube oils are differentiated by **Deutz** according to their performance and quality class. Oils of other, comparable specifications can be used.

Approved oils:			
<b>Deutz</b>	DQC I	DQC II	DQC III
<b>ACEA</b>	E2-96	E3/96/E5-02	E4-99
<b>API</b>	CF/CF-4	CH-4/CG-4	-
<b>DHD</b>	-	DHD-1	-

The precise assignment of the admissible oil qualities to the engines is indicated in chapter 6.1.1.  
If in doubt, contact your service representative.

#### 4.1.2 Viscosity

Generally, multi-grade oils shall be used. In closed heated rooms at temperatures  $>5^{\circ}\text{C}$ , also single-grade oils can be used.

As the viscosity of lube oil is dependent on temperature, the choice of SAE grade should be governed by the ambient temperature prevailing at the engine operating site.

Optimum operating behaviour will be attained if you take the accompanying oil viscosity diagram as a guide.

Should the temperature fall temporarily below the limits of the SAE grade selected, cold starting may be affected but the engine will not be damaged.

In order to keep wear to a minimum, do not exceed application limits for extended periods of time.

Synthetic lube oils feature an improved temperature and oxidation stability.

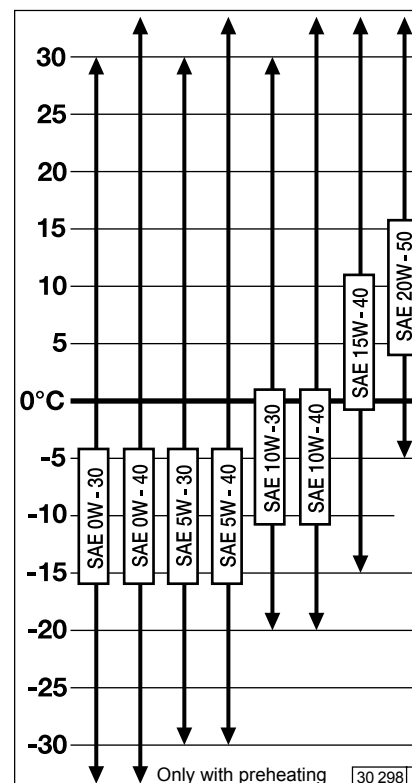

# Operating Media

## 4.2 Fuel

### 4

#### 4.2.1 Quality Grade

Use commercially available diesel fuel with less than 0.5% sulphur content. If the sulfur content is higher than 0.5%, oil change intervals should be reduced (see 6.1.1).

The following fuel specifications/standards are approved:  
(refer to TR 0199-3002)

- **Diesel fuel**
  - DIN EN 590
  - BS 2869: A1 and A2  
(with A2, take note of the sulfur content!)
  - ASTM D 975-88; 1-D and 2-D
  - NATO Code F-54 and F-75
  - ISO 8217 DMX
  - ISO 8217 DMA
- **Light heating oil**  
according to DIN 51603  
ASTM D 396; 1 and 2  
BS 2869 Class D
- **Jet fuel**
  - F34/F35/F44 (kerosene)
  - F54 (equivalent to diesel fuel according to DIN EN 590)
  - XF 63 (equivalent to F34+F35 with additives)
- **Bio diesel fuel**  
- according to DIN 51606- FAME

© 2002

Exhaust emission values which may be determined in the cause of type approval tests always refer to the reference fuel prescribed by the authorities for the type approval test.

#### 4.2.2 Winter-Grade Fuel

Waxing may occur at low temperatures, clogging the fuel system and reducing engine efficiency. If the ambient temperature is less than 0 °C, winter-grade fuel (suitable down to -20 °C) should be used. This fuel is usually available from filling stations well in advance of the cold months.

- At temperatures below -20°C, kerosene should be added to the diesel fuel. The relevant percentages are given in the diagram at the right
- Special diesel fuels can be used for climatic zones down to - 44 °C.

If summer-grade diesel fuel must be used at temperatures below 0°C, up to 60% kerosene can be added (see diagram).

In most cases, adequate resistance to cold can be obtained by adding a flow improver (additive). Please contact your **Deutz** partner.

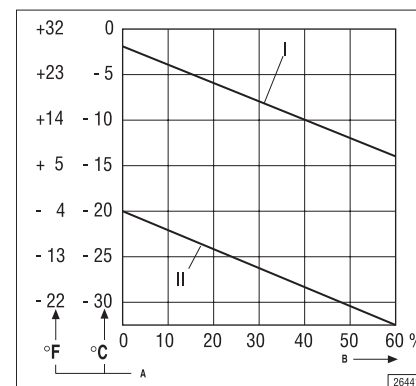

#### Legend:

I	Summer diesel fuel
II	Winter diesel fuel
A	Outside temperature
B	Percentage of kerosene to be added



Diesel fuels must never be mixed with petrol (normal and super grade petrol)!



Mix in tank only. Fill with the appropriate amount of kerosene first, then add the diesel fuel.



- 5.1 Maintenance Schedule**
- 5.2 Maintenance Chart**
- 5.3 Maintenance Work Completed**

# Routine Maintenance

## 5.1 Maintenance Schedule

5

once after 2) 50-150	Operating Hours (OP) every 1)								check			see Section
	every 10 OH or daily	125	250	500	750	1000	2000	3000	clean			
									change			
									Operation			
●									●		Oil level in engine / separate container 9)	6.1.2/3.1.4
●									●		Engine leaks	
	●								●		Oil bath- and dry type air cleaners 3) 4) 5)	6.4
		●							●		Battery and cable connectors	6.7.1
		●	●	●		●	●		●		Cooling system (depending on engine use 3)	6.3.1
●				●7)		●6)			●		Engine oil (depending on engine use) 4) 6)	6.1.1
●				●7)		●6)			●		Oil filter cartridge (depending on oil change interval) 4) 6)	6.1.3
●						●			●		Fuel filter cartridge	6.2.1
				●2)		●			●		Valve clearance (adjust if necessary)	6.6.1
●									●		Engine mounts (retighten if necessary)	9.2
●				●					●		V-belts (retension if necessary)	6.5
									●		Toothed belts 8) 10)	
								●	●		Injection valves	
						●			●		Fuel pump / strainer 5)	6.2.2
						●			●		Fuel leakage line (change defective lines) 11)	6.2.3

The specified engine maintenance times are maximum values. Depending on the operating environment, shorter maintenance intervals may be required. Please observe the operating instructions of the equipment manufacturer.

- 1) recommended maximum
- 2) once when commissioning new and reconditioned engines
- 3) clean if needed
- 4) Oil quality API-CF-4, CG-4, CH-4 or ACEA-E1-3/96 and E4-98
- 5) change if required
- 6) for oil change intervals, naturally aspirated engines, see Section 6.1.1
- 7) for oil change intervals, turbocharged engines, see Section 6.1.1
- 8) without toothed belt ventilation renew after 3000 running hours, after 5 years at the latest if running hours are not reached: in both cases together with idler pulley with toothed belt ventilation renew after 4500 running hours, after 5 years at the latest if running hours are not reached: in both cases together with idler pulley
- 9) during run-in period, check 2 x daily
- 10) retensioning of toothed belts is not permitted
- 11) Change at the latest after 2 years .

## 5.2 Maintenance Chart

## Routine Maintenance

5

The maintenance chart shown here is supplied as a self-adhesive label with each engine. It should be affixed where it can be seen clearly on the engine or driven equipment.

Check that this is the case.

If necessary, ask your engine or equipment supplier for a fresh supply of labels.

Routine work should be carried out according to the schedule in 5.1.

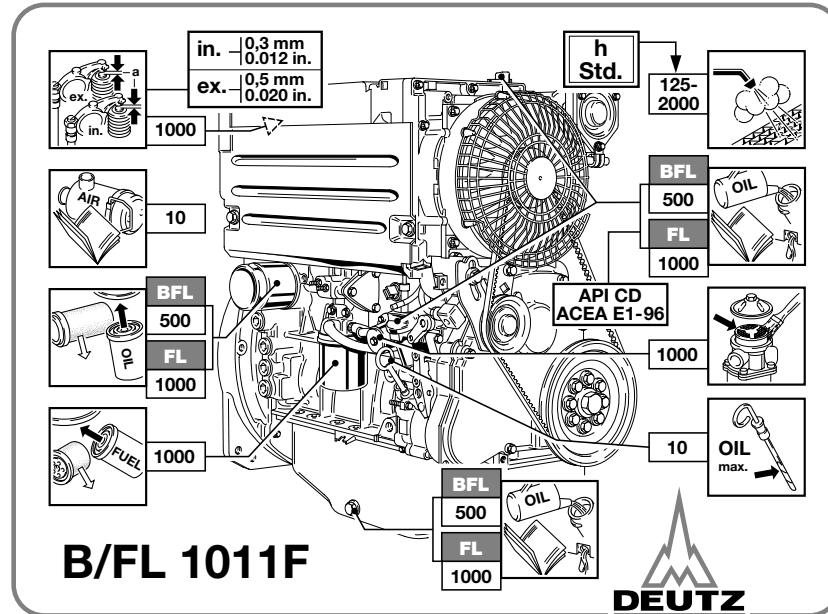

0297 7279



Stop the engine before carrying out any maintenance work.



# Routine Maintenance

## 5.2 Maintenance Chart

5

The maintenance chart shown here is supplied as a self-adhesive label with each engine. It should be affixed where it can be seen clearly on the engine or driven equipment.

Check that this is the case.

If necessary, ask your engine or equipment supplier for a fresh supply of labels.

Routine work should be carried out according to the schedule in 5.1.

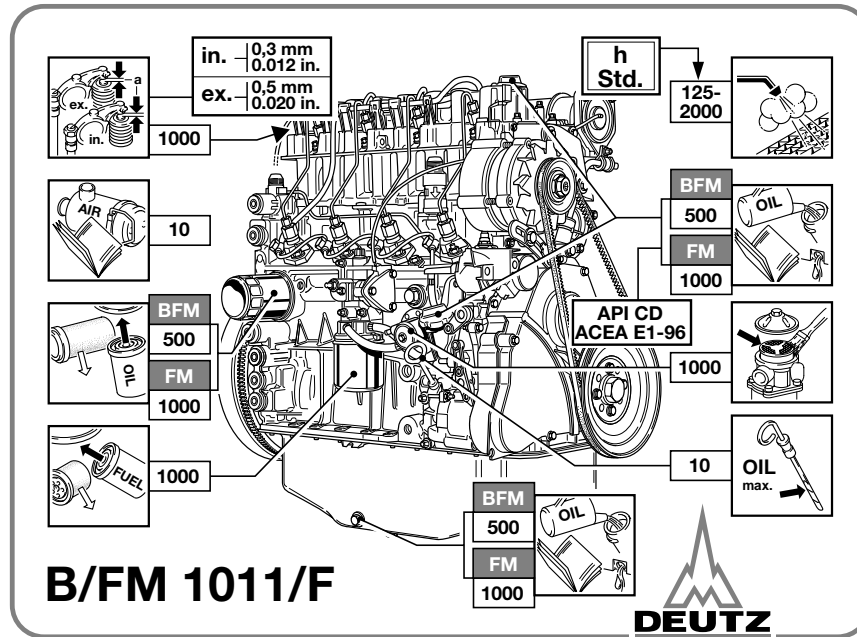

0297 7281 [2]



Stop the engine before carrying out any maintenance work.

## 5.3 Completed Maintenance Jobs

## Routine Maintenance

Hours	Date	Signature / Stamp	Hours	Date	Signature / Stamp
50-150*			-		
125			250		
375			500		
625			750		
875			1000		
1125			1250		
1375			1500		
1625			1750		
1875			2000		
2115			2250		
2375			2500		
2625			2750		

\* Commissioning new and overhauled engines  
 The maintenance jobs duly completed can be recorded in the above table.

**5**

1  
2  
3  
4  
5  
6  
7  
8  
9  
10

# Routine Maintenance

## 5.3 Completed Maintenance Jobs

5

Hours.	Date	Signaure / Stamp	Hours	Date	Signaure / Stamp
2875			3000		
3125			3250		
3375			3500		
3625			3750		
3875			4000		
4125			4250		
4375			4500		
4625			4750		
4875			5000		
5125			5250		
5375			5500		
5625			5750		

The maintenance jobs duly completed can be recorded in the above table.

## 5.3 Completed Maintenance Jobs

## Routine Maintenance

5

Hours	Date	Signature / Stamp	Hours	Date	Signature / Stamp
5875			6000		
6125			6250		
6375			6500		
6625			6750		
6875			7000		
7125			7250		
7375			7500		
7625			7750		
7825			8000		
8125			8250		
8375			8500		
8625			8750		

The maintenance jobs duly completed can be recorded in the above table.



- 6.1 Lubrication System**
  - 6.2 Fuel System**
  - 6.3 Cooling System**
  - 6.4 Combustion Air System**
  - 6.5 Belt Drives**
  - 6.6 Adjustments**
  - 6.7 Accessories**
- Service and Maintenance**

# Service and Maintenance

## 6.1 Lubrication System

6

### 6.1.1 Oil Change Intervals

- The oil change intervals are dependent on the engine application and the quality of the lube oil.
- If the engine runs fewer hours during the year than stated in the table, the oil should be changed at least once a year.
- The table refers to the following conditions:
  - For diesel fuel: sulfur content max. 0.5% by weight.
  - Continuous ambient temperatures down to -10 °C (+14 °F).
- If the sulfur content is > 0.5 to 1% or the continuous ambient temperature below -10 °C (+14 °F), the intervals between oil changes should be halved.

- In the case of fuels containing more than 1% sulfur, contact your service representative.

Installed engines			Lube oil intervals in OH		Lube oil intervals in OH	
			Naturally aspirated engines		Turbocharged engines	
Lube oil quality	API classification		CC 1)	CD/CE 1)	CD/CE/CF-4	—
	CCMC classification		D4	D5 2) (SHPD) 3)	D4	D5 2) (SHPD) 3)
<b>Normal oil usage, e.g.:</b>			250	500	250	500
Road vehicles, cranes, construction machinery, ships, electrical units, pumps, rail-run vehicles						
<b>Heavy-duty oil usage, e.g.:</b>			125	250	125	250
Combine harvesters, emergency pumps, underground equipment, sweeping machines, winter operation equipment, emergency power generating units						
Vehicle engines			Lube oil intervals in km		Lube oil intervals in km	
			Naturally aspirated engines		Turbocharged engines	
Lube oil quality	API classification		CC 1)	CD/CE 1)	CD/CE/CF-4	—
	CCMC classification		D4	D5 2) (SHPD) 3)	D4	D5 2) (SHPD) 3)
Service group	Annual kilometrage km	average speed approx. km/h				
I	to 30 000	20	5 000	10 000	5 000	10 000
II	more than 30 000 to 100 000	40	10 000	20 000	10 000	20 000
III	more than 100 000	60	15 000	30 000	15 000	30 000

Change the oil with the engine off but still warm (lube oil temperature approx. 80 °C).

<sup>1)</sup> Lube oils having both a C- and an S classification (e.g. CD / SE) can be used. Oils with only a C classification (e.g. CE) generally perform very well in diesel engines and are to be preferred.

<sup>2)</sup> D5 grade oil with sulfate ash content > 1.8% by mass.

<sup>3)</sup> SHPD lube oils can be used.

These are the equivalent of D5 grade.

## 6.1 Lubrication System

## Service and Maintenance

6

### 6.1.2 Checking Oil Level / Changing Engine Oil

#### 6.1.2.1 Checking Oil Level

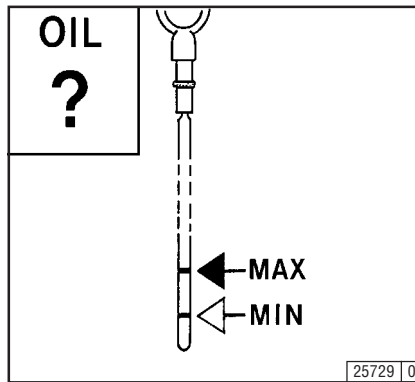

- Check the oil level with the engine switched off.
- Ensure that the engine or vehicle is in a level position.
- Remove the oil dipstick.
- Wipe the dipstick with a non-fibrous, clean cloth
- Insert it to the stop and remove again.
- Check the oil level, and if necessary, top up to the **"MAX"** mark. If the oil level is only just above the **"MIN"** mark, more oil must be added.

The oil level must not drop below the **"MIN"** mark

#### 6.1.2.2 Changing the Engine Oil

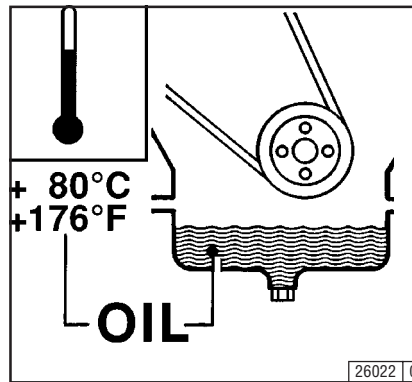

- Allow the engine to warm up.
- Ensure that the engine or vehicle is on a level position.
  - Lube oil temperature approx. 80 °C.
- Turn the engine off.

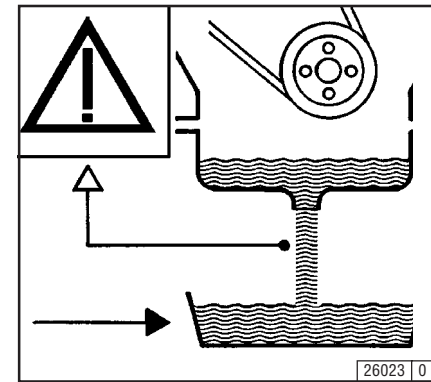

- Place oil tray under the engine.
- Unscrew drain plug.
- Drain oil.
- Fit oil drain plug with the new gasket and tighten firmly (for torque see 9.2).
- Pour in lube oil
  - For grade / viscosity, see 4.1.
  - For quantity see 9.1.
- Check the oil level, see 6.1.2.1



! Be careful when draining hot oil - danger of scalds!  
Do not let used oil run into the soil but catch it in a container ready for proper disposal!



# Service and Maintenance

## 6.1 Lubrication System

6

### 6.1.3 Changing Oil Filter

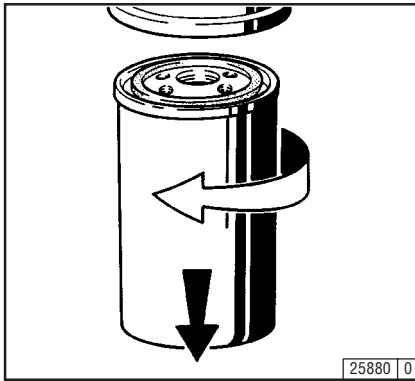

- Undo the filter cartridge using a commercial tool and spin off.
- Catch any dripping oil.

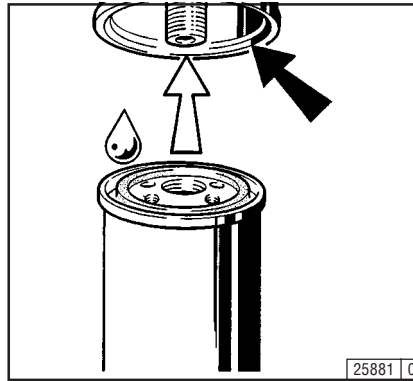

- Clean any dirt from the filter carrier rim.
- Lightly oil the rubber gasket of the new oil filter cartridge.
- Screw in the new cartridge finger tight against the gasket.

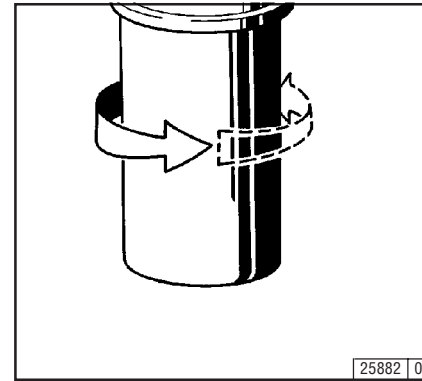

- Tighten the oil filter cartridge with another half-turn.
- Check oil level, see 6.1.2.
- Check oil pressure, see 3.3.1.
- Check cartridge seal for leaks.



Beware of burns from hot oil.

## 6.2 Fuel System

## Service and Maintenance

6

### 6.2.1 Changing Fuel Filter

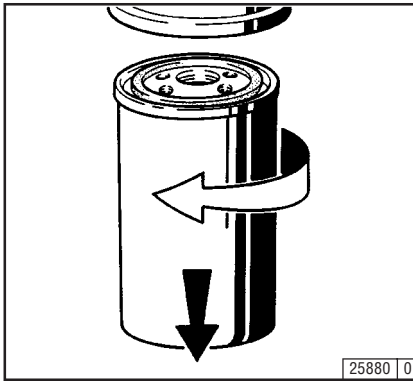

- Close fuel stopcock.
- Undo fuel filter cartridge with commercial tool and spin off.
- Catch any fuel.

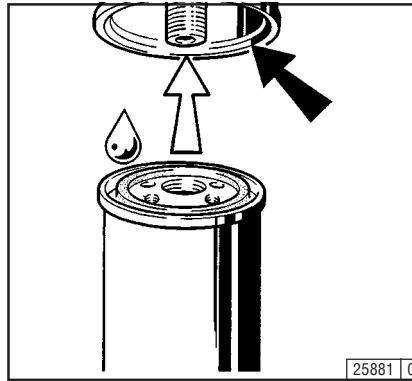

- Clean any dirt from the filter cartridge with a final half-turn.
- Apply light film of oil or diesel fuel to the rubber gasket of the new fuel filter cartridge.
- Screw in the new cartridge finger tight against

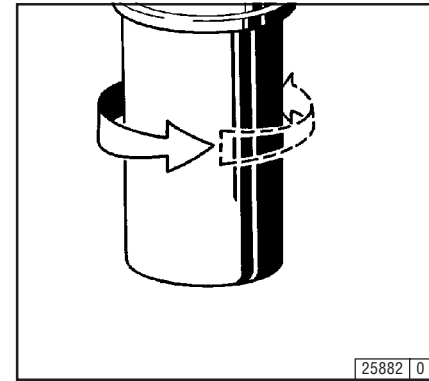

- the gasket.
- Tighten the fuel filter cartridge with a final half-turn.
- Open fuel stopcock.
- Check for leaks.



Keep naked flames away when working on the fuel system. Do not

The fuel system does not need to be bled.

# Service and Maintenance

## 6.2 Fuel System

6

### 6.2.2 Fuel Pump Cleaning the Strainer

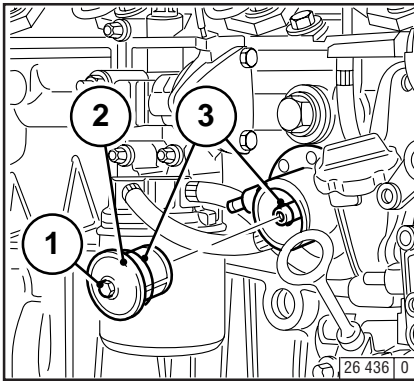

- Close the fuel shut-off valve.
- Loosen and unscrew the hexagonal nut 1.
- Remove the fuel strainer cover 2 (cover and strainer, one unit)
- Clean the fuel strainer with diesel fuel. Replace if necessary.
- Place seals 3 in position.

- Mount the fuel strainer cover 2.
- Tighten the hexagonal screw 1.
- Check for leaks.



Keep naked flames away when working on the fuel system.  
Do not smoke!

### 6.2.3 Change Fuel Leakage Line

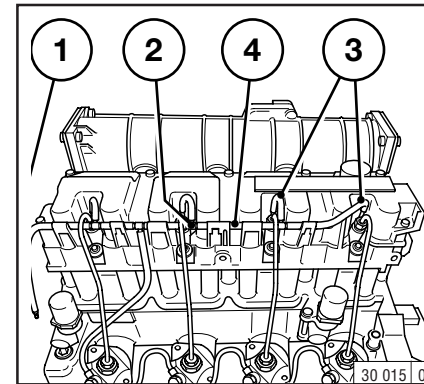

- Close the fuel shutoff valve.
- Disconnect rubber hoses 3 from the injection valves.
- Disconnect rubber hose 1 from fuel tank.
- Disconnect rubber hoses 4, 3 and 1 from unions 2 and dispose of in an environmentally friendly manner.
- Connect new rubber hoses 4, 3 and 1 to unions 2.
- Connect rubber hoses 3 to injection valves.
- Connect rubber hose 1 to fuel tank.
- Open fuel shutoff valve.
- Check for leaks after start-up.

## 6.3 Cooling System

# Service and Maintenance

6

### 6.3.1 Cleaning Intervals

- The amount of contamination in the cooling system depends on the engine application.
- Spilled oil or fuel on the engine increases the risk of contamination. Be especially careful if the engine is used in dusty environments.
- Serious contamination can occur, for example:
  - on construction sites where there is a high level of air-borne dust.
  - in harvesting application where there are high concentrations of chaff and chopped straw in the vicinity of the machine.
- Because applications vary, cleaning intervals have to be determined from case to case. The cleaning intervals given in the table on the right can be used as a guide.
- Clean the engine as described in 6.8.1.

Inspection and cleaning intervals Recommended OH	Engine application
2000	Ships, Electrical units in enclosed areas, pumps
1000	Vehicles on reinforced highways
500	Tractors, fork-lift trucks, mobile electrical units
250	Vehicles on construction sites and on roads with loose surfaces, construction machinery, compressors, mining equipment
125	Agricultural machinery, tractors used for harvesting purposes

#### 6.4.1 Cleaning Intervals

- The amount of dirt in the air cleaner depends on the amount of dust in the air and the size of the air cleaner used. If a high level of dust is anticipated, a cyclone-type precleaner can be fitted to the air cleaner.
- Cleaning intervals will have to be determined from case to case.
- Air cleaner servicing is needed when:
  - **Service indicator**  
the red signal 1 is fully visible when the engine is off.
  - **Service switch**  
the yellow pilot light comes on when the engine is running.
- After carrying out service work, reset the signal by pressing the button on the service indicator.

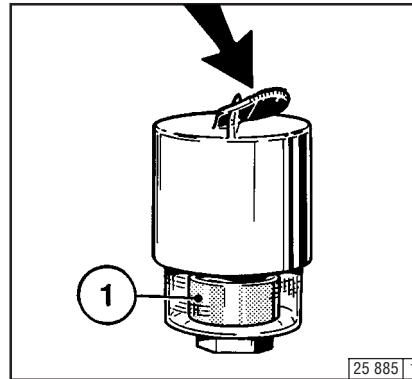

## 6.4 Combustion Air Filter

# Service and Maintenance

6

### 6.4.2 Emptying Cyclone Type Precleaner

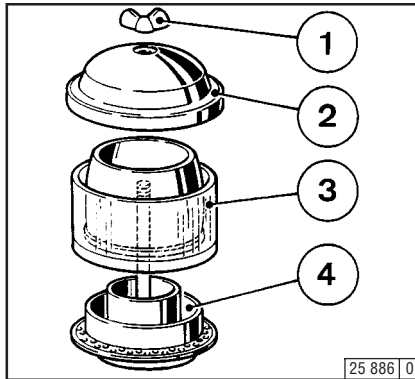

- Undo wing nut 1 and remove cover 2.
- Remove collector bowl 3 from lower section 4 and empty. Clean leaves, straw and other foreign matter from lower section of pre-cleaner.
- Reposition collector bowl 3 onto lower section 4, fasten cover 2 in place by tightening wing nut 1.

Never fill collector bowl with oil. Replace collector bowl if damaged.

### 6.4.3 Cleaning Oil Bath Air Cleaner

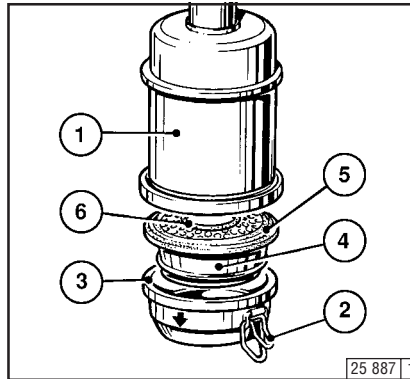

- Turn engine off and wait about 10 minutes for the oil to drain from filter housing 1.
- Release snap clips 2 and remove oil cup 3 together with filter element 4. If necessary prise element out with a screwdriver, taking care not to damage the rubber gasket 5.
- Remove dirty oil and sludge. Clean oil cup.
- Clean filter element 4 in diesel fuel and allow to drip-dry.

- Clean filter housing 1 if very dirty.
- Inspect and replace rubber gasket 5 and 6 if necessary.
- Fill oil cup with engine oil up to the mark (arrow) (for viscosity, see 4.1.2).
- Refit oil cup and element to filter housing and secure with snap clips.



Never clean air cleaner with gasoline. Dispose of cold oil in accordance with environmental regulations!

# Service and Maintenance

## 6.4 Combustion Air Cleaner

6

### 6.4.4 Dry Type Air Cleaner Dust Discharge Valve

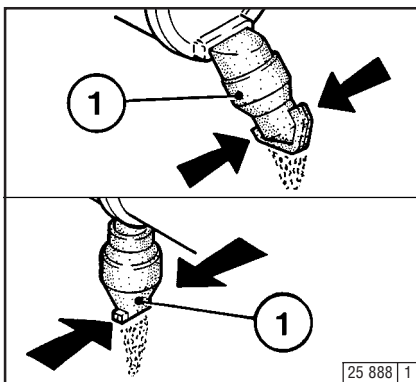

- Empty dust discharge valve 1 by pressing apart lips of discharge slot as indicated by arrows.
- Clean discharge slot from time to time.
- Remove any caked dirt by pressing together the upper section of the valve.

### Filter Cartridge

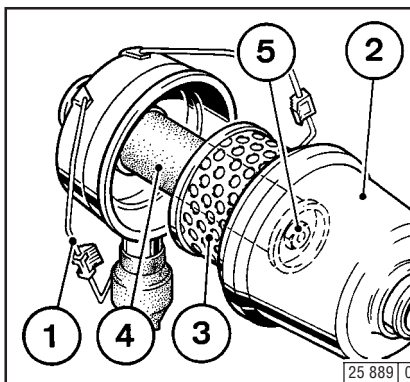

- Undo clip fasteners 1.
- Take off hood 2 and remove cartridge 3.
- Clean cartridge (replace at least once a year)
- Clean cartridge 3.  
Blow out from inside out with dry compressed air (max. 5 bar), (or in difficult cases, tap out, taking care not to damage the cartridge, or wash according to manufacturer's instructions).
- Through regular removal and replacement, the gaskets on the filter cartridge can become damaged. Check paper filter (light showing through) and gaskets for damage. Replace if necessary.

- After five cleaner services or after two years at the latest, replace safety cartridge 4 (never clean).  
To do so:
  - Undo hex. nut 5 and remove cartridge 4.
  - Install new cartridge, insert and tighten hex nut.
- Install cartridge 3, replace hood 2 and do up clip fasteners 1.



Never clean filter cartridge with gasoline or hot fluids.

## 6.5 Belt Drives

# Service and Maintenance

6

### 6.5.1 Checking V-Belts

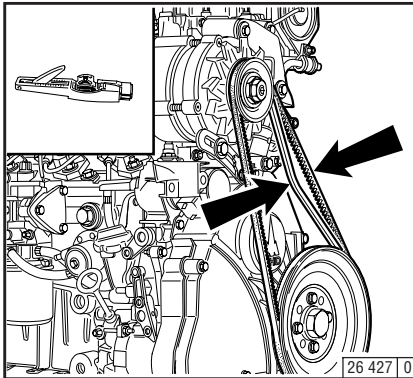

- Inspect entire V-belt for damage.
- Replace damaged V-belts.
- After installing new belts, run engine for 15 minutes, then check belt tension.
- To check the tension of the V-belt, use a tension gauge (see 9.3).
  - Place indicator arm 1 into gauge.
  - Position gauge on V-belt 2, midway between the pulleys, with flange 3 on bottom of gauge against the edge of belt.
  - Push slowly on the black pad 4 at right angles to belt 2 until the spring is heard or felt to trigger.

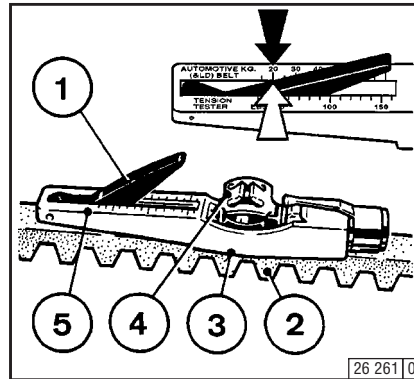

- Carefully remove the gauge without altering the position of the indicator arm 1.
- Read off the value where the black indicator arm 1 intersects scale 5 (arrow). For settings, see 9.1.
- If necessary, retension belt and measure again.



Check tension and change belts only with the engine off. Refit belt guard, if provided.

When new V-belts are fitted, check the belt tension after ca. 15 minutes running time.



#### 6.5.2 Tensioning Alternator Belts

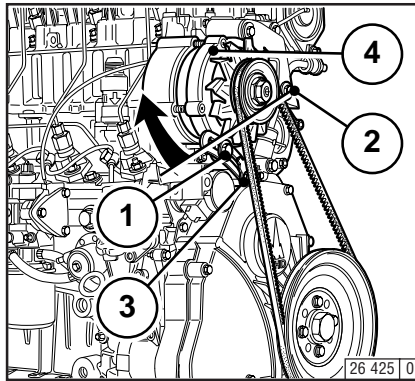

- Slacken off bolts 1, 2 and 3.
- Adjust alternator 4 in direction of arrow by turning bolt 3 until correct belt tension is achieved.
- Retighten bolts 1, 2 and 3.

#### 6.5.3 Changing Alternator Belts

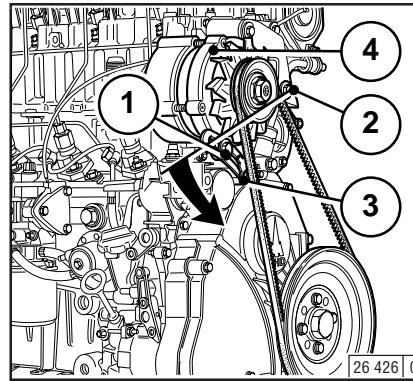

- Slacken off bolts 1, 2 and 3.
- Adjust alternator 4 in direction of arrow by turning bolt 3.
- Remove and replace belt.
- Adjust alternator 4 against the direction of the arrow by turning bolt 3, until correct belt tension is achieved.
- Retighten bolts 1, 2 and 3.



Check, tension and change belts only with the engine off. Refit belt guard, if provided.

# Service and Maintenance

---

**6**

#### 6.6.1 Checking / Adjusting Valve Clearances

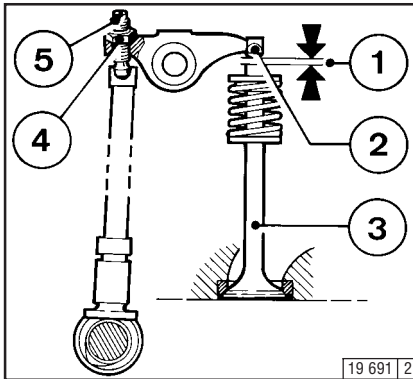

- Remove the cylinder head cover.
- Position crankshaft as per schematic 6.6.1.1.
- Before adjusting valve clearance, allow engine to cool down for at least 30 minutes. The oil temperature should be below 80 °C.
- Check valve clearance 1 between rocker arm / tappet contact face 2 and valve stem 3 with feeler gauge 6 (there should be only slight resistance when feeler blade is inserted).  
For permissible valve clearance, see 9.1.

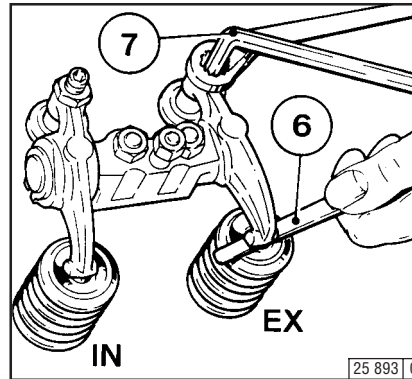

- Adjust valve clearance if necessary:
  - Release locknut 4.
  - Use allen key 7 to turn setscrew 5 so that the correct clearance is attained after locknut 4 has been tightened.
- Check and adjust valve clearance on all remaining cylinders.
- Replace cylinder head cover (use new gasket if needed).

## 6.6 Adjustments

# Service and Maintenance

6

### 6.6.1.1 Valve Clearance Adjustments Schematic

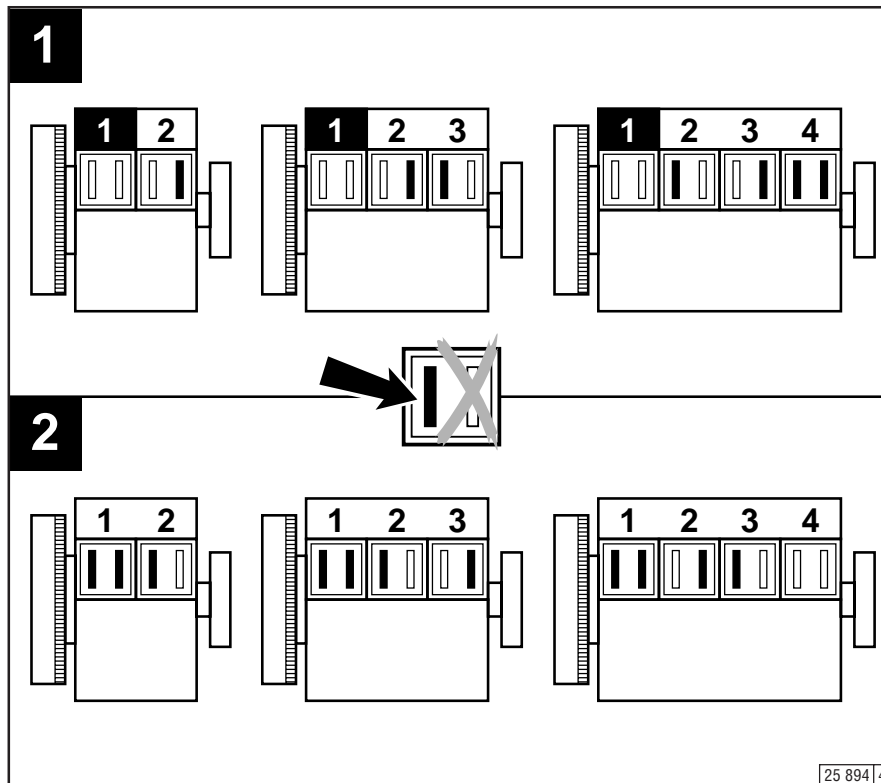

#### ● Crankshaft Position 1:

Turn crankshaft until both valves in cylinder 1 overlap (exhaust valve about to close, inlet valve about to open). Adjust clearance of valves marked in black on schematic. Mark respective rocker arm with chalk to show that adjustment has been done.

#### ● Crankshaft Position 2:

Turn crankshaft one full revolution (360°). Adjust clearance of valves **marked in black** on schematic.

# Service and Maintenance

## 6.7 Accessories

6

### 6.7.1 Battery

#### 6.7.1.1 Checking Battery and Cable Connectors

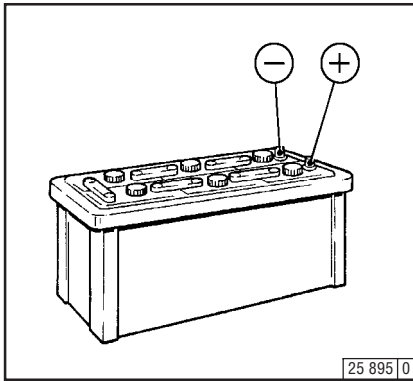

- Keep battery clean and dry.
- Undo dirty clamps.
- Clean terminal posts (+ and -) and clamps of the battery, and grease with acid-free and acid-resistant grease.
- When reassembling, ensure that clamps make good contact. Do up clamp bolts finger tight.

#### 6.7.1.2 Checking Electrolyte Level

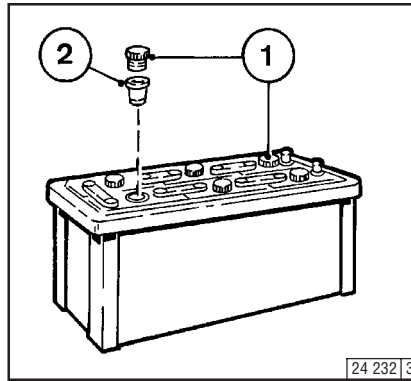

- Remove caps 1.
- If testers 2 are used, the electrolyte should come up to their base.
- If testers are not used, the electrolyte level should be 10-15 mm above the top of the plates.
- If necessary, top up with distilled water.
- Replace caps.

#### 6.7.1.3 Checking Electrolyte Density

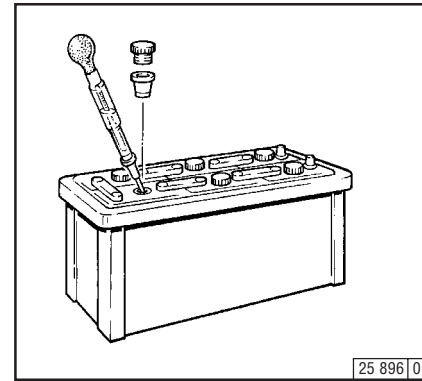

- Measure the electrolyte density of individual cells with a commercial hydrometer.

The hydrometer reading (see table on following page) indicates the state of charge. During measurement, the temperature of the electrolyte should preferably be 20 °C.

Electrolyte density				
in kg/l		in ° Bé (Baumégrad)*		State of Charge
Normal	Tropics	Normal	Tropics	
1.28	1.23	32	27	Fully charged
1.20	1.12	24	16	Half charged, recharge
1.12	1.08	16	11	Discharged, recharge immediately

\* Measurement of electrolyte density in ° Bé (Baumé-grad) is out of date and rarely used today.



The gases emitted by the battery are explosive! Keep sparks and naked flames away from the battery. Do not allow battery acid to come into contact with skin or clothing.

Wear protective goggles. Do not rest tools on the battery.

### 6.7.2 Three-Phase Alternator

Notes on the three-phase system:

- Never disconnect the cables between battery, alternator and regulator while the engine is running.
- If, however, it is necessary to start and operate the engine without the battery, disconnect the regulator from the alternator before starting.
- Be sure not to confuse the battery terminals.
- Replace defective bulb of the charge pilot lamp immediately.
- When washing the engine, cover up the alternator and regulator.
- The habit of touching a lead against the frame to check whether it is live must under no circumstances be used with three-phase electrical systems.
- In case of electric welding, connect the ground terminal on the welder directly to the piece being welded.

### 6.7.3 Lifting Tackle

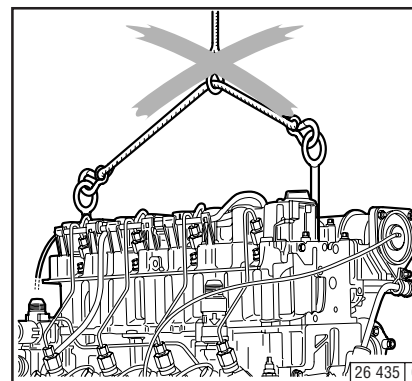
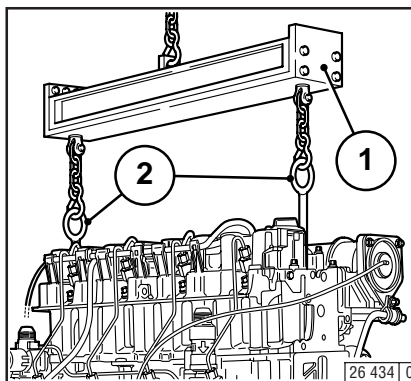

- Always use proper lifting tackle 1 when transporting the engine.
- After transportation and before commissioning of the engine:  
Remove attachment eyes 2.



Use only the correct lifting tackle.

## 6.7 Accessories

## Service and Maintenance

6

### 6.7.4 Ether Starting System

#### 6.7.4.1 Changing the Fluid Container

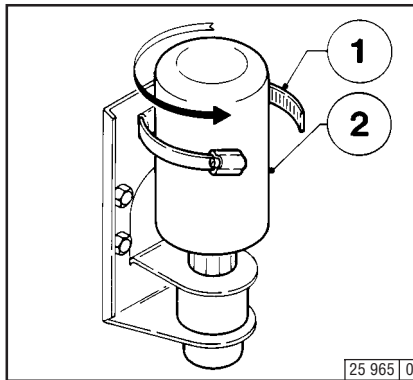

- Before removing the container, clean the container support and the top of the solenoid valve.
- Loosen the bracket 1.
- Unscrew the fluid container 2.
- Empty or replace the depressurized fluid container.

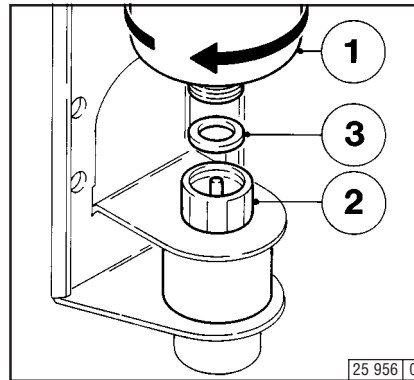

- Place the container 1 on the solenoid valve 2 and tighten by hand.
- When mounting, ensure that gasket 3 is seated correctly.
- Pull in the brackets.
- Check for leaks.



Before commissioning, leave the fluid container of the ether starting system in position for 15 minutes. Check for leaks. The starting fluid is inflammable. Ensure that the container is not damaged. Prevent foreign substances from entering the container. The fluid container must not be stored at temperatures above 50 °C.



### 6.8.1 Engine Cleaning

#### Preparation

- Switch off the engine.
- Remove engine covers and cooling air hood. Replace them after cleaning and before the test run.
- Cover electrical / electronic components / connections (eg. generator, starter, governor, solenoid).

#### Using compressed air

- Blow air through the engine, taking particular care not to damage the cooler and cooling fins (begin to blow through air from the exhaust side).  
Remove the dirt which has blown into the interior space.

#### Using cold-cleaning compound

- Spray the engine with the commercial cold-cleaning compound and allow to react for approx. 10 mins.
- Spray clean the engine with a strong water jet, repeat if necessary.
- Allow the engine to run up so that the remaining water evaporates.

#### Using high pressure device

- Clean the engine with a steam jet (max. spray pressure of 60 bar, max. steam temperature of 90°C).
- Allow the engine to run up so that the remaining water evaporates.



Clean the engine only when the engine is switched off.

## 7.1 Diagnosis Chart

- Faults are often caused by maloperation of the engine or failure to service the engine.
- In the event of a fault, always check whether the operating and servicing regulations have been adhered to.
- A corresponding fault table can be found on the adjacent page.
- If you cannot ascertain the cause of a fault or cannot rectify the fault, please contact DEUTZ SERVICE.

## 7.1 Diagnosis Chart

## Faults, Causes and Remedies

7

Fault										Remedy		
Engine fails or is difficult to start										Check	P	
Engine starts but runs unevenly or stalls										Adjust	E	
Engine overheats. Temperature monitor gives warning										Replace	W	
Engine gives poor performance										Clean	R	
Engine not firing on all cylinders										Top up	A	
Engine has little or no oil pressure										Lower level	S	
Engine oil consumption excessive												
Engine smokes – blue												
– white												
– black												
<b>Cause</b>										<b>Section</b>		
●										Not declutched (where possible)	Operation	P
●								●		Below starting limit temperature		P
		●						●		Oil level too low		A
		●	●				●	●		Oil level too high		P
							●	●	●	Excessive inclination of engine		S
●							●			Incorrect lube oil SAE class or quality	Operating media	W
●	●		●						●	Fuel quality not as per operating manual		W
		●	●						●	Air cleaner clogged / turbocharger defective	Combustion air	P / W
		●	●						●	Air cleaner service switch / indicator defective		P / W
									●	LDA* defective		P
			●						●	Charge air line leaking		P
		●								Oil cooler panels clogged	Cooling system	P / R
		●								Cooling fan defective, split or loose V-belt		P / W
		●								Cooling air temperature rise / heating short circuit		P
		●								Resistance in cooling system too great / through-flow quantity too small		P
●										Battery defective or discharged	Electrics	P / A

\* LDA = Aneroid device

# Faults, Causes and Remedies

## 7.1 Diagnosis Chart

7

Fault										Remedy		
										Engine fails or is difficult to start	Check	P
										Engine starts but runs unevenly or stalls	Adjust	E
										Engine overheats. Temperature monitor gives warning	Replace	W
										Engine gives poor performance	Clean	R
										Engine not firing on all cylinders	Top up	A
										Engine has little or no oil pressure	Lower level	S
										Engine oil consumption excessive		
										Engine smokes – blue		
										– white		
										– black		
										<b>Cause</b>	<b>Section</b>	
●										Electric cable connections to starter electrical system loose or oxidized	Electrics	P
●										Starter defect or pinion does not engage		P
●										Solenoid defective (release switch)		P
●	●		●					●	●	Incorrect valve clearance	Engine	E
	●		●	●						Leaking injection line		P
●	●	●	●	●				●	●	Injection valve defective		P / W

**8.1 Preservation**

# Engine Preservation

## 8

If the engine is to remain idle for an extended period of time, it is necessary to take protective measures to prevent rusting. The preservative measures described here will protect the engine for up to 6 months. The procedure will have to be reversed before the engine is recommissioned.

- Anti-corrosion oils to specification:
  - MIL-L-21260B
  - TL 9150-037/2
  - Nato Code C 640 / 642
- Anti-corrosion media for exterior protection only to specification:
  - Nato Code C 632
- Recommended cleaning agent to remove preservatives:
  - Petroleum benzine
  - (hazardous materials class A3)

### 8.1.1 Preserving Engine

- Clean engine using high-pressure equipment (or with cold-cleansing agent in emergency).
- Run engine until warm, then turn off.
- Drain engine oil (see 6.1.2) and fill with anti-corrosion oil.
- If necessary, clean oil bath cleaner (see 6.4.3) and fill with anti-corrosion oil.
- Drain fuel tank.
- Make up a mixture of 90% diesel fuel and 10% anti-corrosion oil, and refill fuel tank.
- Allow engine to run for approx. 10 mins.
- Switch off engine.
- Turn engine over manually several times to preserve cylinders and combustion chamber.
- Remove V-belts and store in wrapped condition.
- Spray grooves on V-belt pulleys with anti-corrosion spray.
- Close intake ports and exhaust ports.

## 8.1 Preservation

### 8.1.2 Removing Engine Preservatives

- Remove anti-corrosion agent from grooves in V-belt pulleys.
- Install V-belt, retension after brief operation if necessary, see 6.5.
- Remove covers from intake port and exhaust port.
- Commission engine, see also 5.1, note 2.

- 9.1 Engine Specifications and Settings**
- 9.2 Torque Wrench Settings**
- 9.3 Tools**



# Technical Specifications

## 9.1 Engine Specifications and Settings

9

### Model

Numbers of cylinders	
Cylinder arrangement	
Bore	[mm]
Stroke	[mm]
Total displacement	[cm <sup>3</sup> ]
Compression ratio	[ε]
Working cycle	
Combustion system	
Direction of rotation	
Weight incl. integrated cooling system as per DIN 70020-A (without starter, with alternator)	ca.[kg]
Engine power	[kW (PS)]
Speed	[1/min]
Lubrication	
SAE oil	
Max. oil temperature in oil sump	[°C]
Min. oil pressure in warm condition, oil temperature 110 °C at: 900/min (low idling speed)	[bar]
1800 /min	[bar]
max. 3300 /min, *max. 3000 /min	[bar]
Oil change quantity (oil sump) ca.	[ltr.]
Oil change quantity with filter (Standard 0.5 ltr.) ca.	[ltr.]
Valve clearance with cold engine	[mm]
(Engine cooling time at least 30 Min.: Oil temperature below 80°C)	[mm]
Start of delivery	[°crank angle b TDC]
Injector opening pressure: vehicle/genset engine	[bar]
Firing order of the engine	
V-Belt tension: Pretension / Retension (after the engine has been running under load for 15 mins):	[N]

F2L 1011F	F3L 1011F	F4L 1011F	F4L 1011FL*
2	3	4	4
vertical in line			
91			
105	105	105	112
1366	2049	2732	2912
18,5			
4-stroke diesel engine			
naturally aspirated engine with direct injection			
counter clockwise			
167	208	249	250
1)			
1)			
pressure lubrication			
20 W 20			
130			
1,4 <sup>3)</sup>			
2,2 <sup>3)</sup>			
3 <sup>3)</sup>			
6 <sup>2)</sup>	5,5 <sup>2)</sup>	10 <sup>2)</sup>	10 <sup>2)</sup>
6,5 <sup>2)</sup>	6 <sup>2)</sup>	10,5 <sup>2)</sup>	10,5 <sup>2)</sup>
inlet 0.3			
exhaust 0.5			
1)			
210 / 250 <sup>8)</sup>			
1 - 2	1 - 2 - 3	1 - 3 - 4 - 2	1 - 3 - 4 - 2
450 / 350 ±20			

<sup>1)</sup> Engine power, speed, start of delivery are stamped on engine rating plate, see also 2.1.

<sup>2)</sup> Ca. value can vary depending on model. **The upper oil dipstick marking should always be taken as authoritative.**

<sup>3)</sup> Values for engines without engine oil heating.

# Technical Specifications

## 9.1 Engine Specifications and Settings

### Model

Number of cylinders	
Cylinder arrangement	
Bore	[mm]
Stroke	[mm]
Total displacement	[cm³]
Compression ratio	[ε]
Working cycle / Combustion system	
Direction of rotation	
Weight without cooling system	[kg]
Weight without starter, with alternator as per DIN 70020-A ca.	[kg]
Engine power	[kW (PS)]
Speed	[1/min]
Lubrication	
SAE oil	
Max. oil temperature in the oil sump	[°C]
at: 900/min (low idling speed)	[bar]
1800 /min	[bar]
max. 3000 /min	[bar]
Oil change quantity (oil sump without cooling system) ca.	[ltr.]
Oil change quantity with filter (Standard 0.5 ltr.) ca.	[ltr.]
Valve clearance with cold engine (Engine cooling time at least 30 mins.: oil temperature below 80°C)	[mm]
Injector opening pressure: vehicle/genset engine	[bar]
Start of delivery	[°crank angle b TDC]
Firing order of the engine	
V-Belt tension: Pretension / Retension (after the engine has been running under load for 15 mins):[N]	

BF3L 1011F/L	BF4L 1011F/FT
3	4
vertical in line	
91	
105/112	105
2184	2732
17	
4-stroke diesel with turbocharging and direct injection	
counter clockwise	
Refer to head-office	
233	256
1)	
1)	
pressure lubrication	
20 W 20	
130	
1,4 <sup>3)</sup>	
2,2 <sup>3)</sup>	
3 <sup>3)</sup>	
7,5	10 <sup>2)</sup>
8	10,5 <sup>2)</sup>
inlet 0,3 + 0,1 / exhaust 0,5 + 0,1	
210 / 250 <sup>+8</sup>	
1)	
1 - 2 - 3	1-3-4-2
450 / 350 ±20	

<sup>1)</sup> Engine power, speed, start of delivery are stamped on engine rating plate, see also 2.1.

<sup>2)</sup> Ca. value can vary depending on oil sump and or cooler design (external cooling system). **The upper oil dipstick marking should always be taken as authoritative.**

<sup>3)</sup> Values for engines without engine oil heating.

# Technical Specifications

9

9

## Model

Number of cylinders  
Cylinder arrangement

Bore

Stroke

Total displacement

Compression ratio

Working cycle

Combustion system

Direction of rotation

Weight without cooling system

(without starter, with generator) ca.

Engine power

Speed

Lubrication

SAE oil

Maximum oil temperature in the oil sump

Minimum oil pressure in warm condition, oil temperature 110 °C,

at: 900/min (low idling speed)

1800 /min

max. 3000 /min

## Engine with Thermostat

Oil change quantity without external cooler (see 3.1.1.2)/ without filter approx.

Oil change quantity without external cooler (see 3.1.1.2) + filter replacement

(Standard 0.5 litre) approx.

## Genset engine without Thermostat:

Oil change quantity including cooler (see 3.1.1.3)/ without filter approx.

Oil change quantity including cooler (see 3.1.1.3) + filter replacement

(Standard 0.5 litre) approx.

Valve clearance at cold engine

(Engine cooling time at least 30 mins.: oil temperature below 80°C)

Start delivery

Injector opening pressure: vehicle/genset engine

Firing order of the engine

V-Belt tension: Pretension / Retension(after the engine has been running under load for 15 mins):[N]

	F3M 1011F	F4M 1011F
	3	4
	vertical in line	
[mm]	91	
[mm]	112	112
[cm <sup>3</sup> ]	2184	2912
[e]	18,5	
	4-stroke diesel engine	
	naturally aspirated engine with direct injection	
	counter clockwise	
	Rückfrage Stammhaus	
[kg]	200	242
[kW (PS)]	1)	
[1/min]	1)	
	Druckumlaufschmierung	
	20 W 20	
[°C]	130	
[bar]	1,4 3)	
[bar]	2,2 3)	
[bar]	3 3)	
[ltr.]	5,5 2)	10 2)
[ltr.]	6 2)	10,5 2)
[ltr.]	8,5 2)	13 2)
[ltr.]	9 2)	13,5 2)
[mm]	inlet 0,3 <sup>+</sup> 0,1 / exhaust 0,5 <sup>+</sup> 0,1	
[°crank angle b TDC]	1)	
[bar]	210 / 250 <sup>+8</sup>	
	1 - 2 - 3	1 - 3 - 4 - 2
	450 / 350 ±20	

1) Engine power, speed, start of delivery are stamped on engine rating plate, see also 2.1.

2) Ca. value can vary depending on oil sump and or cooler design (external cooling system). **The upper oil dipstick marking should always be taken as authoritative.**

3) Values for engines without engine oil heating.

# Technical Specifications

## 9.1 Engine Specifications and Settings

9

Model		BF3M 1011 F	BF4M 1011 F
Number of cylinders		3	4
Cylinder arrangement		vertical, in line	
Bore	[mm]	91	
Stroke	[mm]	112	
Total displacement	[cm <sup>3</sup> ]	2184	2912
Compression ratio	[ε]	17	
Working cycle		4-stroke diesel	
Combustion system		turbocharging and direct injection	
Direction of rotation		counter clockwise	
Weight without cooling system (without starter, with generator) ca.	[kg]	226	249
Engine power	[kW (PS)]	1)	
Speed	[1/min]	1)	
Lubrication		pressure lubrication	
SAE oil		20 W 20	
Maximum oil temperature in the oil sump	[°C]	130	
Minimum oil pressure in warm condition, oil temperature 110 °C, at: 900/min (low idling speed)	[bar]	1,4 <sup>3)</sup>	
1800 /min	[bar]	2,2 <sup>3)</sup>	
max. 2800 /min	[bar]	3 <sup>3)</sup>	
<b>Engine with Thermostat</b>			
Oil change quantity without external cooler (see 3.1.1.2)/ without filter approx.	[ltr.]	7,5	10 <sup>2)</sup>
Oil change quantity without external cooler (see 3.1.1.2) + filter replacement (Standard 0.5 litre) approx.	[ltr.]	8	10,5 <sup>2)</sup>
<b>Genset engine without Thermostat:</b>			
Oil change quantity including cooler (see 3.1.1.3)/ without filter approx.	[ltr.]	11	13,5 <sup>2)</sup>
Oil change quantity including cooler (see 3.1.1.3) + filter replacement (Standard 0.5 litre) approx.	[ltr.]	11,5	14 <sup>2)</sup>
Valve clearance at cold engine (Engine cooling time at least 30 mins.: oil temperature below 80°C)	[mm]	inlet 0,3 <sup>+0,1</sup> / exhaust 0,5 <sup>+0,1</sup>	
Start delivery	[°crank angle b TDC]	1)	
Injector opening pressure: vehicle/genset engine	[bar]	210 / 250 <sup>+8</sup>	
Firing order of the engine		1-2-3	1-3-4-2
V-Belt tension: Pretension / Retension (after the engine has been running under load for 15 mins):-[N]		400 / 300 ±20	

<sup>1)</sup> Engine power, speed, start of delivery are stamped on engine rating plate, see also 2.1.

<sup>2)</sup> Ca. value can vary depending on oil sump and or cooler design (external cooling system). **The upper oil dipstick marking should always be taken as authoritative.**

<sup>3)</sup> Values for engines without engine oil heating.

# Technical Specifications

## 9.2 Torque Wrench Settings

9

Location	Preload [Nm]			Torquing Load [Nm]				Total [Nm]	Remarks
	1st Stage	2nd Stage	3rd Stage	1st Stage	2nd Stage	3rd Stage	4th Stage		
Rocker cover								8,5	
Rocker arm set screw								21	
Air intake manifold								21	
Exhaust manifold								40	
Oil drain plug								55	
Injector mounting								21	TORX
Injector line mounting								22	
Oil pan (cast iron)								31	
Oil pan (sheet metal)								21	

## 9.3 Tools

# Technical Specifications

### TORX

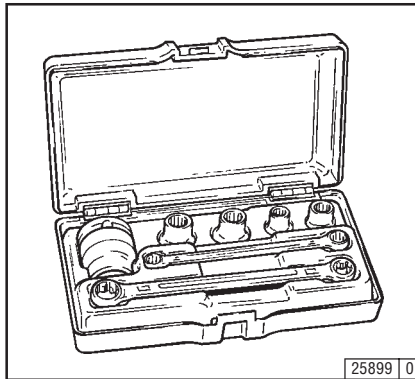

A TORX wrench set (order number 8189) is used with engines in the 1011 series. This system was chosen because of the many advantages it offers:

- Outstanding accessibility to bolts.
- High load transfer when loosening and tightening.
- Almost impossible for socket to slide off or break.

**TORX tools can be ordered from:**  
**COMPANY WILBÄR**  
Postfach 14 05 80  
D-42826 Remscheid

### V-belt Tension Gauge

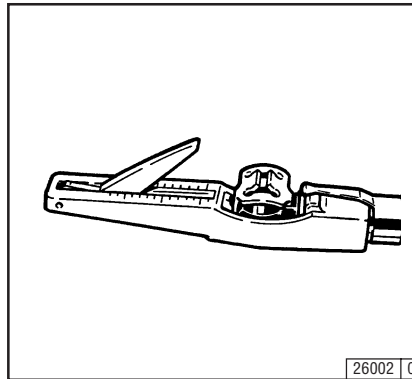

The V-belt tension gauge can be obtained under order number 91 107 from:

**COMPANY WILBÄR**  
Postfach 14 05 80  
D-42826 Remscheid

# Notes

## Warnings to Place on Equipment

### **CALIFORNIA**

#### **Proposition 65 Warning**

**Diesel engine exhaust and some of its constituents are known to the State of California to cause cancer, birth defects, and other reproductive harm.**

## Warning in the Manual

### **CALIFORNIA**

#### **Proposition 65 Warning**

**Diesel engine exhaust and some of its constituents are known to the State of California to cause cancer, birth defects, and other reproductive harm.**

**or**

### **CALIFORNIA**

#### **Proposition 65 Warning**

**Diesel engine exhaust and some of its constituents are known to the State of California to cause cancer, birth defects, and other reproductive harm.**

# Notes

---

## **CALIFORNIA PROPOSITION 65 INFORMATION**

### **TO CALIFORNIA CUSTOMERS AND TO CUSTOMERS SELLING DIESEL ENGINE EQUIPMENT INTO OR FOR USE IN CALIFORNIA.**

Proposition 65, a California law, requires warnings on products which expose individuals in California to chemicals listed under that law, including certain chemicals in diesel engine exhaust.

**Obligations of Manufactures of Diesel-Powered Off-Road Equipment.** The California Superior Court has approved either of the following two methods of compliance with Proposition 65 requirements by manufactures of off-road equipment containing diesel engines. (The court order containing these provisions is attached.)

- 1. On-Equipment Warning.** Place the warning pictured in attachment 1 on all equipment shipped by you into or for sale in California after January 1, 1996. The warning must be in a location where it is easily visible to the operator of the equipment when (s)he is operating the equipment. The warning must be secured to the equipment. If warnings or operating instructions are provided through a digital display, you may use that method of providing warning.
- 2. Operator Manual Warning.** When the operator manual is next revised or by December 31, 1995 whichever is earlier, place the warning in attachment 2 in the operator manual. The warning may be either printed in the manual or on a sticker.

The warning must appear in one of the following locations:

- Inside The front cover
- Inside the back cover
- Outside the front cover
- Outside the back cover
- As the first page of text

Under either alternative, the warning must appear in the same size, print and format as the attachment selected or be of an equally conspicuous size and format. If the warning is provided in an on-screen display, the warning must contain the language in the attachment and must be provided at the time of or in connection with ignition in the same manner as other safety warnings electronically communicated on screen.

**Obligation of Resellers of Diesel Engines.** This letter must accompany any loose diesel engine sold in California. Should you have any questions, please call Deutz Corporation Product Support Department.



# Notes

---

9

## Knowing it's DEUTZ

DEUTZ has always stood for excellence in motor construction, pioneering many developments in the industry. As an independent motor manufacturer, we offer — worldwide — a comprehensive range of diesel and gas motors spanning from 4kW to 7,400kW. Our products are perfectly tailored to meet our customers' individual requirements.

Over 1.4 million DEUTZ motors do their job reliably all over the world. We are determined to preserve the high standard of performance and dependability of our motors, thus keeping our customers satisfied at all times. Therefore we are represented worldwide through a network of highly competent service partners who will meet the needs of our customers, wherever they are.

This is why DEUTZ is not only the name for motors which pack a lot of inventive genius. DEUTZ also means reliable service and comprehensive support to enhance your motor's performance.

This index Sales & Service offers you an overview of the DEUTZ partners in your vicinity, including the products for which they are responsible and the range of services provided. But even when no direct product responsibility is mentioned, your DEUTZ partner will be happy to help you with expert advice.

The Index is constantly updated. Please ask your DEUTZ service partner for the latest edition.

DEUTZ AG — at your service.

Order-No.: 0312 0806

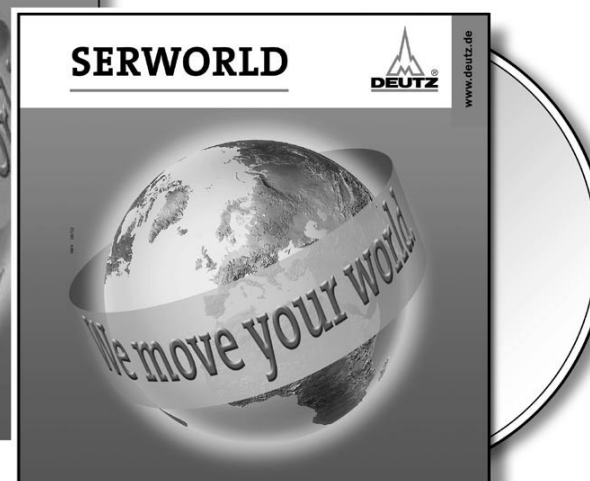
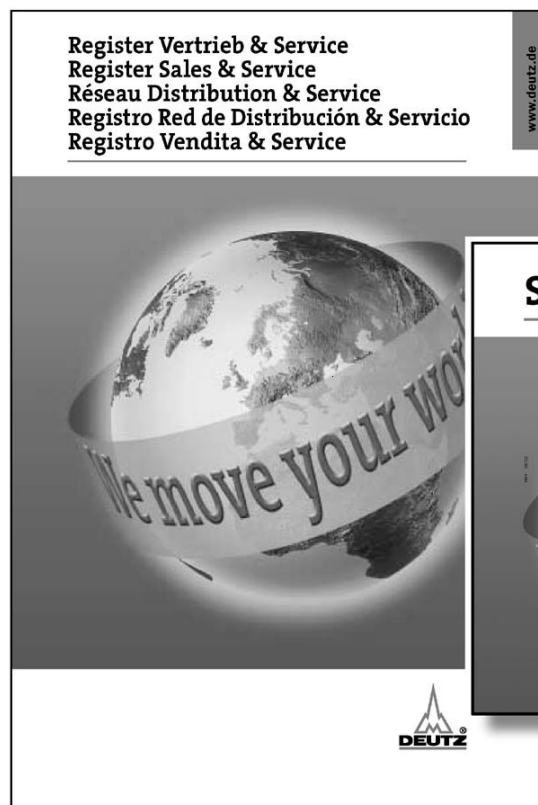

Order-No.: 0312 0807 (CD-ROM)

DEUTZ AG  
 Deutz-Mülheimer Str. 147-149  
 D-51057 Köln

Phone: 0049-221-822-0  
 Telefax: 0049-221-822-5304  
 Telex: 8812-0 khd d  
<http://www.deutz.de>

Obtainable from the local service Partner responsible for you or from: